

ARMY TM 9-6115-729-10
AIR FORCE TO 35C2-3-519-1
NAVAIR 19-50-26
MARINE CORPS TM 07464C-10/1

TECHNICAL MANUAL

**OPERATOR'S MANUAL
FOR
GENERATOR SET, SKID MOUNTED, TACTICAL QUIET
100 kW, 50/60 Hz
MEP-807A
NSN 6115-01-296-1463 (EIC: KP1)**

**GENERATOR SET, TRAILER MOUNTED, TACTICAL QUIET
100 kW, 50/60 Hz
PU-807A
NSN 6115-01-471-7088 (EIC: KPB)**

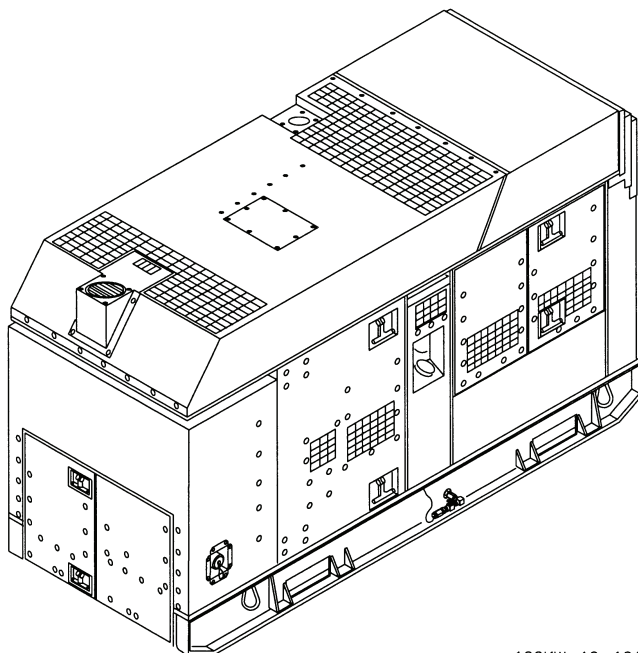

100KW-10-101A

DISTRIBUTION STATEMENT A – Approved for public release; distribution is unlimited.

**HEADQUARTERS, DEPARTMENTS OF THE ARMY,
AIR FORCE, NAVY, AND HEADQUARTERS U.S. MARINE CORPS**

NAVAIR STATEMENT – Published by Direction of Commander, Naval Air Systems Command

**15 JANUARY 2006
PCN 182 074642 00**

WARNING SUMMARY

ICONS

The following icons are sometimes used in conjunction with WARNINGS so that you do not miss important information. They are not meant to be a substitute for reading the WARNINGS, but they give graphic descriptions of dangers.



ELECTRICAL – electrical wire to hand with electricity symbol running through hand shows that shock hazard exists.



RADIATOR – steam in face and body shows that escaping steam and hot water exist.



EAR PROTECTION – headphones over ears shows that noise level will harm ears.



EXPLOSION – flame and burst shows that material may explode if subjected to high temperatures, sources of ignition or high pressure.



COLD – hand in touching cold surface shows that the material is extremely cold and can injure human skin or tissue.



VAPOR – human figure in a cloud shows that vapors, fumes, or exhaust present a danger to life or cause death.



HOT – hand touching hot surface shows that the surface is extremely hot and can burn human skin or tissue.

WARNING SUMMARY – Continued

This section provides a summary of all critical safety information in this manual. It includes a list of all WARNINGS in work package procedures. In some cases, WARNINGS on the same subject that are shown separately below are separate paragraphs under the same WARNING heading in work packages.

Prior to starting any work package procedure, the WARNINGS included in the initial setup and text for that work package must be reviewed and understood.

Also review the MATERIALS/PARTS in the INITIAL SETUP of the work package for hazardous materials used during maintenance of the equipment. Then, refer to the detailed WARNINGS for hazardous materials listed separately in this WARNING SUMMARY.

WARNING

Metal jewelry can conduct electricity and become entangled in generator set components. Remove all metal jewelry when working on generator set. Failure to comply can cause injury or death to personnel.

WARNING

High voltage is produced when this generator set is in operation. Make sure unit is completely shut down and free of any power source before attempting any repair or maintenance on the unit. Failure to comply can cause injury or death to personnel.

WARNING

High voltage is produced when the generator set is in operation. Never attempt to start the generator set unless it is properly grounded. Failure to comply can cause injury or death to personnel.

WARNING

High voltage is produced when the generator set is in operation. Never attempt to connect or disconnect load cables while the generator set is running. Failure to comply can cause injury or death to personnel.

WARNING

DC voltages are present at generator set electrical components even with generator set shut down. Avoid shorting any positive with ground/negative. Failure to comply can cause injury to personnel and damage to equipment.

WARNING

Slave receptacle (NATO connector) is electrically live at all times and is unfused. The Battery Disconnect Switch does not remove power from the slave receptacle. NATO slave receptacle has 24 VDC even when Battery Disconnect Switch is set to OFF. This circuit is only dead when the batteries are fully disconnected. Disconnect the batteries before performing maintenance on the slave receptacle. Failure to comply can cause injury or death to personnel.

WARNING SUMMARY – Continued

WARNING

High voltage power is available when the main contactor is closed. Avoid accidental contact with live components. Ensure load cables are properly connected and the load cable door is shut before closing main contactor. Ensure load is turned off before closing main contactor. Ensure that soldiers working with/on loads connected to the generator set are aware that main contactor is about to be closed before closing main contactor. Failure to observe this warning can result in severe personal injury or death by electrocution.

WARNING

A qualified technician must make the power connections and perform all continuity checks. The power source may be a generator or commercial power. Failure to comply with this warning can result in injury or death to personnel.

WARNING

Do not wear loose clothing when performing checks, services and maintenance. Failure to comply can cause injury or death to personnel.

WARNING

Diesel fuel is flammable and toxic to eyes, skin, and respiratory tract. Skin and eye protection are required when working in contact with diesel fuel. Avoid repeated or prolonged contact. Provide adequate ventilation. Operators are to wash exposed skin and change chemical soaked clothing promptly if exposed to fuel. Failure to comply can cause injury or death to personnel.

WARNING

Fuels used in the generator set are flammable. When filling the fuel tank, maintain metal-to-metal contact between filler nozzle and fuel tank opening to eliminate static electrical discharge. Failure to comply can result in flames and possible explosion and can cause injury or death to personnel and damage to the generator set.

WARNING

Fuels used in the generator set are flammable. Do not smoke or use open flames when performing maintenance. Failure to comply can result in flames and possible explosion and can cause injury or death to personnel and damage to the generator set.

WARNING

Hot engine surfaces from the engine and generator circuitry are possible sources of ignition. When hot refueling with DF-1, DF-2, JP5 or JP8, avoid fuel splash and fuel spill. Do not smoke or use open flame when performing refueling. Remember PMCS is still required. Failure to comply can result in flames and possible explosion and can cause injury or death to personnel and damage to the generator set.

WARNING SUMMARY – Continued

WARNING

If necessary to move a generator set that has been operating in parallel with another generator set, shut down all generator sets prior to removing load cables or ground. Failure to comply can cause injury or death to personnel by electrocution.

WARNING

Before making any connections for parallel operation or moving a generator set that has been operating in parallel, ensure there is no input to the load board and the generator sets are shut down. Failure to comply can cause injury or death to personnel by electrocution.

WARNING

Cooling system operates at high temperature and pressure. Contact with high pressure steam and/or liquids can result in burns and scalding. Shut down generator set, and allow system to cool before performing checks, services and maintenance. Failure to comply can cause injury or death to personnel.

WARNING

Cooling system operates at high temperature and pressure. When performing DURING PMCS, wear gloves and additional protective clothing and goggles as required. Contact with high pressure steam and/or liquids can result in burns and scalding.

WARNING

In extreme cold weather, skin can stick to metal. Avoid contacting metal items with bare skin in extreme cold weather. Failure to comply can cause injury or death to personnel.

WARNING

Operating the generator set exposes personnel to a high noise level. Hearing protection must be worn when operating or working near the generator set when the generator set is running. Failure to comply can cause hearing damage to personnel.

WARNING

When running, generator set engine has hot metal surfaces that will burn flesh on contact. Shut down generator set, and allow engine to cool before checks, services and maintenance. Wear gloves and additional protective clothing as required. Failure to comply can cause injury or death to personnel.

WARNING SUMMARY – Continued

WARNING

When running, generator set engine has hot metal surfaces that will burn flesh on contact. When performing DURING PMCS, wear gloves and additional protective clothing as required. Failure to comply can cause injury or death to personnel.

WARNING

Exhaust discharge contains deadly gases including carbon monoxide. Do not operate generator set in an enclosed area unless exhaust discharge is properly vented outside. Failure to comply can cause injury or death to personnel.

WARNING

Hot exhaust gases can ignite flammable materials. Allow room for safe discharge of hot gases and sparks. Failure to comply can cause injury or death to personnel.

WARNING

Exhaust system can get very hot. Shut down generator set, and allow system to cool before performing checks, services and maintenance. Failure to comply can cause severe burns and injury to personnel.

WARNING

Exhaust system can get very hot. When performing DURING PMCS, wear gloves and additional protective clothing as required. Failure to comply can cause severe burns and injury to personnel.

WARNING

When running, winterization heater has hot metal surfaces that will burn flesh on contact. Shut down generator set and allow heater to cool before performing maintenance. Wear gloves and additional protective clothing as required. Failure to comply can cause injury or death to personnel.

WARNING

Top housing panels can get very hot. Allow panels to cool down before performing maintenance. Failure to comply can result in severe burns to personnel.

WARNING

Top housing panels can get very hot. When performing DURING PMCS, wear gloves and additional protective clothing as required. Failure to comply can result in severe burns to personnel.

WARNING SUMMARY – Continued

WARNING

Eye protection is required when working with compressed air. Compressed air can propel particles at high velocity and injure eyes. Do not exceed 15 psi pressure when using compressed air. Failure to comply could cause serious injury to personnel.

WARNING

Cleaning compound is toxic. Avoid prolonged breathing of vapors. Use only in a well-ventilated area. Failure to comply can cause serious injury to personnel.

WARNING

When disconnecting or removing batteries, disconnect the negative lead that connects directly to the grounding stud first. Disconnect the negative end of the interconnection cable next. When installing batteries, reverse the connection sequence. Failure to comply can cause serious injury to personnel.

WARNING

Batteries give off a flammable gas. Do not smoke or use open flame when performing maintenance. Failure to comply can cause injury or death to personnel and equipment damage due to flames and explosion.

WARNING

This manual describes physical and chemical processes that may require the use of chemicals, solvents, paints, or other commercially available material. Users of the manual should obtain the material safety data sheets (Occupational Safety and Health Act (OSHA) Form 20 or equivalent) from the manufacturers or suppliers of materials to be used. Users must be completely familiar with manufacturer/supplier information and adhere to their procedures, recommendations, warnings, and cautions for safe use, handling, storage, and disposal of these materials.

FOR FIRST AID, REFER TO FM 4-25.11.

INSERT LATEST UPDATED PAGES/WORK PACKAGES. DESTROY SUPERSEDED DATA.

LIST OF EFFECTIVE PAGES/WORK PACKAGES

NOTE: The portion of text affected by the updates is indicated by a vertical line in the outer margins of the page. Updates to illustrations are indicated by miniature pointing hands and/or vertical lines. Updates to wiring diagrams are indicated by shaded boxes.

Dates of issue for original and updated pages/work packages are:

Original .. 0 .. 15 January 2006

TOTAL NUMBER OF PAGES FOR FRONT AND REAR MATTER IS 36 AND TOTAL NUMBER OF WORK PACKAGES IS 23, CONSISTING OF THE FOLLOWING:

Page/WP No.	*Change No.	Page/WP No.	*Change No.
Title.....	0	Chp 3 Index.....	0
Title Blank.....	0	WP 0008 00 (2 pgs).....	0
a - f	0	WP 0009 00 (7 pgs).....	0
A	0	WP 0009 00-8 Blank.....	0
B Blank	0	WP 0010 00 (8 pgs).....	0
Title Block Page.....	0	Chp 4 Title Page	0
ii - iv	0	Chp 4 Index.....	0
Chp 1 Title Page.....	0	WP 0011 00 (2 pgs).....	0
Chp 1 Index	0	WP 0012 00 (16 pgs).....	0
WP 0001 00 (5 pgs)	0	WP 0013 00 (3 pgs).....	0
WP 0001 00-6 Blank	0	WP 0013 00 Blank	0
WP 0002 00 (11 pgs)	0	WP 0014 00 (2 pgs).....	0
WP 0002 00-12 Blank	0	WP 0015 00 (2 pgs).....	0
WP 0003 00 (8 pgs)	0	WP 0016 00 (4 pgs).....	0
WP 0004 00 (1 pg)	0	WP 0017 00 (2 pgs).....	0
WP 0004 00-2 Blank	0	WP 0018 00 (1 pgs).....	0
Chp 2 Title Page.....	0	WP 0018 00- Blank.....	0
Chp 2 Index	0	Chp 5 Title Page	0
WP 0005 00 (18 pgs)	0	Chp 5 Index.....	0
WP 0006 00 (39 pgs)	0	WP 0019 00 (2 pgs).....	0
WP 0006 00-40 Blank	0	WP 0020 00 (9 pgs).....	0
WP 0007 00 (6 pgs)	0	WP 0020 00-10 Blank.....	0
Chp 3 Title Page.....	0	WP 0021 00 (2 pgs).....	0
		WP 0022 00 (2 pgs).....	0
		WP 0023 00 (3 pgs).....	0
		WP 0023 00-4 Blank.....	0
		Glossary-1 – Glossary-2 ..	0
		Index-1 – Index-9.....	0
		Index 10 Blank	

* Zero in this column indicates an original page or work package.

TM 9-6115-729-10

HEADQUARTERS,
DEPARTMENTS OF THE ARMY, AIR FORCE, NAVY, AND
HEADQUARTERS U.S. MARINE CORPS
WASHINGTON, D.C., 15 January 2006

TECHNICAL MANUAL

OPERATOR'S MANUAL
FOR
GENERATOR SET, SKID MOUNTED, TACTICAL QUIET
100 kW, 50/60 Hz
MEP-807A
NSN 6115-01-296-1463 (EIC: KP1)

GENERATOR SET, TRAILER MOUNTED, TACTICAL QUIET
100 kW, 50/60 Hz
PU-807A
NSN 6115-01-471-7088 (EIC: KPB)

REPORTING ERRORS AND RECOMMENDING IMPROVEMENTS

You can help improve this manual. If you find any mistakes, or if you know of a way to improve the procedures, please let us know. We'd prefer that you submit your recommended changes electronically, either by e-mail <AMSEL-LC-LEO-PUBS-CHG@mail1.monmouth.army.mil> or online <<http://edm.Monmouth.army.mil/pubs/2028.html>>. Alternately, you may mail or fax your letter, DA Form 2028 (Recommended Changes to Publications and Blank Forms) or DA Form 2028-2 located in back of this manual to: Commander, U.S. Army Communications-Electronics Life Cycle Management Command (C-E LCMC) and Fort Monmouth, ATTN: AMSEL-LC-LEO-E-ED, Fort Monmouth, New Jersey 07703-5006. The fax number is 732-532-3421, DSN 992-3421.

For Air Force, use AFTO Form 22 in accordance with TO 00-5-1 and mail directly to Commander, WR-ALC/LEET, Robins AFB, GA, 31098. You may also e-mail your form to <<http://wralc.tilta.afto@robins.af.mil>>.

For Marine Corps submit notice of discrepancies or suggested changes on a NAVMC 10772. The NAVMC may be submitted via the Internet using website <<http://pubs.ala.usmc.mil/front.htm>>, scrolling down to the NAVMC 10772 Tracking Program and following instructions provided. It may also be submitted by electronic mail to <<mailto:mbmatcommarlogbases@logcom.usmc.mil>>, or by mailing paper copy NAVMC 10772 in an envelope addressed to Commander, Marine Corps Systems Command, Attn: Assistant Commander Acquisitions and Logistics (LOG/TP), 814 Radford Blvd, Suite 20343, Albany, Georgia 31704-0343.

In any case we will send you a reply.

TABLE OF CONTENTS

WP Sequence No. and/or Page No.

WARNING SUMMARY	a
HOW TO USE THIS MANUAL	iii
CHAPTER 1 – INTRODUCTORY INFORMATION WITH THEORY OF OPERATION FOR 100 kW TACTICAL QUIET GENERATOR SET	
General Information	0001 00
Equipment Description and Data.....	0002 00
Theory of Operation.....	0003 00
Supporting Data for Repair Parts, Special Tools, TMDE, and Support Equipment	0004 00
CHAPTER 2 – OPERATOR INSTRUCTIONS FOR 100 kW TACTICAL QUIET GENERATOR SET	
Description and Use of Operator Controls and Indicators.....	0005 00
Operation Under Usual Conditions	0006 00
Operation Under Unusual Conditions.....	0007 00
CHAPTER 3 – OPERATOR TROUBLESHOOTING PROCEDURES FOR 100 kW TACTICAL QUIET GENERATOR SET	
Introduction	0008 00
Malfunction/Symptom Index.....	0009 00
Troubleshooting Procedures.....	0010 00
CHAPTER 4 – OPERATOR MAINTENANCE INSTRUCTIONS FOR 100 kW TACTICAL QUIET GENERATOR SET	
Service Upon Receipt	0011 00
Preventive Maintenance Checks and Services (PMCS), Including Lubrication Instructions	0012 00
Control Box Assembly Maintenance.....	0013 00
Engine Air Cleaner Maintenance.....	0014 00
Engine Cooling System Maintenance.....	0015 00
Engine Fuel System Maintenance	0016 00
Engine Lubrication System Maintenance	0017 00
Preparation for Storage or Shipment	0018 00
CHAPTER 5 – SUPPORTING INFORMATION FOR 100 kW TACTICAL QUIET GENERATOR SET	
References	0019 00
Components of End Item (COEI) and Basic Issue Items (BII) Lists	0020 00
Additional Authorized List (AAL).....	0021 00
Expendable and Durable Items List	0022 00
Warranty Information	0023 00
GLOSSARY	Glossary-1
INDEX	Index-1

HOW TO USE THIS MANUAL

This manual contains operator instructions for the 100 kW Tactical Quiet Generator Set (TQG), Skid-Mounted MEP-807A and for the Tactical Quiet Generator Set, Trailer-Mounted PU-807A. The TQG can be mounted on a 5-ton trailer, Model XM1061E1. Detailed operation and maintenance information for the trailer is in TM 9-2330-376-14&P.

Refer to References work package WP 0019 00, located in Chapter 5, for a listing of other related manuals.

This operator's manual is part of a family of manuals which includes a Unit, Direct and General Support Maintenance Manual (TM 9-6115-729-24) and a Repair Parts and Special Tools Lists (RPSTL) (TM 9-6115-729-24P). The manuals implement the Army Maintenance Transformation and change the Maintenance Allocation Chart (MAC) located in (TM 9-6115-729-24) to support Field and Sustainment Maintenance under the new Two-Level Maintenance Concept.

This manual is written in Work Package (WP) format.

The Table of Contents will help you understand the organization of the manual and will direct you to the major sections. It lists the specific work packages contained in each chapter. Details such as operational instructions or information about parts of the TQG can be located by using the index at the end of the manual.

NOTE

The generator end of the TQG is referred to as the REAR of the TQG. The control panel is also located on the generator end (REAR) of the TQG. Figure 1 (Sheets 1-6) in WP 0002 00 shows where TQG components are located.

Chapter 1 contains general information work packages including required maintenance forms, records, and reports; and where to find safety and warranty information about the TQG. The chapter also contains WPs that describe the equipment and data including location of major components and theory of operation.

Chapter 2 work packages describe controls and indicators and operating instructions, including operation under usual conditions and operating under unusual conditions.

Chapter 3 work packages contain a malfunction index and troubleshooting procedures. Chapter 3, WP 0009 00, Malfunction/Symptom Index, also contains a table listing all of the Alarm Codes and Fault Codes for the TQG engine and control systems, including the Digital Voltage Regulator (DVR). This WP tells you what to do when you see these fault codes and how to use them.

Chapter 4 work packages contain PMCS and maintenance procedures that you are authorized to perform.

Chapter 5 work packages provide general reference information and list of Components of End Item (COEI) and Basic Issue Items List (BII), Additional Authorized List (AAL) and Expendable and Durable Items List. This Chapter also contains detailed Warranty Information including manufacturers' warranted list of components.

While performing the procedures in this manual, you may find errors and/or make recommended changes that will improve the manual. At the back of this manual, you will find copies of DA Form 2028 which invite you to submit your suggestions digitized or on paper.

HOW TO USE THIS MANUAL – Continued

MAINTENANCE WORK PACKAGES

Read the INITIAL SETUP section carefully before you start any maintenance procedure. Get the tools and supplies listed and the personnel needed.

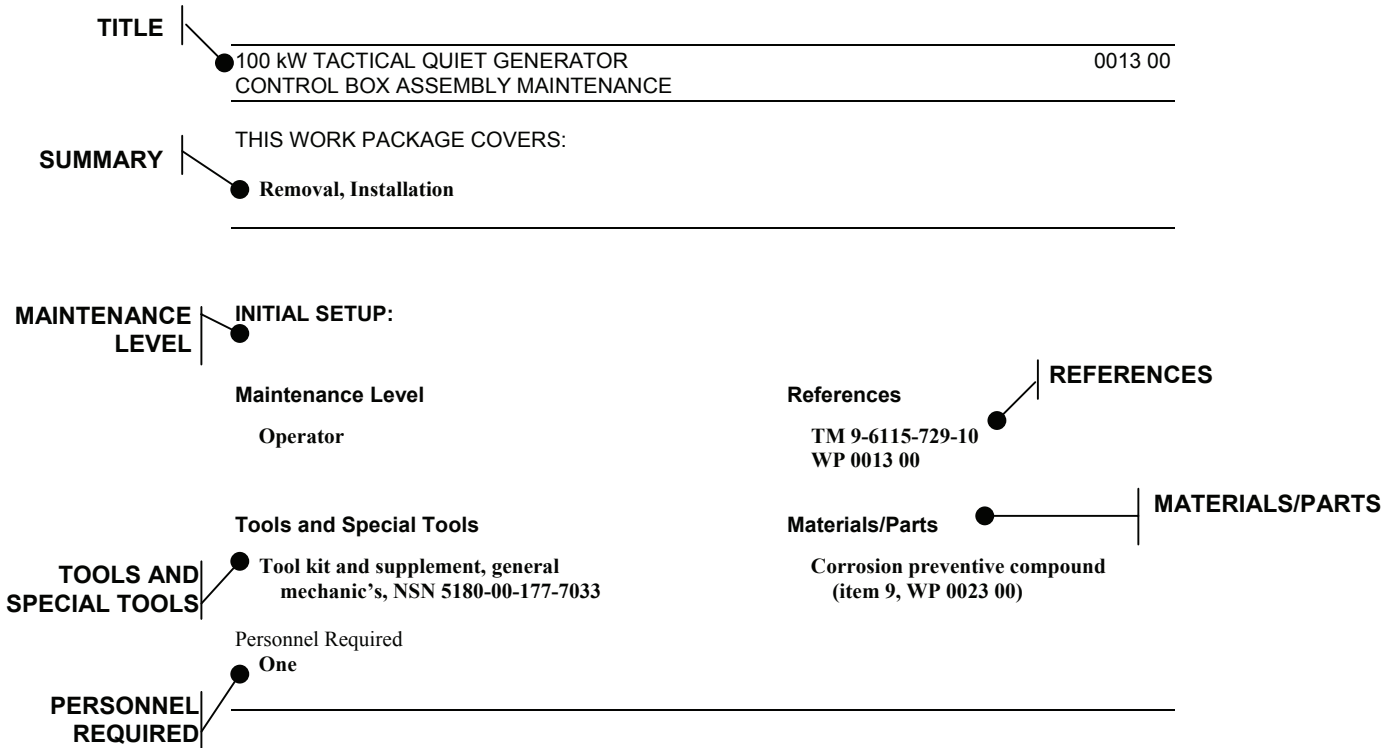

LEGEND:

TITLE	The name of the procedure.
SUMMARY	A listing of the general actions to be performed.
MAINTENANCE LEVEL	The level of maintenance authorized to do the procedures.
TOOLS AND SPECIAL TOOLS	The tools and equipment needed to do the procedures.
PERSONNEL REQUIRED	The personnel needed to do the procedures.
REFERENCES	Other work packages, manuals, and publications needed to do the procedure.
MATERIALS/PARTS	The supplies and parts needed to do the procedures.

CHAPTER 1

**INTRODUCTORY INFORMATION WITH THEORY OF OPERATION
FOR
100 kW TACTICAL QUIET GENERATOR SET**

CHAPTER 1

INTRODUCTORY INFORMATION WITH THEORY OF OPERATION FOR 100 kW TACTICAL QUIET GENERATOR SET

WORK PACKAGE INDEX

<u>Title</u>	<u>WP Sequence No.</u>
GENERAL INFORMATION.....	0001 00
EQUIPMENT DESCRIPTION AND DATA.....	0002 00
THEORY OF OPERATION	0003 00
SUPPORTING DATA FOR REPAIR PARTS, SPECIAL TOOLS, TMDE, AND SUPPORT EQUIPMENT	0004 00

**100 kW TACTICAL QUIET GENERATOR SET
GENERAL INFORMATION**

0001 00

SCOPE

This technical manual (TM) contains instructions for operation, operator maintenance, checks and adjustments, theory of operation, troubleshooting, and corrective maintenance for the 100 kW Tactical Quiet Generator Set, MEP-807A and PU-807A.

Type of Manual: Operator, crew maintenance.

Model Number and Equipment Name: Generator Set, Skid-Mounted, Tactical Quiet, 100 kW, 50/60 Hz, MEP-807A, and Generator Set, Trailer-Mounted, Tactical Quiet, 100 kW, 50/60Hz, PU-807A.

Purpose of Equipment: The 100 kW TQG provides 120/208 Vac or 240/416 Vac, 50/60 Hz, 3-phase power for a wide variety of military applications, offering the mobility and operational characteristics demanded by modern armed forces. Operational characteristics include the ability to operate at all possible humidity levels, at ambient temperature levels from -25°F to +120°F (-32°C to +49°C) down to -50°F (-46°C) with winterization kit, and at altitudes up to 10,000 feet.

CONSOLIDATED INDEX OF ARMY PUBLICATIONS AND BLANK FORMS

Refer to the latest issue of DA PAM 25-30 to determine whether there are new additions, changes, or additional publications pertaining to the equipment.

MAINTENANCE FORMS, RECORDS, AND REPORTS

- a. Army Reports of Maintenance and Unsatisfactory Equipment. Department of the Army forms and procedures used for equipment maintenance will be those prescribed by DA PAM 738-750, as contained in the current Maintenance Management Update (The Army Maintenance Management System (TAMMS)). Fill out and forward to the TAMMS clerk, DD Form 5988-E, automated form in the Unit Level Logistics System (ULLS), generated Equipment Maintenance and Inspection Worksheet. When no automation is available, use DA Form 2404, Equipment Inspection and Maintenance Worksheet.

Air Force personnel will use AFR 66-1 for maintenance reporting and TO 00-35D-54 for unsatisfactory equipment reporting.

Marine Corps Units using Asset Tracking Logistics and Supply System (ATLASS) will maintain the forms and records information in accordance with the applicable ATLASS requirements. All other Marine Corps Units will maintain forms and records associated with the operation and maintenance of ground equipment as prescribed by TM 4700-15.

- b. Reporting of Item and Packaging Discrepancies. Army and Air Force users fill out and forward SF 364 (Supply Discrepancy Report (SDR)) as prescribed in AR 735-11-2/DLAR 4140.55/SECNAVINST 4355.18A/AFJ 23-215.4430.3J

For shipping discrepancies, Marine Corps users fill out and forward SF 364 as prescribed in UM 4400-123, UM 4400-124 and SecNavInst 4355.18 to the Source of Supply (SOS).

For packing discrepancies, Marine Corps users fill out and forward SF 364 as prescribed in UM 4400-123, UM 4400-124 and SecNavInst 4355.18 to the applicable control point identified in the SecNavInst.

- c. Transportation Discrepancy Report (TDR) (SF 361). Army users fill out and forward Transportation Discrepancy Report (TDR) (SF 361) as prescribed in AR 55-38/NAVSUPINST 4610.33C/AFR 75-18/MCO P4610.19D/DLAR 4500.15.

Marine Corps users fill out and forward SF 361 as prescribed in DoD 4500.9-R, Defense Transportation Regulation, Part II, Cargo Movement.

**100 kW TACTICAL QUIET GENERATOR SET
GENERAL INFORMATION – Continued**

0001 00

REPORTING EQUIPMENT IMPROVEMENT RECOMMENDATIONS (EIR)

If your 100 kW Tactical Quiet Generator Set needs improvement, let us know. Send us an EIR. You, the user, are the only one who can tell us what you don't like about your equipment. Let us know why you don't like the design or performance. Put it on an SF Form 368, Product Quality Deficiency Report (PQDR). EIRs should be mailed directly to:

Commander
U.S. Army Communications - Electronics Life Cycle Management Command (C-E LCMC)
ATTN: AMSEL-LC-LEO-E-ED
Fort Monmouth, New Jersey 07703-5006

EQUIPMENT DEFICIENCY REPORTING

- a. USAF Deficiency Reporting and Investigating System, TO 00-35D-54, Appendix A procedures will be used for electronic submission. Submit mailed SF 368 forms to:
Warner-Robins AFB
WRALC/LGMTC
375 Perry Street
Robins, AFB GA 31098-1865
- b. U.S. Marine Corps Units submit all fit, form, or function deficiencies in accordance with standard Product Quality Deficiency Reporting (PQDR) procedures contained in TM 4700-15/1 and MCO 4855.10 to Navy PDREP automated system by going to site <<http://www.nslcptsmh.navsea.navy.mil/pdrep/pdrep.htm>>, requesting access and then filling out the PQDR. For additional assistance, e-mail address <mbmatcompqdrs@logcom.usmc.mil>.

Deployed units only may mail PQDR to:

Marine Corps LogCom Command Element
Attn: Quality Assurance Office (L15)
814 Radford Blvd, Suite 20330
Albany, GA 31704-0330

A reply will be furnished to you.

CORROSION PREVENTION AND CONTROL (CPC)

CPC of Army and Marine Corps materiel is a continuing concern. It is important that any corrosion problems with this item be reported so that the problem can be corrected and improvements can be made to prevent the problem in future systems. While corrosion is typically associated with rusting of metals, it can also include deterioration of other materials such as rubber and plastic. Unusual cracking, softening, swelling, or breaking of these materials may be a corrosion problem. If a corrosion problem is identified, it can be reported using Standard Form SF Form 368, Product Quality Deficiency Report. Use of key words such as "corrosion," "rust," "deterioration," or "cracking" will ensure that the information is identified as a CPC problem. The form should be submitted to the address specified in DA PAM 738-750. Air Force personnel use TO 25-1-3.

DESTRUCTION OF ARMY MATERIEL TO PREVENT ENEMY USE

Refer to TM 750-244-2 for demolition procedures when equipment destruction is required.

**100 kW TACTICAL QUIET GENERATOR SET
GENERAL INFORMATION – Continued**

0001 00

WARRANTY INFORMATION

See WP 0023 00 for detailed information concerning the WARRANTY PERIOD and list of warranted components. Report all defects to your supervisor, who will take appropriate action.

NOMENCLATURE CROSS-REFERENCE LIST

Nomenclature for common names is listed alphabetically with a cross-reference to the official nomenclature (i.e., Maintenance Allocation Chart (MAC), Repair Parts and Special Tools Lists (RPSTL)).

Common Name

100 kW TQG

Official Nomenclature

Generator Set, Skid Mounted, Tactical Quiet, 100 kW, 50/60 Hz, MEP-807A

Generator Set, Trailer Mounted, Tactical Quiet, 100 kW, 50/60 Hz, PU-807A

LIST OF ABBREVIATIONS/ACRONYMS**Abbreviation/Acronym**

AAL

AC

AMP

ATLASS

AUX

BAT

BII

BIT

CAGE

CBR

CCW

COEI

CPC

CTA

CW

DC

DVR

ECM

EMI

EMCP

ESD

GFE

GFCI

GND

Definition

Additional Authorization List

Alternating Current

Ampere

Asset Tracking Logistics and Supply System

Auxiliary

Battery

Basic Issue Items

Built-in-Test

Commercial and Government Entity

Chemical, Biological, and Radiological

Counterclockwise

Components of End Item

Corrosion Prevention and Control

Common Table of Allowances

Clockwise

Direct Current

Digital Voltage Regulator

Engine Control Module

Electromagnetic Interference

Electronic Modular Control Panel

Electrostatic Discharge

Government Furnished Equipment

Ground Fault Circuit Interrupter

Ground

LIST OF ABBREVIATIONS/ACRONYMS – Continued

<u>Abbreviation/Acronym</u>	<u>Definition</u>
GSC	Generator Set Control
Hz	Hertz (cycles per second)
kPa	KiloPascal
KVAR	Kilovolt-ampere-reactive
KVARHr	Kilovolt-ampere-reactive hour
kVA	Kilovolt-ampere
kWh	Kilowatt hour
kW	Kilowatt
JTA	Joint Table of Allowances
LCD	Liquid Crystal Display
LED	Light Emitting Diode
MAC	Maintenance Allocation Chart
MTOE	Modified Table of Organization and Equipment
NATO	North Atlantic Treaty Organization
NBC	Nuclear, Biological, and Chemical
PF	Power Factor
PMCS	Preventive Maintenance Checks and Services
PN	Part Number
PQDR	Product Quality Deficiency Report
RPSTL	Repair Parts and Special Tools Lists
SDR	Supply Discrepancy Report
SOS	Source of Supply
TAMMS	The Army Maintenance Management System
TDA	Table of Distribution and Allowances
TDR	Transportation Discrepancy Report
TM	Technical Manual
TMDE	Test Measurement and Diagnostic Equipment
TQG	Tactical Quiet Generator
U/M	Unit of Measure
ULLS	Unit Level Logistics System
USEPA	U. S. Environmental Protection Agency
Vac	Volts Alternating Current
Vdc	Volts Direct Current

SAFETY, CARE, AND HANDLING

The TQG contains no radioactive components or parts or radioactive material requiring special handling or consideration. The TQG contains no electronic modules or components requiring special handling to protect them from electrostatic discharge (ESD).

This manual describes physical and chemical processes that may require the use of chemicals, solvents, paints, or other commercially available material. Users of the manual should obtain the material safety data sheets (Occupational Safety and Health Act (OSHA) Form 20 or equivalent) from the manufacturers or suppliers of materials to be used. Users must be completely familiar with manufacturer/supplier information and adhere to their procedures, recommendations, warnings, and cautions for safe use, handling, storage, and disposal of these materials.

**100 kW TACTICAL QUIET GENERATOR SET
EQUIPMENT DESCRIPTION AND DATA**

0002 00

EQUIPMENT CHARACTERISTICS, CAPABILITIES, AND FEATURES

The 100 kW Tactical Quiet Generator (TQG) is skid-mounted and is designated MEP-807A. When the 100 kW TQG is mounted on a trailer, it is designated PU-807A. The 100 kW TQG consists of a diesel engine that can operate using diesel fuel or aviation fuel, a brushless alternating current (AC) generator, a digital voltage regulator, an electronic governing system, a fuel system, a 24 Vdc cranking system, and other devices as described below to achieve a complete engine driven generator set. The system uses the Caterpillar 3126B engine and a Marathon generator model DOD 431 FR. The engine is electronically controlled. The electronic control is essential to meeting U.S. Environmental Protection Agency (USEPA) and fuel consumption requirements. All the electrical components and assemblies (including the voltage regulator) that provide the required instrumentation and control functions are contained in the Electronic Modular Control Panel (EMCP) located on the generator end (REAR) of the TQG as shown in figure 1, sheet 3. Opening the EMCP and side access panels gives access to all the electrical components and essential engine components. Paralleling receptacles are used to connect the paralleling cable between generator sets of the same family. The generator set family includes a 200 kW TQG. The 200 kW TQG is skid-mounted and is designated MEP-809A. When the 200 kW TQG is mounted on a trailer, it is designated PU-809A. The 200kW generator sets (MEP 809A) and (PU 807A) use the same control system as the 100kW generator sets (MEP-807A) and (PU-807A) and can operate in parallel to share an electrical load.

LOCATION AND DESCRIPTION OF MAJOR COMPONENTS**ENGINE**

The engine for the 100 kW TQG is the Caterpillar Model 3126B engine (figure 1, sheet 1, item 4). The engine is electronically controlled. The Engine Control Module (ECM) controls the amount of fuel that is injected by the unit injectors. The EMCP provides frequency (speed) control, controls long and short-term stability, and accommodates load conditions. High injection pressures help to reduce fuel consumption and emissions. Precise injection timing optimizes engine performance for starting, emissions, noise and fuel consumption.

AIR CLEANER ASSEMBLY

The air cleaner assembly (1) is located on the left side of the engine inside the rear access doors. The air cleaner filters intake air used for engine combustion.

MUFFLER

The muffler (2) and exhaust tubing are connected to the engine and turbocharger. This system reduces engine exhaust noise. Exhaust gases are exhausted upward from the top of the generator set.

TURBOCHARGER

The turbocharger (3) is located on the right side of the engine. Powered by engine exhaust gases, the turbocharger compresses air from the air filter to provide pressurized air to the engine for combustion.

ALTERNATOR

The alternator (5) is located on the right side of the engine. The alternator maintains the batteries in a state of full charge. The alternator also provides 24 Vdc voltage for TQG control circuits and to the NATO slave receptacle. After the alternator comes on line after starting the engine, the voltage output is 28 ± 2 Vdc.

RADIATOR

The radiator (6) located at the front of the TQG eliminates engine heat via circulated coolant and air. The radiator and engine fan are the primary heat exchanger for cooling engine coolant and for turbocharged engine intake air.

WATER PUMP

The water pump (7) located on the right side of the engine circulates coolant through the engine block and radiator to cool the engine.

LOCATION AND DESCRIPTION OF MAJOR COMPONENTS – Continued

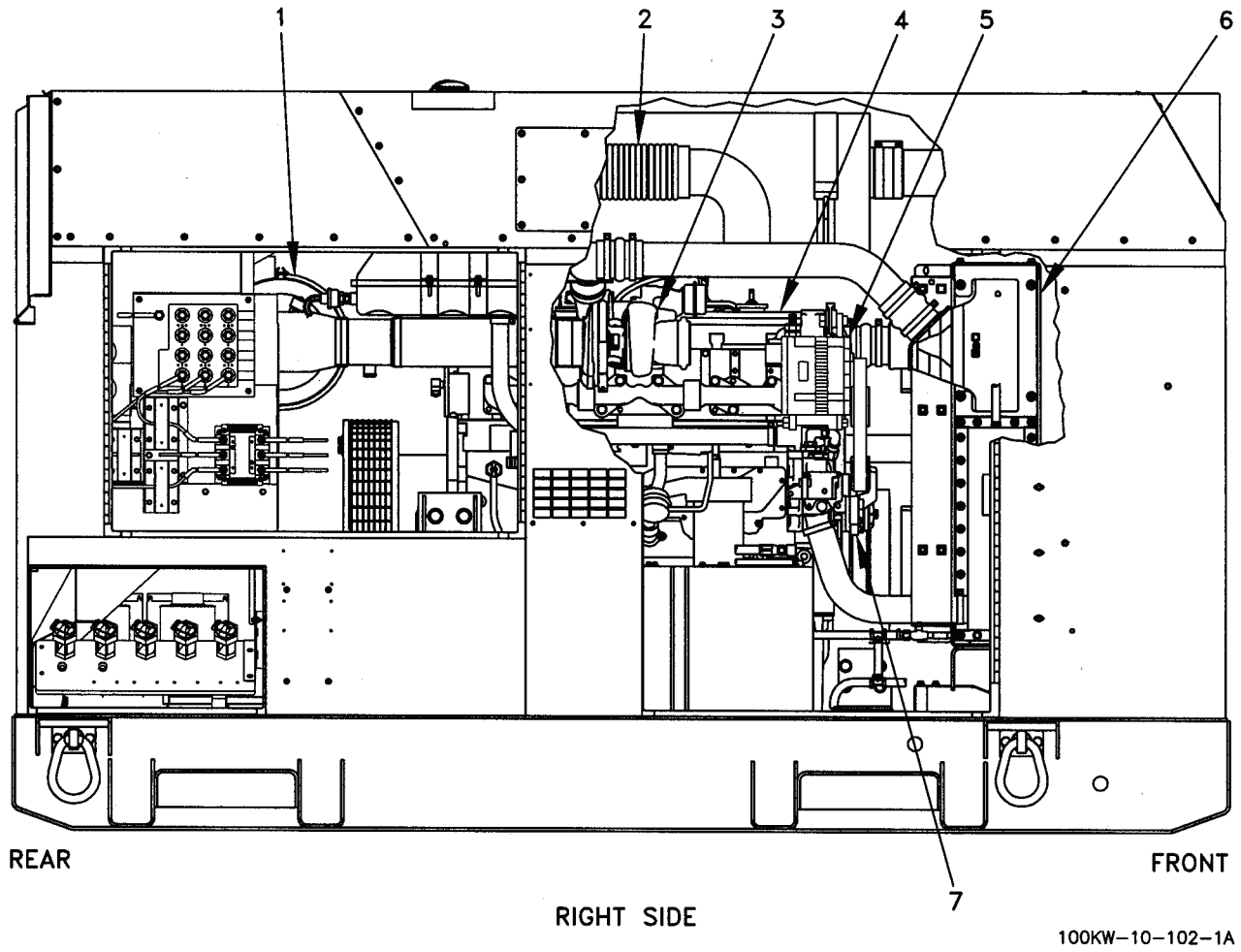

Figure 1. 100 kW Tactical Quiet Generator Location of Components (Sheet 1 of 6)

LOCATION AND DESCRIPTION OF MAJOR COMPONENTS – Continued

STARTER

The engine starter motor (figure 1, sheet 2, item 8) is located on the right rear side of the engine. The electric starter engages the flywheel mechanically to start the diesel engine.

LOAD BOARD

The load board (9) connects load cables to the TQG with heavy duty connector lugs and nuts.

RECONNECTION BOARD

The reconnection board (10) is used to change generator output voltage for different load applications. The TQG can be configured for 120/208 Vac or 240/416 Vac operation for 50 Hz or 60 Hz.

MAIN CONTACTOR

The main contactor K1 (11) controls generator load output to the load.

AC GENERATOR

The generator (12) used in the 100 kW TQG is Marathon Electric model DOD 431 FR, designed to meet military applications for the TQG. The generator is a brushless, single-bearing, rotating-rectifier generator. It is close-coupled to the engine via flexible drive disks. Each generator is made up of five major components: main stator (armature), main rotor (field), exciter stator (field), exciter rotor (armature), and rotating rectifier assembly.

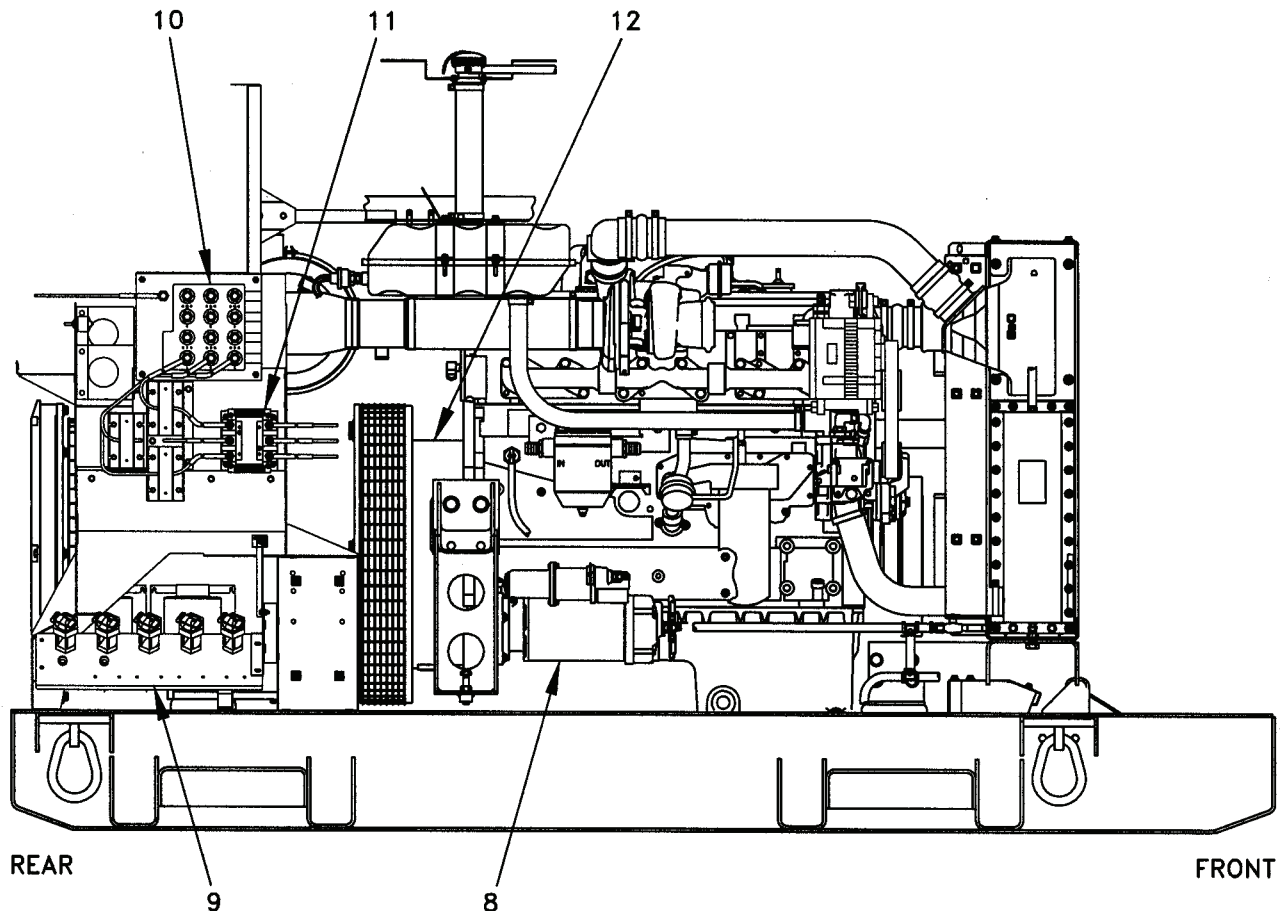

RIGHT SIDE HOUSING REMOVED FOR CLARITY

100KW-10-102-2A

Figure 1. 100 kW Tactical Quiet Generator Location of Components (Sheet 2)

LOCATION AND DESCRIPTION OF MAJOR COMPONENTS – Continued**ELECTRONIC MODULAR CONTROL PANEL**

The TQG EMCP (figure 1, sheet 3, item 13) contains controls and indicators for monitoring TQG operation. Located at the rear end of the generator set, the EMCP contains the Generator Set Control (GSC) (14), an alarm module (15), and a Digital Voltage Regulator (DVR) (16). EMCP displays and indicators allow the operator to monitor all engine and generator functions with alarm and identification of malfunctions. The Malfunction/Symptom Index in WP 0009 00 lists all of the alarm codes and fault codes for TQG malfunctions. The GSC monitors the output frequency of the generator and controls the engine speed to maintain a constant output frequency, regardless of load. The PUSH TO STOP EMERGENCY STOP pushbutton (17) shuts down the TQG immediately when it is pushed.

PARALLELING RECEPTACLES

The PARALLELING RECEPTACLES panel is located to the left of the EMCP. The paralleling receptacles (18) are used to connect the paralleling cable for multiple 100kW or 200kW TQG sets of the same mode. A 1100kW TQG (MEP 807A) (PU 807A) may be paralleled with a 200kW TQG (MEP 809A) (PU 809A) between generator sets of the same family and control system to operate in parallel.

CONVENIENCE RECEPTACLES

Two convenience receptacles (19) are located to the left of the EMCP on the PARALLELING RECEPTACLES panel (18). The receptacles rated 120 Vac, 15A are available at all times during generator operation. The receptacles are protected by a GROUND FAULT CIRCUIT INTERRUPTER with TEST and RESET functions (20). The frequency of the voltage output at the convenience receptacle outlets is set by generator frequency and will be 50 Hz or 60 Hz.

DEAD CRANK SWITCH

The dead crank switch (figure 1, sheet 4, item 22) is located inside the generator housing at the left rear. During maintenance, the dead crank switch allows the engine to be cranked without starting the engine.

NATO SLAVE RECEPTACLE

The NATO slave receptacle (23) is located on the left side (front) of the TQG. It is used for 24 Vdc slave starting.

BATTERIES

Two sealed 12 Vdc batteries (24), located at the front of the generator, are connected in series. Batteries provide power for EMCP controls, engine starting, and to the NATO slave receptacle. These batteries can be disconnected with the Battery Disconnect Switch (25).

WINTERIZATION KIT (ISSUED TO SELECTED UNITS ONLY)

The winterization kit consists of a fuel-fired heater (26) to heat engine coolant and connecting control wiring and tubes. The kit also includes resistor heaters located in EMCP. The fuel-fired heater is controlled with the winterization kit control panel (figure 1, sheet 3, item 21).

100 kW TACTICAL QUIET GENERATOR SET
EQUIPMENT DESCRIPTION AND DATA – Continued

0002 00

LOCATION AND DESCRIPTION OF MAJOR COMPONENTS – Continued

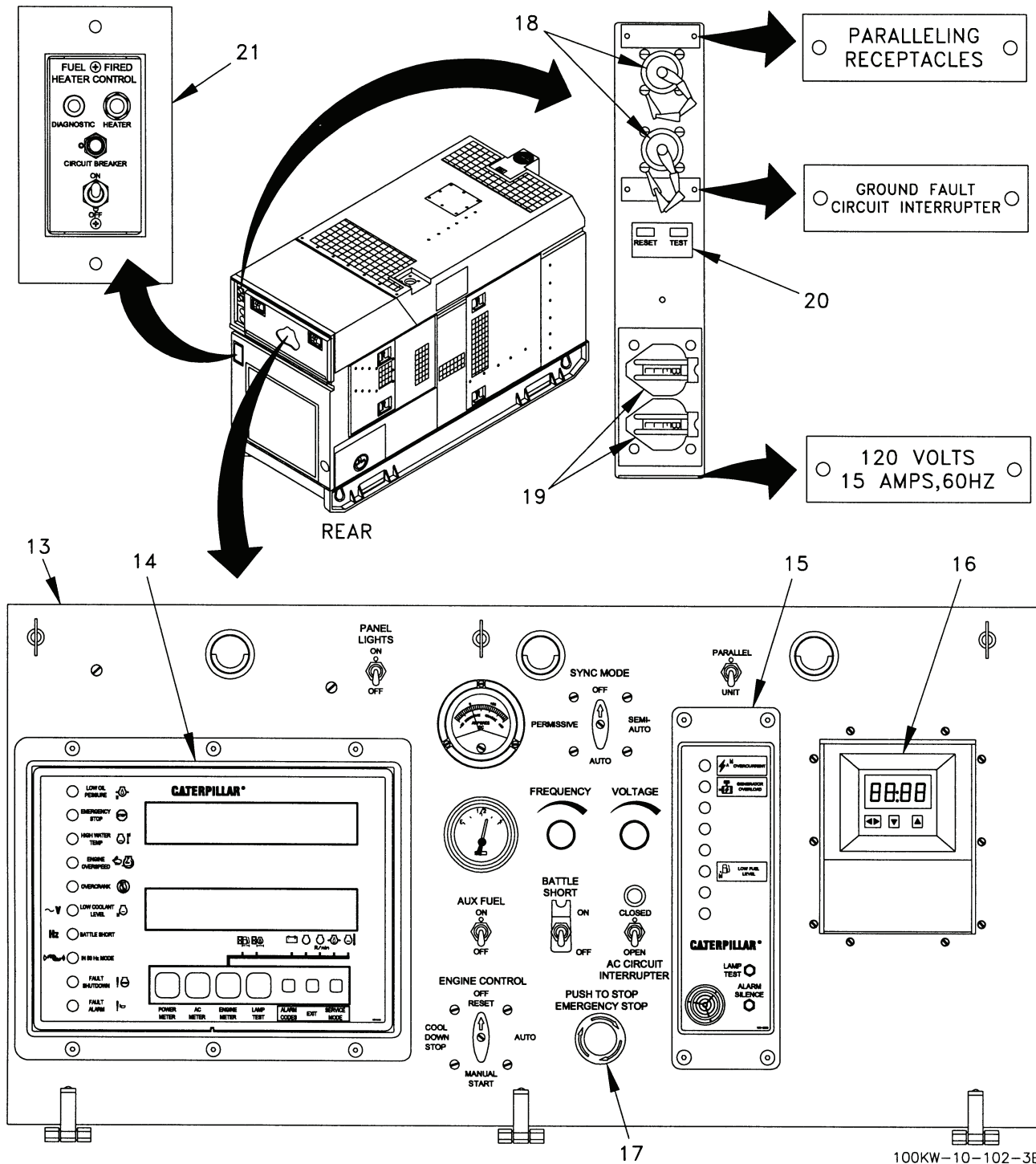

100KW-10-102-3B

Figure 1. 100 kW Tactical Quiet Generator Location of Components (Sheet 3)

LOCATION AND DESCRIPTION OF MAJOR COMPONENTS – Continued

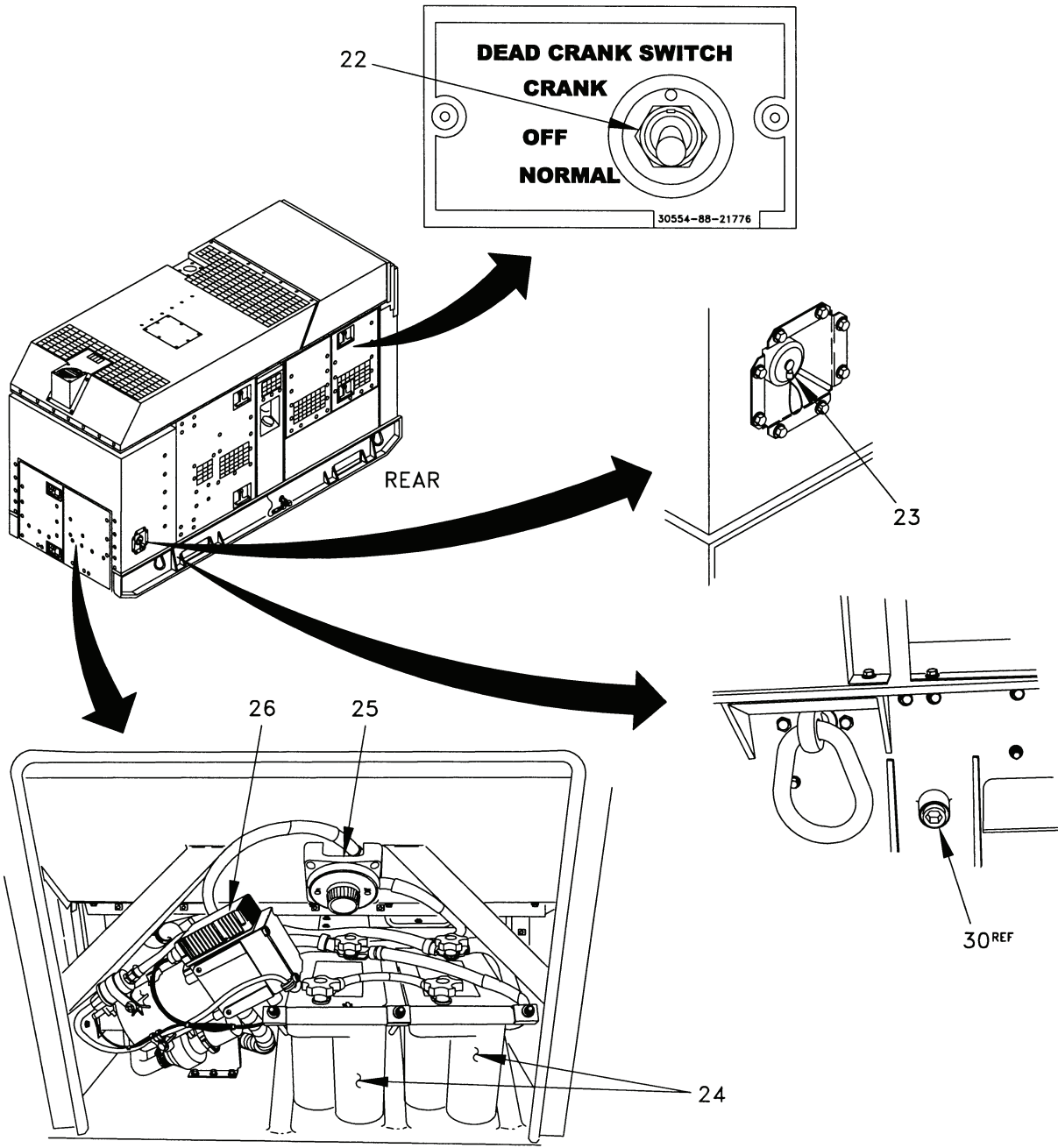

100KW-10-102-4B

Figure 1. 100 kW Tactical Quiet Generator Location of Components (Sheet 4)

LOCATION AND DESCRIPTION OF MAJOR COMPONENTS – Continued

SKID BASE

The skid base (figure 1, sheet 5, item 27) provides the main structural support for the engine and generator. The skid base consists primarily of two formed side rails, cross members, mounting pads, forklift openings, and a bottom plate. Main cross members complete the primary skid base structure to support the engine and generator mounting pads and vibration isolators and reinforce the fork lift openings (28). Four 25,000 lb (11,400 kg) capacity LIFT/TIEDOWN rings (29) are attached to the skid base frame. In addition to supporting the engine generator assembly, housing, battery and other components, the skid base has provisions for engine oil drain (30), coolant drain (opposite side), a water separator drain (31), and fuel tank drain (32). The skid base also serves as a support and protective enclosure for the fuel tank.

FUEL TANK

The fuel tank (33) is a 66 gallon (250L) molded tank located below the diesel engine between the skid assembly side members.

ENGINE CONTROL MODULE

The ECM (34) monitors most of the engine sensors and controls the fuel injectors and engine timing functions.

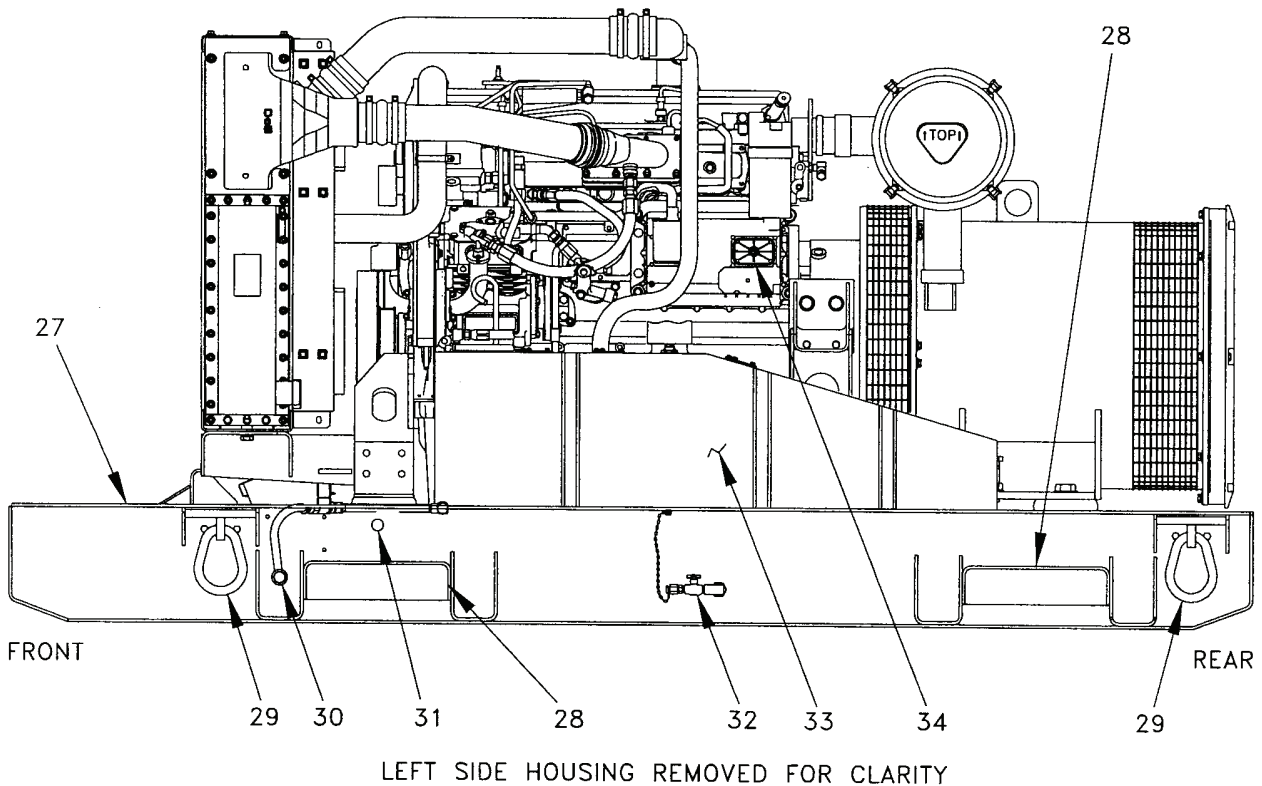

Figure 1. 100 kW Tactical Quiet Generator Location of Components (Sheet 5)

LOCATION AND DESCRIPTION OF MAJOR COMPONENTS – Continued

GENERATOR HOUSING INSTALLATION

The housing (figure 1, sheet 6, item 35) is fabricated from sheet steel and attaches directly to mating flanges on the skid base. The housing is thus removable for unscheduled maintenance and engine or generator removal. Access openings and doors (36) allow engine, generator, and external component servicing. Each side of the rear housing has a set of double doors and the large doors at the front of the housing provide accessibility. The housing structure incorporates acoustic damping foam and internal baffle structures to reduce engine noise. The rugged design of the housing, includes stiffened corners and access openings to meet transportability, operational, and handling requirements of a mobile military generator set.

TRAILER-MOUNTED CONFIGURATION (PU-807A)

The skid-mounted TQG can be mounted on a model XM1061E1 5-ton trailer (37). In this configuration, the TQG can be towed and positioned as required. In the power unit configuration, the trailer-mounted TQG has an accessory box (38), and two fire extinguishers (39). The TQG skid is bolted directly to the trailer bed and frame.

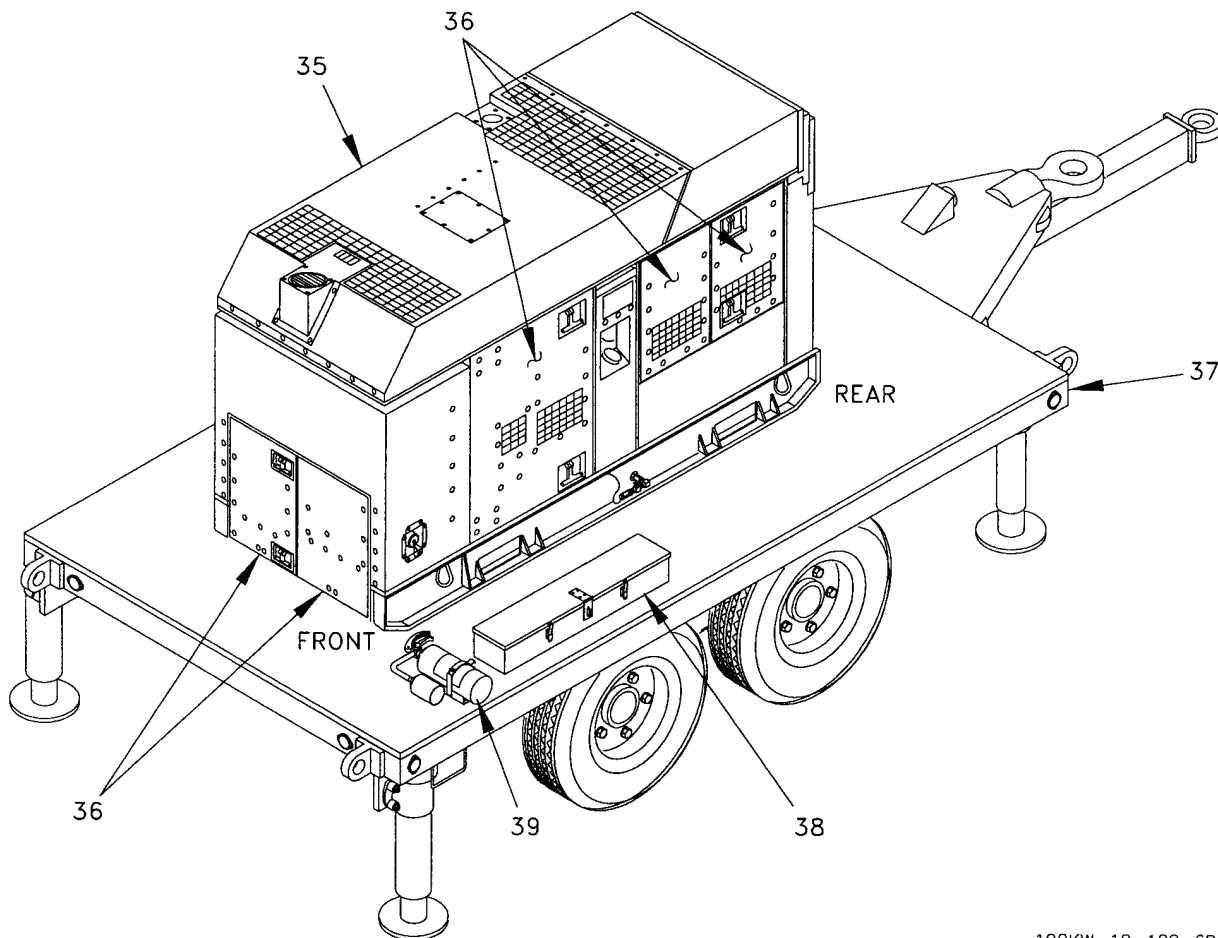

100KW-10-102-6D

Figure 1. 100 kW Tactical Quiet Generator Location of Components (Sheet 6)

**100 kW TACTICAL QUIET GENERATOR SET
EQUIPMENT DESCRIPTION AND DATA – Continued**

0002 00

EQUIPMENT DATA

Table 1 lists equipment data for the 100 kW TQG.

Table 1. 100 kW TQG Equipment Data.

EQUIPMENT	DATA
<p>100 kW Tactical Quiet Generator Set</p> <p>Overall length</p> <p>Width</p> <p>Height</p> <p>Weight</p> <p> Wet (includes fuel)</p> <p> Dry</p> <p>Engine</p> <p> Manufacturer</p> <p> Model</p> <p> Type</p> <p> Horsepower</p> <p> Displacement</p> <p> Valves per cylinder</p> <p> Valve lash setting (cold engine)</p> <p>Cooling system</p> <p> Type</p> <p> Capacity</p> <p> Normal operating temperature</p> <p> Temperature indicating system voltage</p> <p>Lubricating system</p> <p> Type</p> <p> Pump type</p> <p> Capacity</p> <p> Normal operating pressure</p> <p>Fuel system</p> <p> Fuel type</p> <p> Fuel tank capacity</p> <p> Consumption rate</p> <p>Auxiliary fuel pump</p> <p> Manufacturer</p> <p> Voltage rating</p> <p> Delivery rate</p>	<p>MEP-807A</p> <p>106 in. (269 cm)</p> <p>40 in. (102 cm)</p> <p>65 in. (165 cm)</p> <p>6100 lb (2767 kg)</p> <p>5500 lb (2495 kg)</p> <p>Caterpillar</p> <p>3126B</p> <p>Six cylinder, in-line, four cycle, turbocharged diesel</p> <p>280 hp @ 1800 rpm (60 Hz)</p> <p>233 hp @ 1500 rpm (50 Hz)</p> <p>442 in³ (7.25L)</p> <p>Three (two inlet, one exhaust)</p> <p>Inlet: 0.015 in. (0.38 mm)</p> <p>Exhaust: 0.025 in. (0.64 mm)</p> <p>Pressurized radiator and coolant pump</p> <p>38 qt (34.5L)</p> <p>170°F to 200°F (77°C to 93°C)</p> <p>24 Vdc, range programmable</p> <p>Full flow, circulating pressure</p> <p>Positive displacement gear</p> <p>30 qt (27.3L)</p> <p>35 to 70 psi (241 to 483 kPa)</p> <p>DF-1, DF-2, JP5, JP8</p> <p>66 gal (250L)</p> <p>8 hour tank capacity at full load</p> <p>Walbro Corp.</p> <p>24 Vdc (16 to 30 Vdc)</p> <p>34 gph at 30 Vdc; 17 gph at 18 Vdc</p>

EQUIPMENT DATA – Continued

Table 1. 100 kW TQG Equipment Data – Continued.

EQUIPMENT	DATA	
Fuel level switch Manufacturer Type Voltage	Madison Float 24 Vdc	
Inlet air preheater Manufacturer Model Voltage rating	Caterpillar 159-7284 Thermal switch activated, 24 Vdc, 78A	
Engine starting system		
Batteries Manufacturer Voltage	Optima 12 Vdc, qty 2 (sealed units)	
Starter Manufacturer Model Voltage rating Drive type	Caterpillar 207 1551 24 Vdc Direct	
Alternator Manufacturer Model Voltage rating Drive type	Caterpillar 169-3345 24 Vdc, 50A Belt	
Generator Manufacturer Model Type	Marathon DOD 431 FR Alternating current, synchronous, brushless	
Load capacity	100 kW at 60 Hz (1,800 rpm)	83.3 kW at 50 Hz (1,500 rpm)
Current ratings 120/208 Vac connection 240/416 Vac connection	<u>60 Hz</u> 347A 174A	<u>50 Hz</u> 289A 145A
Power factor Cooling Drive type Duty classification	0.8 Fan cooled Direct coupling Continuous	

EQUIPMENT DATA – Continued

Table 1. 100 kW TQG Equipment Data – Continued.

EQUIPMENT	DATA
Governing system	
Load measuring unit	
Manufacturer	Woodward
Model	9907-175
Engine control module	
Manufacturer	Caterpillar
Model	172-2394
GSC Protective Relay Setpoint Values	
Low oil pressure shutdown	26 psi (179 kPa)
High water (coolant) temperature shutdown	230° F (110° C)
Engine overspeed	2120 rpm
Overcrank (total cycle crank time)	90 seconds
High oil temperature shutdown	253° F (123° C)
Overvoltage alarm threshold	125% overvoltage for programmed voltage
Generator overvoltage shutdown threshold	125% of nameplate voltage
Generator undervoltage alarm threshold	82% of programmed voltage
Generator undervoltage shutdown threshold	75% of nameplate voltage
Generator overfrequency alarm threshold	63 Hz for 60 Hz operation; 53 Hz for 50 Hz operation
Generator overfrequency shutdown threshold	66 Hz for 60 Hz operation; 55 Hz for 50 Hz operation
Generator underfrequency alarm threshold	57 Hz for 60 Hz operation; 48 Hz for 50 Hz operation
Generator underfrequency shutdown	57 Hz for 60 Hz operation; 45 Hz for 50 Hz operation
Generator phase overcurrent alarm threshold	160% of nameplate current
Generator total overcurrent alarm threshold	160% of nameplate current
Generator phase overcurrent shutdown threshold	160% of nameplate current
Generator total overcurrent shutdown threshold	160% of nameplate current
Reverse power shutdown	15% to 17%

GENERAL

This work package contains functional descriptions of the generator set and explains how TQG functional systems interact with one another.

ENGINE STARTING SYSTEM

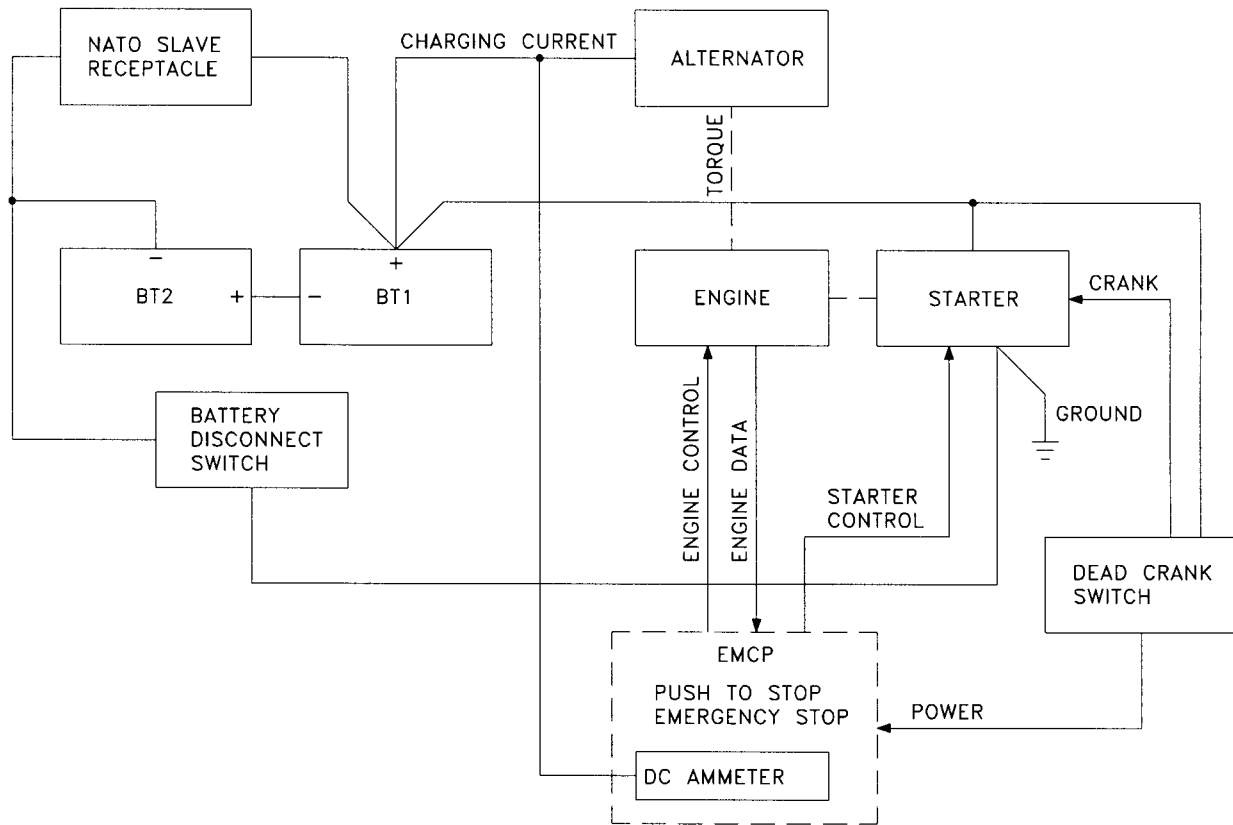

100KW-10-103C

The engine starting system consists of two 12-volt batteries connected in series, a 24 Vdc starter, a 24 volt battery charging alternator, a magnetic pickup (for sensing engine speed) and the related switches and relays required for control of the starting system. The PUSH TO STOP EMERGENCY STOP pushbutton on the EMCP will automatically disable the starting system and shut down the TQG if it is pushed in. For engine cranking, battery power is supplied to the starter motor through the starter solenoid which in turn is controlled by the EMCP. The starter engages the engine flywheel causing the engine to crank. As the engine accelerates to above idle speed (sensed by the magnetic pickup), the EMCP disengages the starter. The starting sequence may also be stopped by moving the ENGINE CONTROL switch on the EMCP to COOL DOWN/STOP. The engine may be cranked without starting by engaging the DEAD CRANK SWITCH. The DEAD CRANK SWITCH is a three-position switch. Up position is CRANK, the center position is OFF, and the lower position is NORMAL (operation). With the DEAD CRANK SWITCH in CRANK position, the starter motor is energized without activating any other starting or control function. With the switch in the OFF center position, the system is off. With the switch in NORMAL (operation) position, the TQG will crank and start. The batteries are charged by the belt-driven battery charging alternator. The battery charging alternator also supplies GSC power. Normal operating indication depends on the state of charge in the batteries. A low charge, such as exists immediately after engine starting, will cause a high reading. Cold outside temperatures make starting the engine difficult. To improve engine starting in cold weather the engine contains a 78A inlet air preheater. This heater is described in the Air Intake and Exhaust System paragraph.

ENGINE STARTING SYSTEM – Continued

The DC battery system provides 24 Vdc for engine starting and TQG control circuits. The two 12 Vdc batteries are charged by the engine alternator. The DC AMMETER on the EMCP indicates alternator charging rate. Charge rate is shown from -25 amperes to +50 amperes, in 5 ampere increments. Normal operating indication depends on the state of charge in the batteries. A low charge, such as exists immediately after engine starting, will cause a high reading. The battery system includes a manually operated Battery Disconnect Switch to isolate the batteries from the engine. The Battery Disconnect Switch can be used to remove DC power from the TQG. Battery condition is also shown on the EMCP lower display ENGINE METER function. The batteries connect directly to the 24 Vdc NATO slave receptacle.

FUEL SYSTEM

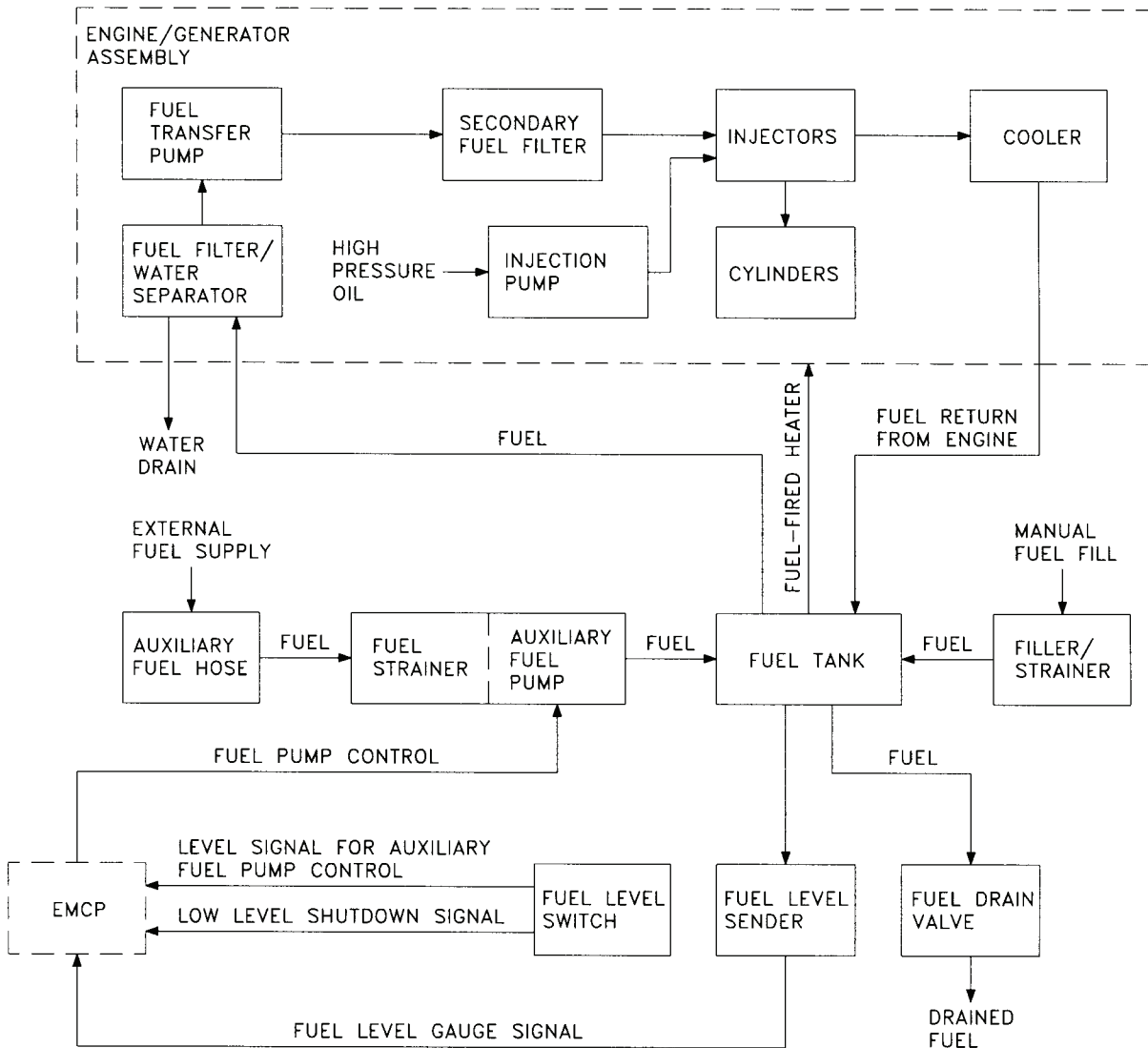

100KW-10-104D

FUEL SYSTEM – Continued

The fuel system consists of hoses, steel injector piping, fuel tank, fuel filter/water separator, transfer pump, injection pump and injectors. Fuel is drawn from the fuel tank by the transfer pump. Fuel passes through a fuel filter/water separator where water and small impurities are removed before arriving at the engine fuel transfer pump. The fuel is then pushed through the secondary fuel filter that removes even smaller particles from the fuel. The fuel then enters the injector manifold and goes into the injectors which are controlled by the ECM and actuated by a hydraulic injection pump that is part of the high pressure oil system. Through the injectors fuel enters the diesel engine combustion chamber, where it is mixed with air and ignited. The fuel that is not used is cooled and returned to the fuel tank via an excess fuel return line. When the fuel level is low, the fuel level switch will either supply power to the external auxiliary fuel pump for external fuel supply or shut down the TQG to prevent it from completely running out of fuel. If a diesel engine runs out of fuel, it is necessary to fill the fuel filters, purge all air from the lines and pumps, and bleed all injectors, one at a time. Only hydraulic pressure will open the injectors; air pressure will not.

AUXILIARY FUEL PUMP

The auxiliary fuel system consists of an external fuel supply, fuel filter, piping, a 24 Vdc auxiliary fuel pump and a fuel level float switch. When the EMCP AUX FUEL switch is ON, auxiliary fuel pump can transfer fuel from the external fuel supply to the generator fuel tank. The fuel level float switch shuts off the auxiliary fuel pump when the generator fuel tank is full and reactivates the pump as the level drops. The fuel level indicator indicates fuel level of generator fuel tank from empty (E) to full (F).

ENGINE COOLING SYSTEM

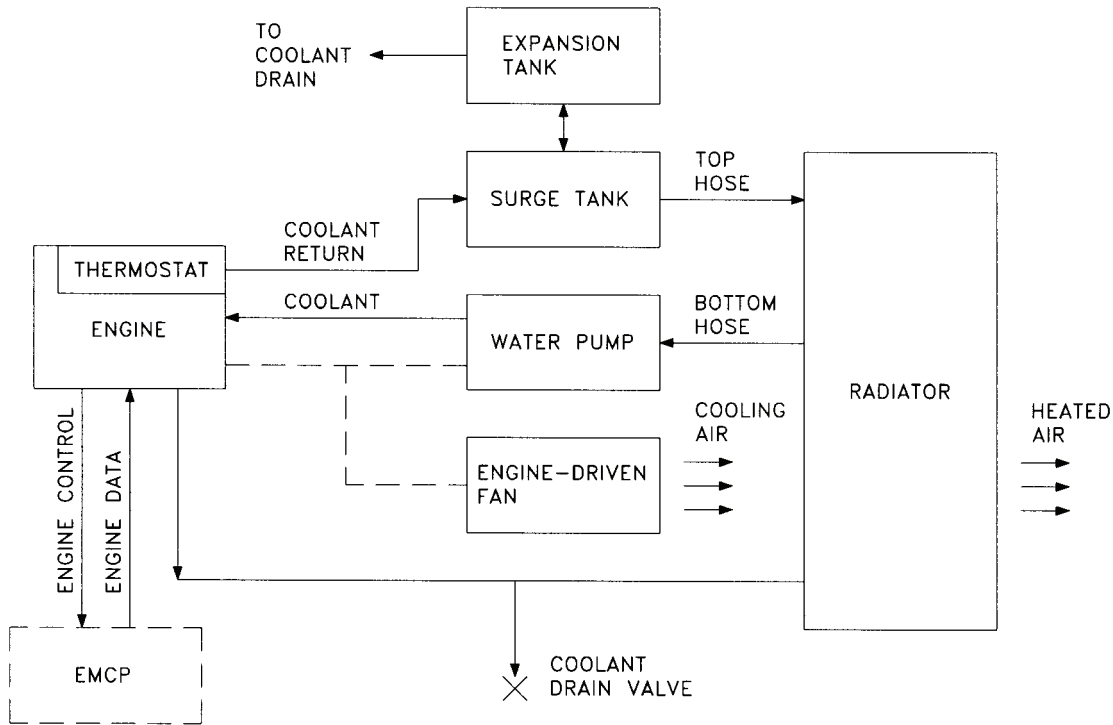

100KW-10-105B

The engine cooling system consists of a radiator, hoses, thermostat, water pump, surge tank and an expansion tank, a belt driven fan, and cooling jackets. The water pump forces coolant through passages (cooling jackets) in the engine block and cylinder head where the coolant absorbs heat from the engine. When the engine reaches normal operating temperature, the thermostat opens and the heated coolant flows through the upper radiator hose assembly into the radiator. The cooling fan circulates air through the radiator where the coolant temperature is reduced. In addition, the fan cools engine and generator set components within the TQG housing by drawing in air from outside the housing through the baffles, circulating the air through the housing, and forcing the air through the radiator and out through the housing exhaust vents on the roof. The housing is designed to operate with the doors closed which ensures that the main alternator and other TQG components have access to a good flow of cooling air from outside the generator set. A coolant temperature sensor provides automatic engine shut down in the event that coolant temperature exceeds 230°F (110°C). The lower GSC display indicates the engine coolant temperature.

LUBRICATION SYSTEM

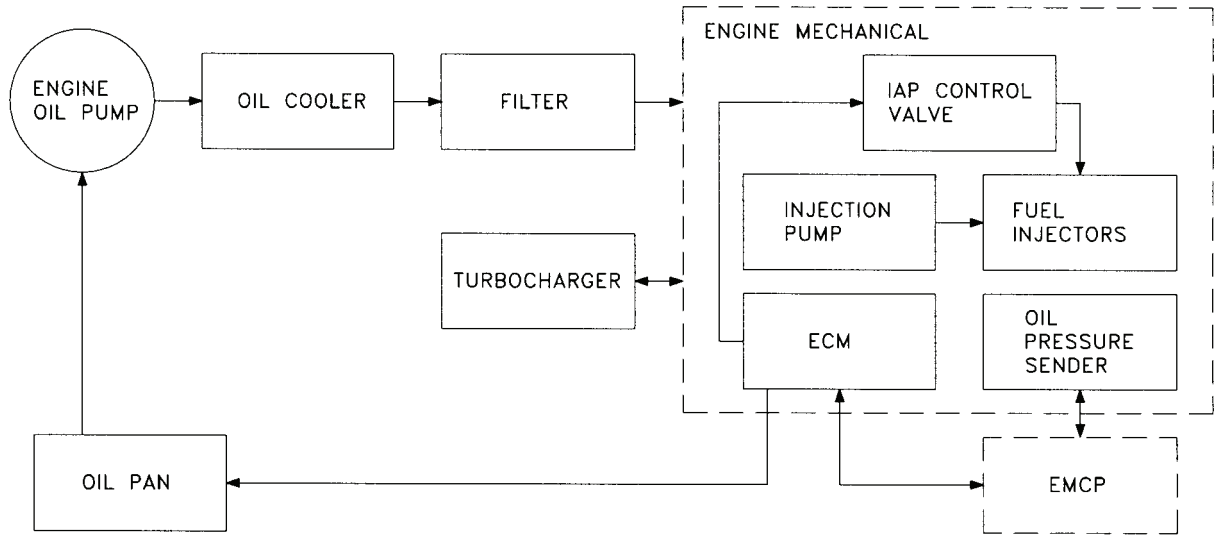

100KW-10-106C

The lubrication system consists of an oil pan, dipstick, pump, cooler, oil pressure sender, and filter. The oil pan is a reservoir for engine lubricating oil. Engine oil lubricates, cleans, cools, seals, and preserves engine parts. The dipstick indicates oil level in the oil pan. A pump draws oil from the oil pan and through a screen that blocks large objects from entering the oil pump and cooler. The oil then passes through a spin-on type filter where smaller impurities are removed. From the filter, oil enters the engine and is distributed to the engine's internal moving parts through internal passageways. Oil is also supplied externally to the turbocharger and internally to a high pressure hydraulic pump that actuates the fuel injectors. After passing through the engine, the oil returns to the oil pan. The lower GSC display indicates oil pressure sensed by the oil pressure sender in the engine. The engine will shut off automatically if the oil pressure drops to 26 psi (179 kPa) and the red LOW OIL PRESSURE indicator on the GSC will flash. The oil level can be checked with engine running.

AIR INTAKE AND EXHAUST SYSTEM WITH TURBOCHARGER

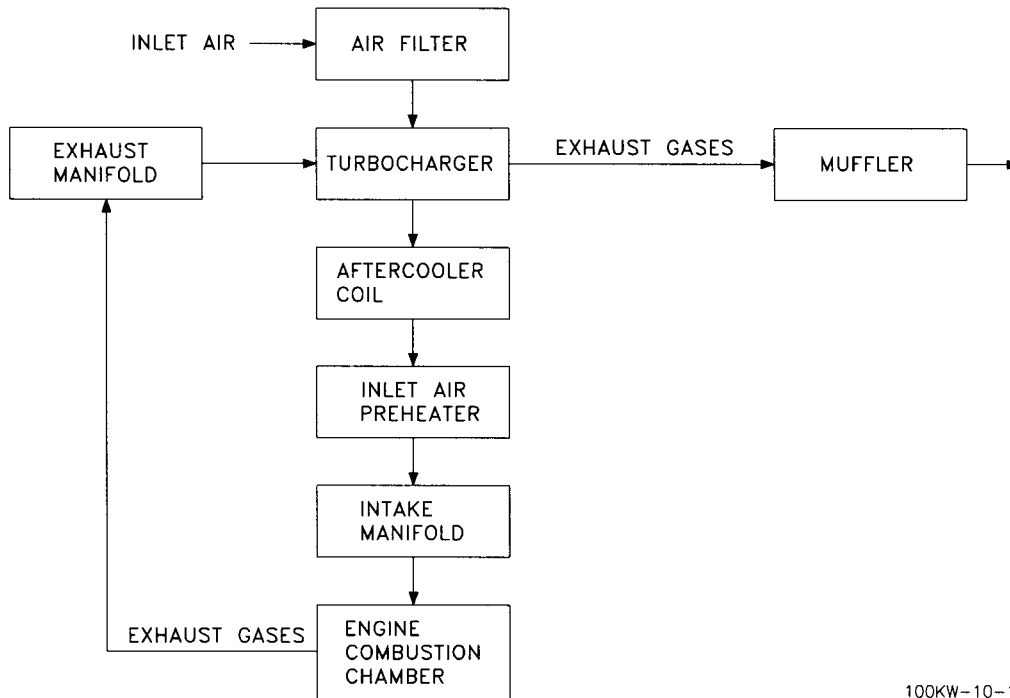

100KW-10-107C

The air intake and exhaust system consists of an air filter assembly, intake manifold, turbocharger, exhaust manifold and muffler. Ambient air is drawn into the air filter assembly where it passes through the filter elements. Airborne dirt is removed and trapped in the elements. Filtered air is drawn out of the air filter assembly through air intake tubes to the turbocharger where it is pressurized and passed through an aftercooler coil in the radiator. In cold weather, an inlet air preheater is activated to warm the inlet air. The pressurized inlet air enters the intake manifold to the combustion chambers and mixes with fuel from the fuel injectors. The engine exhaust gases are released into the manifold then to the turbocharger which is mounted on the exhaust manifold. The exhaust gases drive the turbocharger, forcing large amounts of air into the intake manifold. After passing through the turbocharger, the exhaust gases are channeled into a muffler to deaden the sound.

**100 kW TACTICAL QUIET GENERATOR SET
THEORY OF OPERATION – Continued
AC POWER OUTPUT**

0003 00

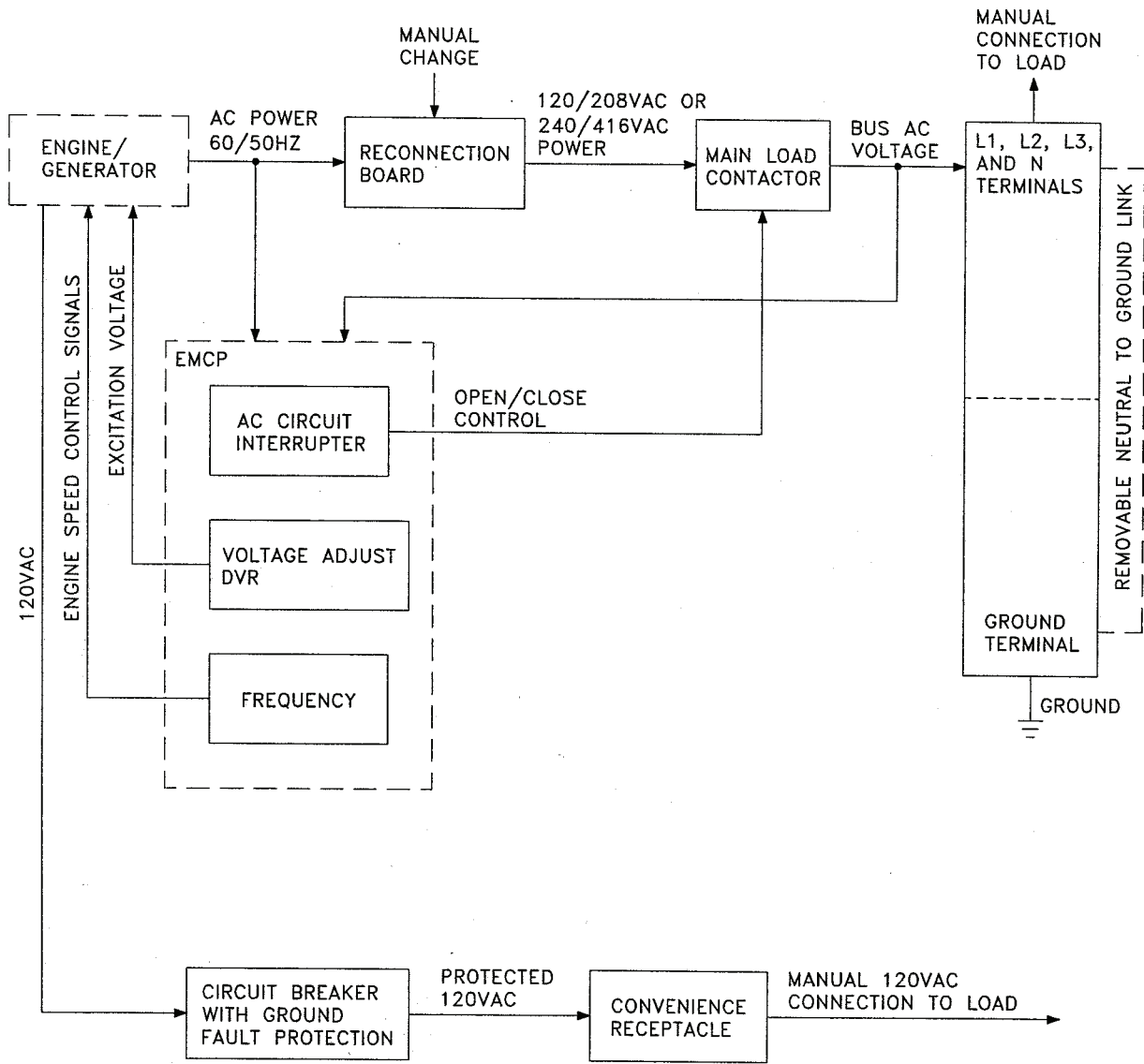

100KW-10-108B

The AC output system consists primarily of the AC generator, the output load terminal board, the voltage reconnection terminal board, the main load contactor and the AC CIRCUIT INTERRUPTER switch on the EMCP. Power created by the AC generator is supplied through the voltage reconnection terminal board and the main load contactor to the output load terminals on the output load terminal board. The voltage reconnection terminal board allows configuration of the generator set for 120/208 volt connections or 240/416 volt connections. The AC CIRCUIT INTERRUPTER switch located on the EMCP closes and opens the main load contactor. This enables or interrupts the power flow between the voltage reconnection terminal board and the output load terminals. The main load contactor is also opened automatically during any of the specified set faults. The DVR module in the EMCP senses AC generator output voltage and provides excitation voltage to the AC generator to maintain the desired output voltage. The VOLTAGE adjust potentiometer is connected to the DVR to allow the operator to adjust the voltage. The operator can use the GSC keypad AC METER key to select which output load terminals to monitor for current and voltage measurements. The values and terminals are indicated on the upper and lower displays.

FUEL-FIRED HEATER SYSTEM (ISSUED TO SELECTED UNITS ONLY)

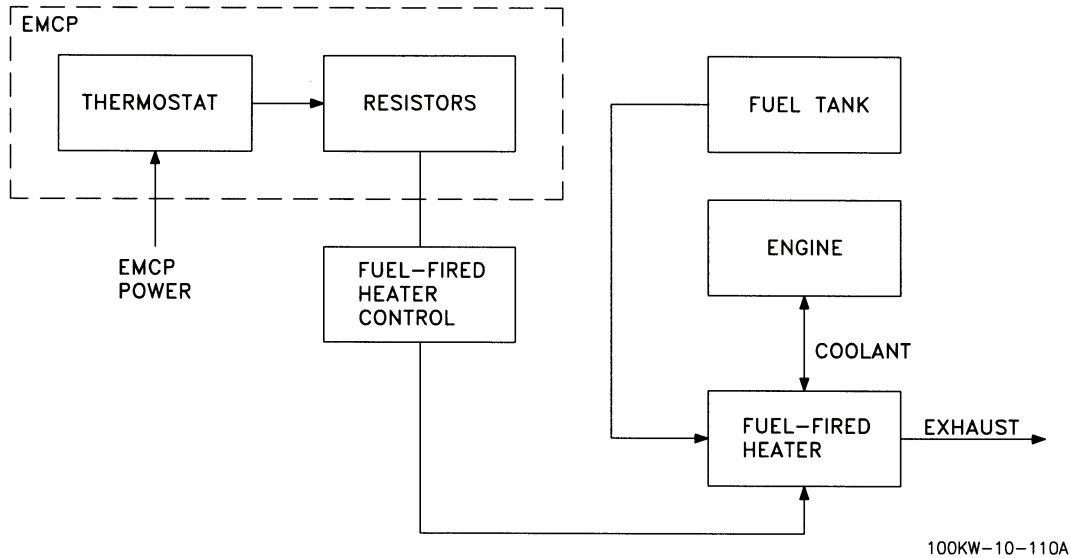

The winterization kit consists of a fuel-fired heater assembly with an internal water pump. The fuel-fired heater assembly preheats coolant and internal water pump circulates heated engine coolant through the engine. The fuel-fired heater system uses a 24 Vdc electric system that powers the heater fuel pump and circulating pump and a resistor circuit that warms EMCP components. The EMCP resistors are also automatically energized any time the GSC has power applied to it and the thermostat closes (temperature below -20°F (-29°C)).

100 kW TACTICAL QUIET GENERATOR SET

0004 00

SUPPORTING DATA FOR REPAIR PARTS, SPECIAL TOOLS, TMDE, AND SUPPORT EQUIPMENT

COMMON TOOLS AND TEST EQUIPMENT

For authorized common tools and equipment, refer to the Modified Table of Organization and Equipment (MTOE), Common Table of Allowances (CTA) 50-970, Expendable/Durable Items (Except: Medical, Class V, Repair Parts, and Heraldic Items), or Army Medical Department Expendable/Durable Items CTA 8-100, as applicable to your unit.

SPECIAL TOOLS, TMDE, AND SUPPORT EQUIPMENT

Special Tools; Test, Measure, and Diagnostic Equipment (TMDE); and support equipment are not authorized to operators. These are needed for unit and direct support maintenance. They are listed in the Repair Parts and Special Tools Lists (RPSTL) TM 9-6115-739-24P, and in the Maintenance Allocation Chart (MAC) TM 9-6115-729-24P.

REPAIR PARTS

Repair parts are listed in the RPSTL work packages in TM 9-6115-729-24P.

CHAPTER 2
OPERATOR INSTRUCTIONS
FOR
100 kW TACTICAL QUIET GENERATOR SET

CHAPTER 2

OPERATOR INSTRUCTIONS
FOR
100 kW TACTICAL QUIET GENERATOR SET

WORK PACKAGE INDEX

<u>Title</u>	<u>WP Sequence No.</u>
DESCRIPTION AND USE OF OPERATOR CONTROLS AND INDICATORS.....	0005 00
OPERATION UNDER USUAL CONDITIONS.....	0006 00
OPERATION UNDER UNUSUAL CONDITIONS.....	0007 00

**100 kW TACTICAL QUIET GENERATOR SET
DESCRIPTION AND USE OF OPERATOR CONTROLS AND INDICATORS**

0005 00

GENERAL

The following paragraphs contain references and illustrations that show the location and function of each control and indicator for operation of the TQG. Each control and indicator is clearly labeled as it appears on the equipment. Call-out numbers on the illustrations are keyed to the tabular listing which contains the name, based on the panel markings, and the functional description of each control and indicator.

ELECTRONIC MODULAR CONTROL PANEL

Table 1 describes the controls and indicators located on the TQG Electronic Modular Control Panel (EMCP). The EMCP includes the Generator Set Control (GSC) (1), Digital Voltage Regulator (DVR) (10), and alarm module (9). These three components are illustrated and described separately in this work package.

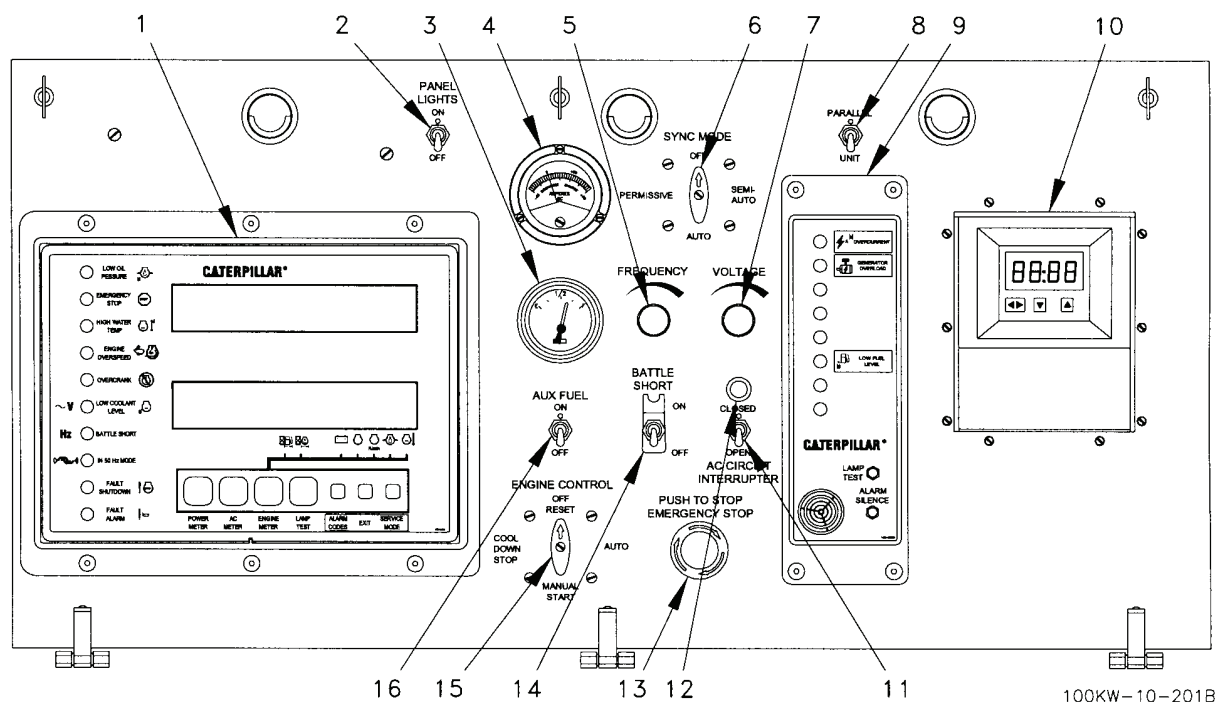

Table 1. Tactical Quiet Generator Electronic Modular Control Panel Controls and Indicators.

KEY	CONTROL OR INDICATOR	FUNCTION
1	GSC display module	GSC monitors generator operation and controls engine speed to maintain a constant 50 or 60 Hz output, regardless of load. Refer to Table 2 for controls and indicators.
2	PANEL LIGHTS ON OFF	Two-position toggle switch. Control panel lights are lit. Control panel lights are out.
3	Fuel level gauge	Indicates fuel level.

**100 kW TACTICAL QUIET GENERATOR SET
DESCRIPTION AND USE OF OPERATOR CONTROLS AND INDICATORS – Continued**

0005 00

ELECTRONIC MODULAR CONTROL PANEL – Continued

Table 1. Tactical Quiet Generator Electronic Modular Control Panel Controls and Indicators – Continued.

KEY	CONTROL OR INDICATOR	FUNCTION
4	DC AMMETER	Indicates DC current from engine alternator.
5	FREQUENCY adjust knob	Potentiometer permits adjustment of generator set frequency.
6	SYNC MODE switch OFF SEMI-AUTO AUTO PERMISSIVE	Four-position switch used to control TQG paralleling operations and modes. If not in paralleling mode, switch should be OFF. Disables synchronizing and synchroscope functions. With PARALLEL switch closed (up), GSC brings TQG in synchronization with load bus and holds it there indefinitely. AC CIRCUIT INTERRUPTER switch is enabled and operator can connect TQG to others. Automatic voltage matching is not enabled. Provides complete automatic paralleling with another unit. Bus Live: GSC brings TQG into sync with load bus and sends a signal to connect TQG to load bus. Bus Dead: GSC adjusts voltage to programmed value and connects output to load automatically. With PARALLEL switch closed (up), manual paralleling mode allows operator to adjust voltage, frequency, and phase of TQG to match load bus. When TQG is synchronized with bus, operator brings TQG on line by closing AC CIRCUIT INTERRUPTER switch.
7	VOLTAGE adjust knob	Potentiometer control permits fine adjustment of generator set voltage.
8	PARALLEL/UNIT switch PARALLEL UNIT	Two-position toggle switch. Controls dead bus monitoring and paralleling of load sharing modules. Activates paralleling circuits (up). Used when placing TQG in parallel mode. Bus is monitored by relays that will not allow generator output to be connected to load if there is power on load bus. Load sharing module is connected to paralleling cable connector for paralleling in ISOCHRONOUS mode. Deactivates paralleling circuits (down). Generator is operating independently of other generators. GSC monitors bus and load can be connected automatically or enabled for operator connection. Load sharing module is disconnected from paralleling cable connector output.
9	Alarm module	Alarm will sound if an overcurrent, an overload, or a low fuel condition exists. Refer to Table 3.
10	DVR	DVR provides excitation to control and regulate generator voltage. Refer to Table 4 for controls and indicators.

**100 kW TACTICAL QUIET GENERATOR SET
DESCRIPTION AND USE OF OPERATOR CONTROLS AND INDICATORS – Continued**

0005 00

ELECTRONIC MODULAR CONTROL PANEL – Continued

Table 1. Tactical Quiet Generator Electronic Modular Control Panel Controls and Indicators – Continued.

KEY	CONTROL OR INDICATOR	FUNCTION
11	AC CIRCUIT INTERRUPTER switch CLOSED Normal OPEN	Three-position toggle switch. Up momentary toggle activates circuits to close load contactor. Connects TQG to load. Press-to-test green indicator is lit when load contactor is closed. Toggle switch spring loaded to return to this position. Down momentary toggle activates circuits to open load contactor. Disconnects TQG from load. Press-to-test green indicator is off when load contactor is open.
12	Press-to-test green indicator	Indicator lights when AC CIRCUIT INTERRUPTER switch is set to CLOSED. Indicator off when AC CIRCUIT INTERRUPTER switch is set to OPEN.
13	PUSH TO STOP EMERGENCY STOP pushbutton switch	Press for emergency stop of TQG. Switch pulled out for normal operations. Switch can be reset by turning knob to right and pulling out.
14	BATTLE SHORT switch ON OFF	Two-position toggle switch. Hinged red safety cover must be raised to set to ON. Disables all safety or protective devices except short circuit and overspeed. Disables starting of engine. Yellow LED on GSC is lit. Normal operation of generator set. Lowering red cover returns switch to OFF.
15	ENGINE CONTROL switch OFF/RESET AUTO MANUAL START COOL DOWN/STOP	Four-position rotary switch. Engine shuts down and fault indicators and overload/short circuit module are reset, except in emergency stop while EMERGENCY STOP pushbutton is in. Allows remote start/stop control. Starts and runs generator set diesel engine. Shuts engine down after 5-minute cool down period has passed.
16	AUX FUEL switch ON OFF	Two-position switch controls auxiliary fuel pump. Turns on auxiliary fuel pump to supply fuel from external fuel supply. Only allows fuel to be consumed from generator set fuel tank.

**100 kW TACTICAL QUIET GENERATOR SET
DESCRIPTION AND USE OF OPERATOR CONTROLS AND INDICATORS – Continued**

0005 00

GENERATOR SET CONTROL

Table 2 describes the EMCP GSC indicator lights and light emitting diode (LED) displays.

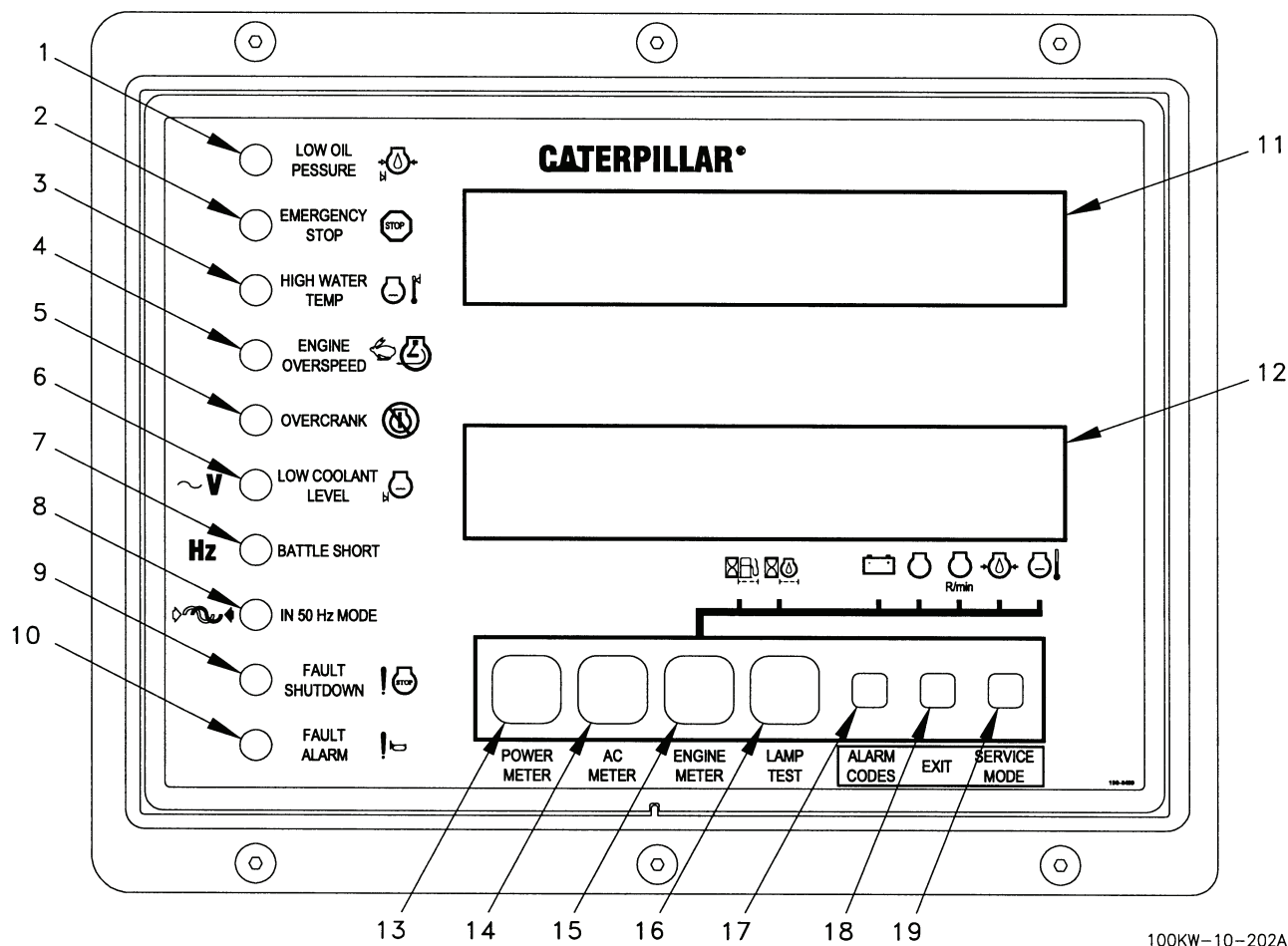



Table 2. Generator Set Control Controls and Indicators.

KEY	CONTROL OR INDICATOR	FUNCTION
1	LOW OIL PESSURE shutdown indicator	Red indicator flashes when oil pressure drops below the programmed low oil pressure setpoints. Engine shuts down and does not run until fault is corrected.
2	EMERGENCY STOP shutdown indicator	Red indicator flashes when PUSH TO STOP EMERGENCY STOP pushbutton is pressed in on control panel. Engine shuts down and does not start until pushbutton is pulled out and ENGINE CONTROL switch is set to OFF/RESET and back to AUTO or MANUAL START. PUSH TO STOP EMERGENCY STOP pushbutton switch can be reset by turning knob to right or pulling out.
3	HIGH WATER TEMP shutdown indicator	Red indicator flashes when engine coolant temperature rises above programmed setpoint for high coolant temperature shutdown. Engine shuts down and does not start until fault is corrected.

GENERATOR SET CONTROL – Continued

Table 2. Generator Set Control Controls and Indicators – Continued.

KEY	CONTROL OR INDICATOR	FUNCTION
4	ENGINE OVERSPEED shutdown indicator	Red indicator flashes when engine speed rises above programmed setpoint for engine overspeed. Engine shuts down and does not start until fault is corrected.
5	OVERCRANK shutdown indicator	Red indicator flashes when engine does not start within programmed setpoint for total cycle crank time. Engine not allowed to start until fault is corrected.
		NOTE
		Indicator lights (key 6 thru 8) perform <u>dual functions</u> depending on the position of the UNIT/PARALLEL switch.
		When UNIT/PARALLEL switch is set to UNIT (FUNCTION I), the indicators display the following:
	FUNCTION I	
6	LOW COOLANT LEVEL indicator	Yellow light flashes when coolant level drops below probe of coolant loss sensor. Engine shuts down and does not start until fault is corrected.
7	BATTLE SHORT indicator	Yellow indicator lights when BATTLE SHORT switch is set to ON. Indicates TQG is operating in battle short condition.
8	IN 50 Hz MODE	Yellow indicator lights when TQG is in 50 Hz mode.
		NOTE
		When UNIT/PARALLEL switch is set to PARALLEL (FUNCTION II), the indicators display the following:
	FUNCTION II	
6	~ V (left side of light)	Yellow indicator flashes in paralleling mode until TQG and paralleling bus voltages are within acceptable limits. Yellow indicator lights when voltages match.
7	HZ (left side of light)	Yellow indicator flashes in paralleling mode until TQG and paralleling bus frequencies are within acceptable limits. Yellow indicator lights when frequencies match.
8	 (left side of light)	Yellow indicator flashes in paralleling mode until TQG and paralleling bus phases are within acceptable limits. Yellow indicator lights when phases match.
9	FAULT SHUTDOWN indicator	Red indicator flashes when GSC detects a fault that is a shutdown fault. If engine is running, it is shut down. The engine will not start. A diagnostic code is displayed on upper GSC display (11). Diagnostic codes are described in Chapter 3, Troubleshooting.
10	FAULT ALARM indicator	Yellow light flashes when GSC detects an alarm fault. Alarm fault does not cause engine status to change and engine will continue to run. If engine was not started, it may be started. A diagnostic code is displayed on upper GSC display (11) when ALARM CODES key (17) at bottom of GSC is pressed. Diagnostic codes are described in Chapter 3, Troubleshooting.

GENERATOR SET CONTROL – Continued

Table 2. Generator Set Control Controls and Indicators – Continued.

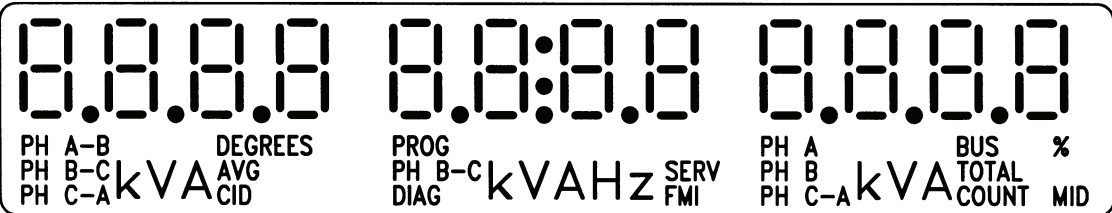
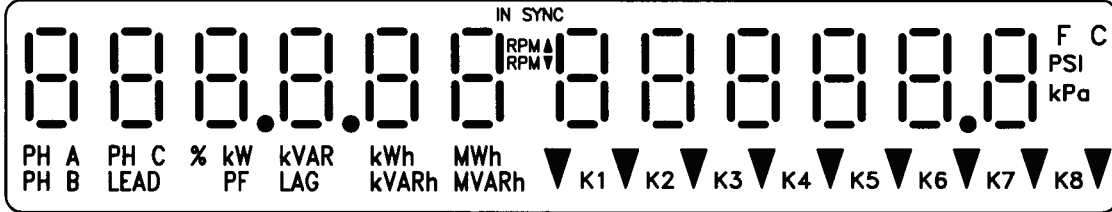
KEY	CONTROL OR INDICATOR	FUNCTION
		<p style="text-align: right;">100KW-10-203</p> <p>11 Upper display (Normal Operation) Shows AC voltage, current, and frequency of one phase of generator output. Each phase can be viewed one at a time by pushing AC METER key (14) at bottom of GSC. Upper display also displays diagnostic codes for system faults. Refer to Keypad descriptions (13 thru 19) for more information.</p> <p style="text-align: center;">NOTE</p> <p style="text-align: center;">Active during paralleling only.</p> <p>Upper display (Synchroscope for Parallel Operation) In paralleling modes, upper display toggles between bus and incoming generator phase C-A voltage and frequency. Right side display shows bUS or GEN. Pressing AC METER key (14) stops cycle.</p>
12	Lower display (Normal Operation)	 <p style="text-align: right;">100KW-10-204A</p> <p>When POWER METER key (13) is pressed, displays values for power metering.</p> <p>When ENGINE METER key (15) is pressed, displays system battery voltage, engine hours, engine speed, engine oil pressure, and engine coolant temperature. Each value is shown for two seconds. A small pointer that lines up with the icon for the condition indicates the value shown. Refer to Keypad descriptions (13 thru 19) for more information.</p>

GENERATOR SET CONTROL – Continued

Table 2. Generator Set Control Controls and Indicators – Continued.

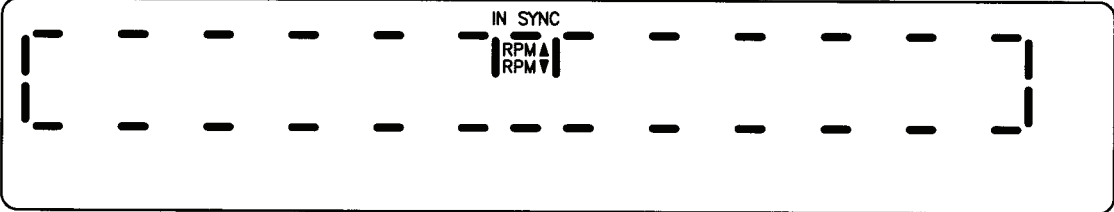
KEY	CONTROL OR INDICATOR	FUNCTION
<p>NOTE</p> <p>Active during paralleling only.</p>  <p style="text-align: right;">100KW-10-230</p>		
	<p>Lower display (Synchroscope for Parallel Operation)</p> <p><input type="checkbox"/> Rotating clockwise</p> <p><input type="checkbox"/> Rotating counterclockwise</p> <p><input type="checkbox"/> Stopped in any position other than top center</p> <p>IN SYNC</p> <p><input type="checkbox"/> Stopped at top center</p>	<p>During paralleling operations, lower display operates as synchroscope in SEMI AUTO and PERMISSIVE settings of SYNC MODE switch (6). A square symbol revolves around perimeter of display to indicate phase angle and frequency relationships between bus and incoming generator. Yellow indicator lights for three fault alarms also show status of paralleling. Synchronizing lights indicate that voltages match $\sim V$ (6), that frequencies are matched HZ (7), and that phases are matched $\square \sim \blacksquare$ (8). Indicator lights flash speed is relative to speed of synchroscope symbol.</p> <p>Frequency of incoming generator is greater than load bus.</p> <p>Frequency of incoming generator is less than load bus.</p> <p>Frequency of incoming generator and load bus are the same. Phases are different.</p> <p>Frequency of incoming generator and load bus are the same. In phase (phase angle is 0°).</p>

GENERATOR SET CONTROL – Continued

Table 2. Generator Set Control Controls and Indicators – Continued.

KEY	CONTROL OR INDICATOR	FUNCTION
13-19 13	Keypad POWER METER	<p>Used to control information shown on upper display and lower display.</p> <p>Displays power data to lower display. When pressed, following functions scroll automatically:</p> <ul style="list-style-type: none"> Total real power (kW) Total reactive power (KVAR) Percentage of rated power (%kW) Power factor (average) (PF) <p>Display scrolling stops when operator presses key for less than 5 seconds. Display will show a particular parameter continuously.</p> <p>Additional functions will scroll if key held for more than 5 seconds:</p> <ul style="list-style-type: none"> Total real power (kW) Real power phase A (kW) Real power phase B (kW) Real power phase C (kW) Total apparent power (kVA) Total reactive power (KVA) Percentage of rated power (%kW) Power factor (average) (PF) Power factor phase A Power factor phase B Power factor phase C Total energy output (kWh) Total reactive energy output (kVARHr)
14	AC METER	<p>Selects phase of generator output that is shown on upper display. Pressing this key allows operator to check voltage, current, and frequency of each phase one at a time. Options are as follows:</p> <ul style="list-style-type: none"> Voltage (average), frequency, current (total) Voltage (line to line), frequency, current (line) for any one phase Voltage (line to line) for all three phases at once Current (line) for all three phases at once Voltage (line to neutral) for all three phases at once

GENERATOR SET CONTROL – Continued

Table 2. Generator Set Control Controls and Indicators – Continued.

KEY	CONTROL OR INDICATOR	FUNCTION
15	ENGINE METER	<p>Stops scrolling of engine condition data shown on lower display. Pointer flashes to indicate that scrolling is stopped. Pressing key again resumes scrolling. Sequence of reported data is as follows:</p> <ul style="list-style-type: none"> Fuel filter run hours Oil filter run hours Battery voltage Engine run hours Engine rpm Engine oil pressure Engine coolant temperature
16	LAMP TEST	<p>Performs lamp test on GSC. Eight fault indicators are on continuously and all segments of upper display and lower display are on.</p>
17	ALARM CODES	<p>If FAULT ALARM light is flashing, pressing this key displays diagnostic code (WP 0009 00) in upper display. Pressing key again resumes display of generator output information. If FAULT ALARM light is off, this key has no function.</p>
18	EXIT	<p>Service Mode. FOR MAINTENANCE PERSONNEL USE ONLY.</p>
19	SERVICE MODE	<p>Service Mode. FOR MAINTENANCE PERSONNEL USE ONLY.</p>

ALARM MODULE

Table 3 describes the EMCP alarm module controls and indicators.

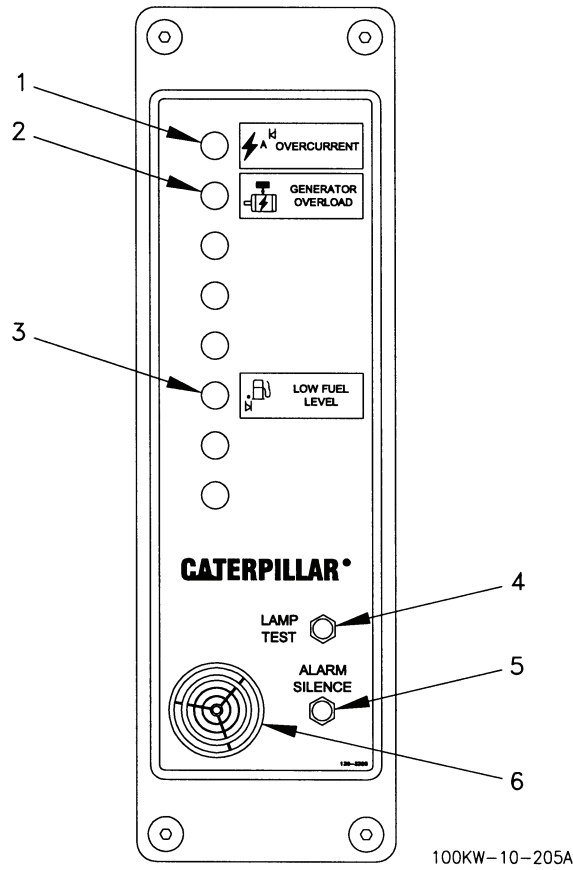
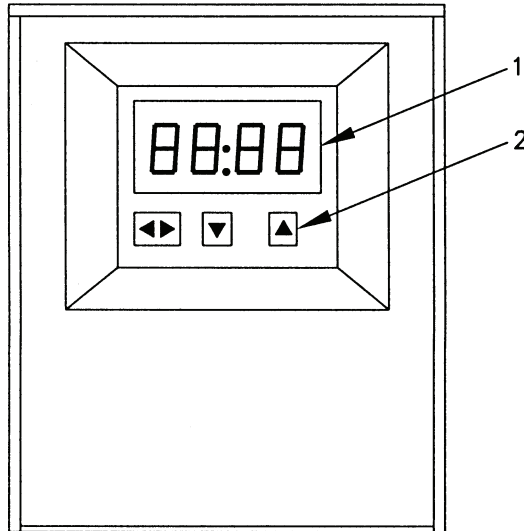

Table 3. Alarm Module Controls and Indicators.

KEY	CONTROL OR INDICATOR	FUNCTION
1	OVERCURRENT indicator	Amber light flashes to indicate overcurrent condition. Generator is immediately disconnected from load.
2	GENERATOR OVERLOAD indicator	Amber light flashes to indicate generator overload condition. Generator is immediately disconnected from load.
3	LOW FUEL LEVEL indicator	Red light glows steady to indicate low fuel level. Engine will immediately shut down.
4	LAMP TEST	Press-to-test button lights indicator lamps. LAMP TEST also resets overload/short circuit module.
5	ALARM SILENCE	Pushbutton silences alarm horn.
6	Alarm horn	When LOW FUEL LEVEL red light glows steady, alarm horn will sound until ALARM SILENCE pushbutton switch is pushed.



DIGITAL VOLTAGE REGULATOR

Table 4 describes the EMCP DVR module controls and indicators. DVR is a module that displays 3-digit DVR fault codes (WP 0009 00). Operator can only record the alarm codes and notify maintenance when DVR Fault Codes are displayed. Operators are not authorized to use this control to change TQG settings.



100KW-10-206

Table 4. Digital Voltage Regulator Controls and Indicators.

KEY	CONTROL OR INDICATOR	FUNCTION
1	Display area	Displays three-digit DVR fault codes (WP 0009 00). Also displays numbers representing different parameters of DVR system. Display and keypad are used to select and manipulate parameter values that control operation of DVR. Colon indicates that number is a parameter code. If colon is not present, the number is a parameter value.
2	Keypad	Used to change information shown on display. FOR MAINTENANCE PERSONNEL USE ONLY.
		Function key used to toggle between parameter code and parameter value for the code and to enter new code or value into DVR memory.
		Scroll down key is used to move down to previous parameter code or decrease value.
		Scroll up key is used to move up to next parameter code or increase value.

**100 kW TACTICAL QUIET GENERATOR SET
DESCRIPTION AND USE OF OPERATOR CONTROLS AND INDICATORS – Continued**

0005 00

RESISTOR ASSEMBLY A7

Table 5 describes controls located on resistor assembly A7. Resistor assembly A7 is located inside the control box assembly behind the EMCP.

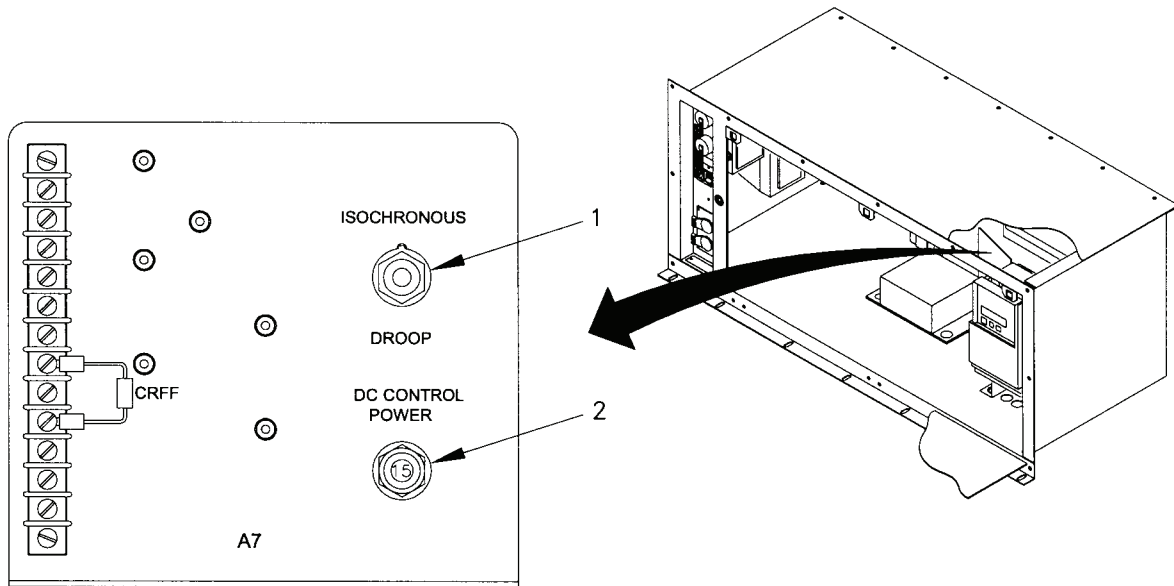

100KW-10-207A

Table 5. Resistor Assembly A7 Controls.

KEY	CONTROL OR INDICATOR	FUNCTION
1	ISOCHRONOUS/DROOP switch	Two-position switch. Used for frequency stabilization circuits and TQG paralleling functions.
	ISOCHRONOUS	Up position used for generator constant 50/60 Hz operation.
	DROOP	Down position will accommodate fluctuations for under load conditions.
2	DC CONTROL POWER	When pushed in, circuit breaker supplies 24 Vdc power to GSC.

DEAD CRANK SWITCH

Table 6 describes DEAD CRANK SWITCH functions. The dead crank switch is located inside the housing. Access is through the rear left side housing door.

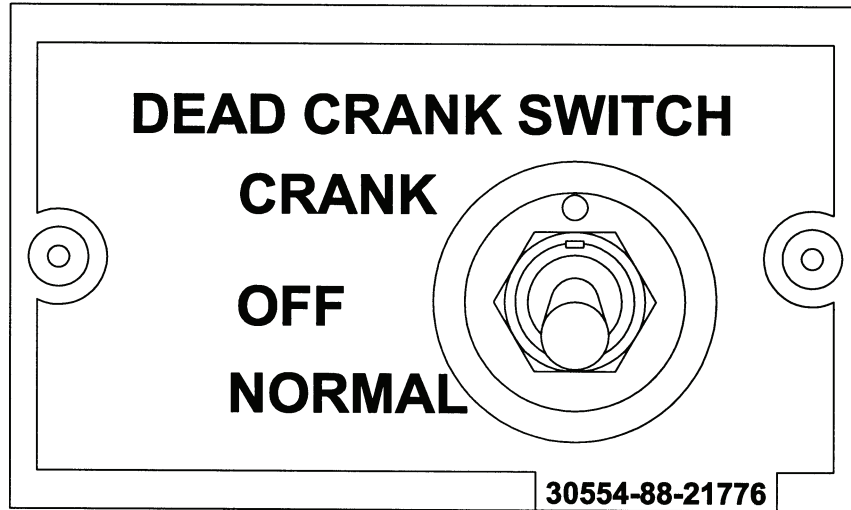

100KW-10-208

Table 6. Dead Crank Switch Control.

CONTROL OR INDICATOR	FUNCTION
CRANK	Energizes starter motor to crank engine for service and maintenance purposes. Engine will not start.
OFF	Center position removes power from GSC, DVR, and Engine Control Module (ECM). Engine will not crank or start.
NORMAL	Supplies power to GSC, DVR, and ECM, allowing normal operation of generator starting controls and circuits.

PARALLELING RECEPTACLES PANEL

Table 7 describes the controls and indicators of the paralleling receptacles panel.

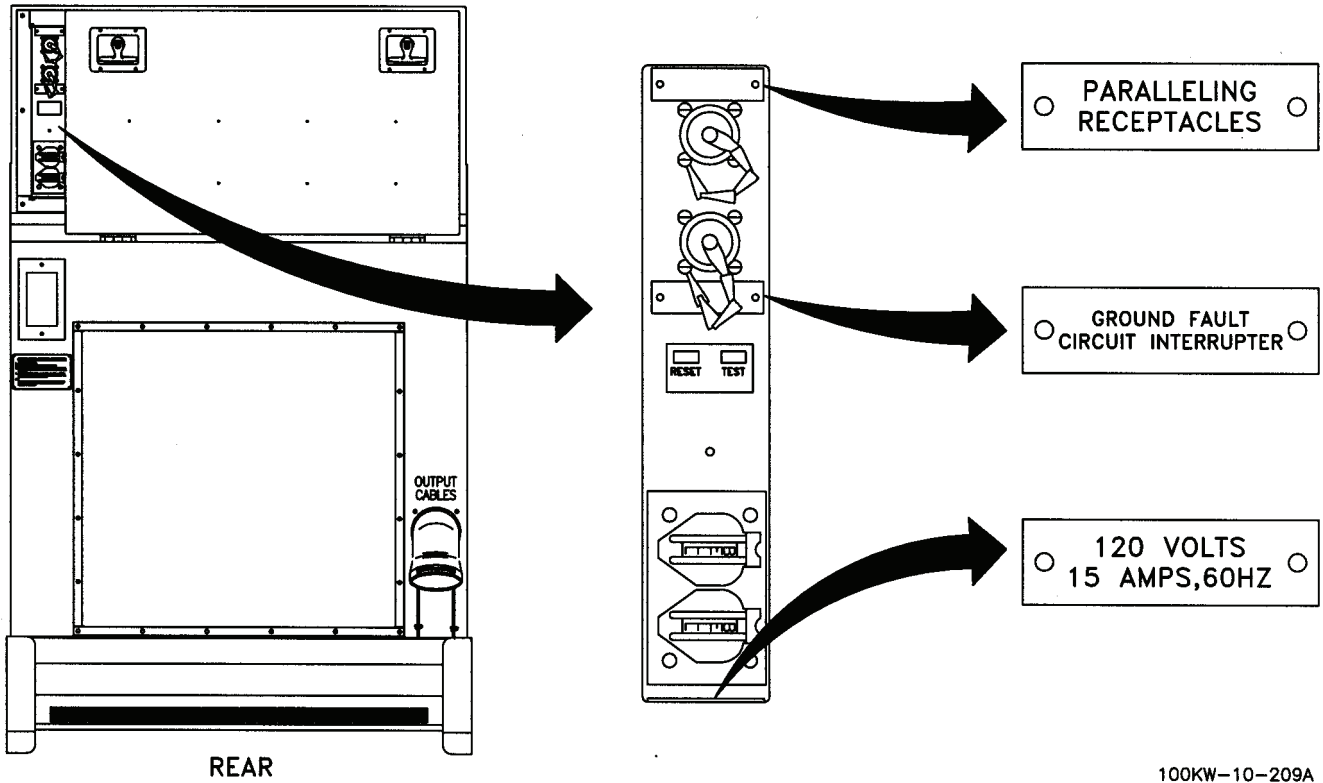
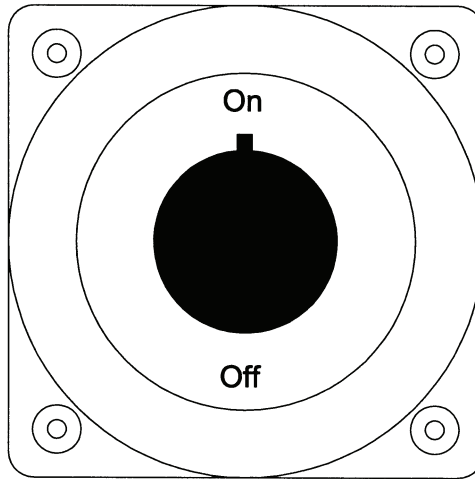

Table 7. Paralleling Receptacles Panel Controls and Indicators.

CONTROL OR INDICATOR	FUNCTION
PARALLELING RECEPTACLES	Two five-pin receptacles for connecting TQG sets for parallel operation.
GROUND FAULT CIRCUIT INTERRUPTER circuit breaker	Provides ground fault and circuit breaker protection for two 120 Vac utility outlets.
TEST	Pushbutton allows testing of GFCI circuit breaker.
RESET	Pushbutton resets GFCI circuit breaker TEST.
Convenience receptacles	Two convenience receptacles provide 120 Vac, 60 Hz, 15A power for external use. Frequency of output will be same as generator output frequency.

BATTERY DISCONNECT SWITCH

Table 8 describes the positions and functions of the Battery Disconnect Switch located inside the battery storage compartment at front of generator set.



100KW-10-210A

Table 8. Battery Disconnect Switch Controls.

CONTROL OR INDICATOR	FUNCTION
<p>ON</p> <p>OFF</p>	<p style="text-align: center;"><u>WARNING</u></p> <p>DC voltages are present at generator set electrical components even with generator set shut down. Avoid shorting any positive with ground/negative. Failure to comply can cause injury to personnel and damage to equipment.</p> <p>NATO slave receptacle has 24-Vdc even when disconnect switch is set to OFF.</p> <p>Connects batteries to generator set.</p> <p>Disconnects batteries from generator set.</p>

RECONNECTION BOARD TB1

OPERATORS ARE NOT AUTHORIZED TO REPOSITION THIS BOARD. Table 9 describes the Reconnection Board TB1 located at right rear upper left of generator set (WP 0002 00, Figure 1, sheet 2).

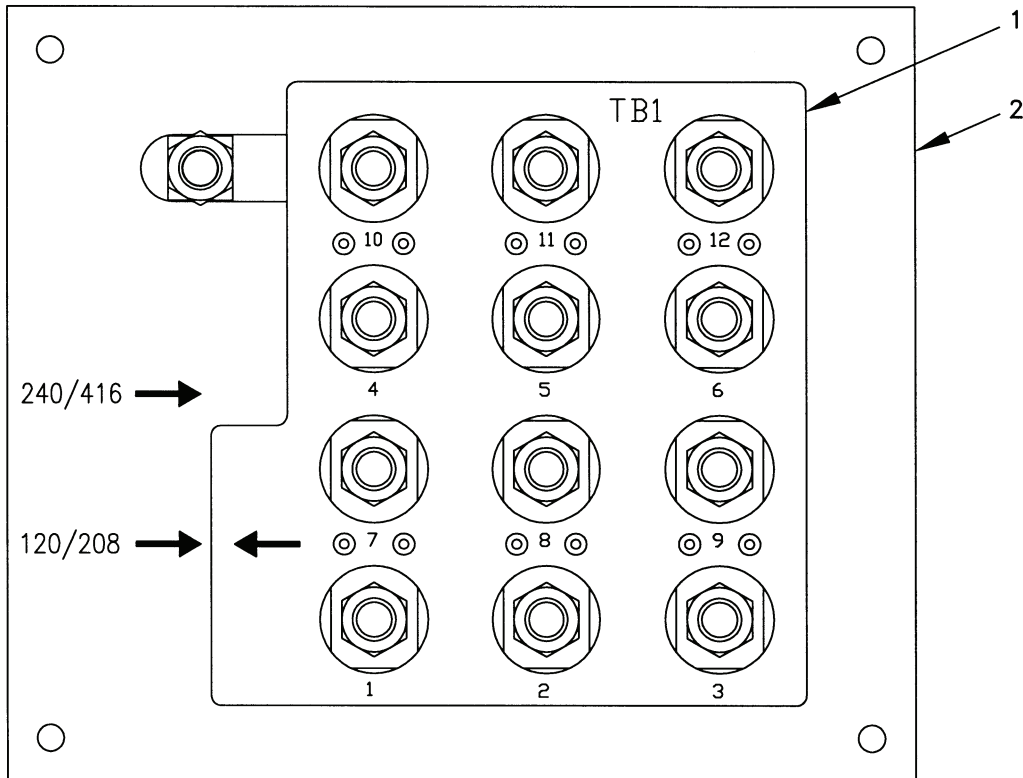

100KW-10-211

Table 9. Reconnection Board TB1.

KEY	CONTROL OR INDICATOR	FUNCTION
1	TB1	Reconnection board top plate can be positioned to provide 120/208 Vac, 3-phase, or 240/416 Vac, 3-phase, power output from TQG set. Aligned arrows determine output.
2	Reconnection board base	Contains 12 connector lugs for $\Phi A, \Phi B, \Phi C$, and neutral legs (L1, L2, L3, N or GND) for 3-phase power output. Voltage output is for three-phase power.
	120/208	Setting for 120/208 Vac, 3-phase, power output. Each phase is nominal 120 Vac to ground and 208 Vac between any two phases.
	240/416	Setting for 240/416 Vac, 3-phase, power output. Each phase is nominal 240 Vac to ground and 416 Vac between any two phases.

OUTPUT LOAD TERMINAL BOARD TB2

Table 10 describes the Output Load Terminal Board TB2 connections located at lower right rear of generator set.

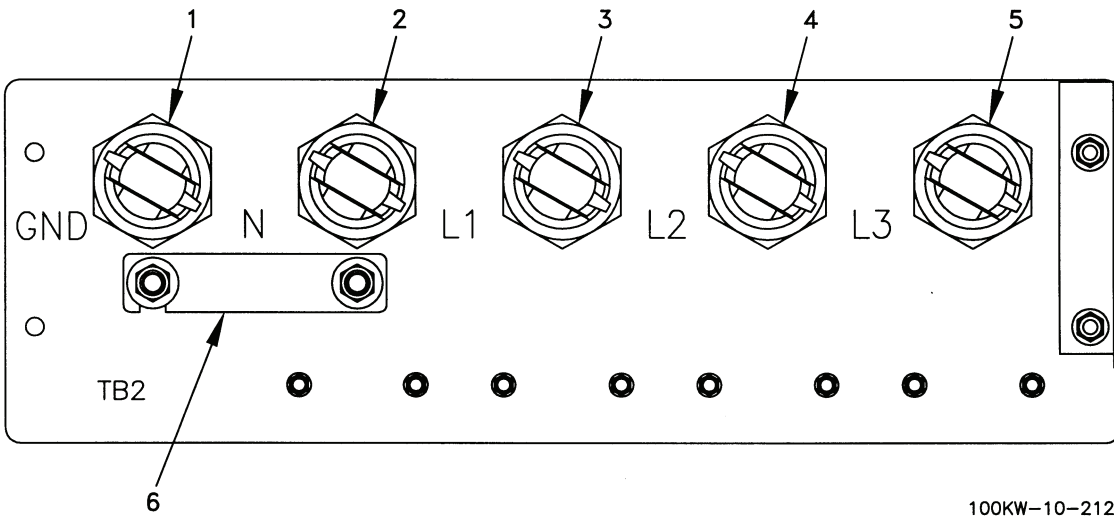

100KW-10-212A

Table 10. Output Load Terminal Board TB2 Connections.

KEY	CONTROL OR INDICATOR	FUNCTION
1	GND	Ground lug. Used with catch plate and post for multiple grounding connections.
2	N	Neutral line for generator output loads.
3	L1	Connection for L1 (Φ A) leg of three-phase output power.
4	L2	Connection for L2 (Φ B) leg of three-phase output power.
5	L3	Connection for L3 (Φ C) leg of three-phase output power.
6	Jumper	Remove during 5-wire operations.

FUEL-FIRED HEATER CONTROL PANEL (ISSUED TO SELECTED UNITS ONLY)

Table 11 describes the fuel-fired heater control panel (winterization kit) controls and indicators located on left rear of generator set.

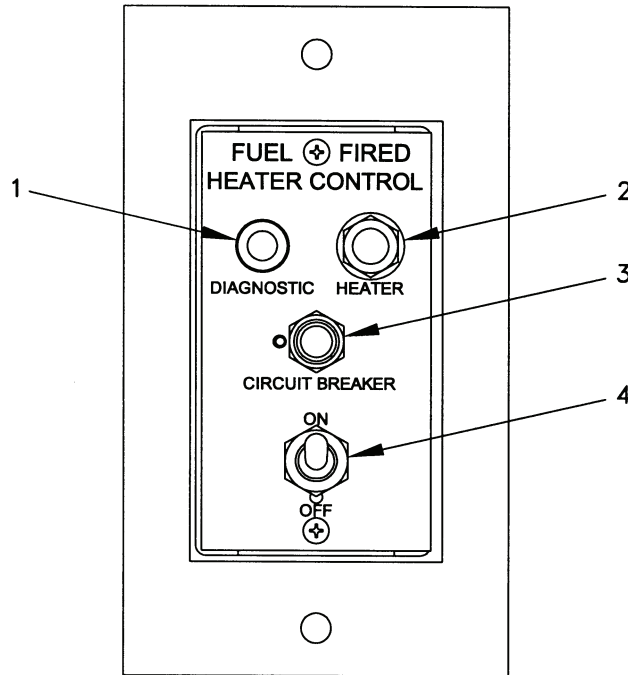

100KW-10-213

Table 11. Fuel-Fired Heater Control Panel (Winterization Kit) Controls and Indicators.

KEY	CONTROL OR INDICATOR	FUNCTION
1	DIAGNOSTIC indicator	Red lamp lights upon fuel-fired heater failure or winterization kit malfunction.
2	HEATER indicator	Amber press-to-test lamp lights when fuel-fired heater is operating.
3	CIRCUIT BREAKER	Fused 15A circuit breaker for fuel-fired heater control circuit. Applies 24 Vdc to fuel-fired heater.
4	Circuit switch	Two-position toggle switch activates or deactivates winterization kit circuits.
	ON	Energizes fuel-fired heater for coolant heating and applies 24 Vdc to EMCP resistors.
	OFF	Deenergizes fuel-fired heater and EMCP resistors.

**100 kW TACTICAL QUIET GENERATOR SET
OPERATION UNDER USUAL CONDITIONS**

0006 00

THIS WORK PACKAGE COVERS:

- Siting Requirements
- Shelter Requirements
- Assembly and Preparation for Use
- Initial Adjustments Before Use and Self-Test
- NATO Slave Receptacle Start Operation
- Operating Procedures
- Emergency Stopping
- Parallel Unit Operation (Load Sharing)
- Decals and Instruction Plates
- Operating Auxiliary Equipment
- Preparation for Movement

INITIAL SETUP:

Maintenance Level

Operator

Tools and Special Tools

None

Personnel Required

One

References

- WP 0012 00
- WP 0016 00
- DA Form 5988-E
- DA PAM 738-750
- DD Form 314
- SF Form 361
- SF Form 368
- TM 9-2330-376-14&P
- TM 9-6115-729-24

Materials/Parts

None

SITING REQUIREMENTS

Select a site that provides or has the following features:

- Ample space for maneuvering vehicles that may be used to move trailer-mounted generator set.
- Firm, reasonably level; well-drained terrain.
- Not adjacent to low areas where exhaust fumes might collect.

SHELTER REQUIREMENTS

Under normal operating conditions, the generator set does not require a shelter.

ASSEMBLY AND PREPARATION FOR USE

1. Notify maintenance to uncrate, unpack the equipment if applicable.
2. Notify maintenance to inspect equipment for possible damage incurred during shipment. If equipment has been damaged, report damage on SF Form 361, Transportation Deficiency Report.
3. Notify maintenance to check equipment against packing slip to see if shipment is complete. Report all differences using procedure given in DA PAM 738-750.
4. Notify maintenance to perform Preventive Maintenance Checks and Services (PMCS) (see TM 9-6115-729-24).
5. If required, notify maintenance to reposition Reconnection Board and reprogram DVR for specified voltage and frequency and reprogram the GSC set points as determined by the mission.

**100 kW TACTICAL QUIET GENERATOR SET
OPERATION UNDER USUAL CONDITIONS – Continued**

ASSEMBLY AND PREPARATION FOR USE – Continued

6. (Army and Air Force) Schedule next PMCS on DD Form 314, Preventive Maintenance Schedule and Record. Marine Corps use NAVMC 10524, Consolidated Engineer Equipment Operations Log and Service Record to indicate the next scheduled PMCS.
7. (Army) Report all deficiencies on DA Form 5988-E, Automated form in the Unit Level Logistics System (ULLS), Equipment Inspection and Maintenance Worksheet, including deficiencies that appear to involve unsatisfactory design. When no automation is available, use DA Form 2404 (Equipment Maintenance and Inspection Worksheet). Both forms serve the same purpose. Air Force and Marine Corps report all deficiencies on SF Form 368.
8. (Army and Air Force) Operator perform PMCS (WP 0012 00). Marine Corps uses NAVMC 10560 to record all PMCS work.

Setting Up Trailer-Mounted Tactical Quiet Generator Set

1. If TQG set is trailer-mounted, level trailer per procedures in TM 9-2330-376-14&P.
2. If TQG is to be installed or it must be removed from XM1061E1 trailer, notify maintenance.
3. Perform trailer PMCS per TM 9-2330-376-14&P.

Installation of Ground Rod



Metal jewelry can conduct electricity and become entangled in generator set components. Remove all metal jewelry when working on generator set. Failure to comply can cause injury or death to personnel.

High voltage is produced when the generator set is in operation. Never attempt to start the generator set unless it is properly grounded. Failure to comply can cause injury or death to personnel.

DC voltages are present at generator set electrical components even with generator set shut down. Avoid shorting any positive with ground/negative. Failure to comply can cause injury to personnel and damage to equipment.

NOTE

The following installation is for skid-mounted TQG and trailer-mounted TQG. For the trailer-mounted TQG the ground cable is connected between the TQG and a terminal on the trailer and then connected to the ground rod.

1. Remove three ground rods (1) from storage inside left front housing door.
2. Remove ground cable (2), clamp (3), driving stud (4), and three couplers (5) from storage inside front battery compartment.
3. Open door to output load terminal board TB2 (6) on right rear of generator housing and remove terminal nut wrench (7).
4. Route ground cable (2) from outside to inside of housing through OUTPUT CABLES boot (8).

**100 kW TACTICAL QUIET GENERATOR SET
OPERATION UNDER USUAL CONDITIONS – Continued**

ASSEMBLY AND PREPARATION FOR USE – Continued**Installation of Ground Rod – Continued**

5. Insert ground cable (2) through slot on output load terminal board terminal marked GND (9).
6. Tighten nut on GND terminal (9) with wrench (7).

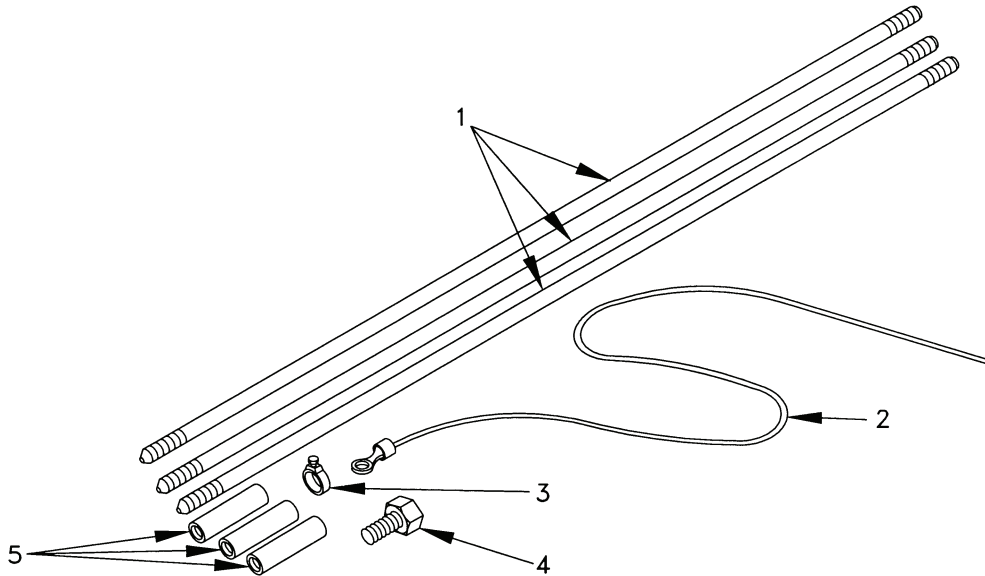

100KW-10-214A

7. Connect coupler (5) to ground rod (1) and screw driving stud (4) into coupler (5). Make sure that driving stud is screwed completely into coupler and contacts top of ground rod.
8. Drive ground rod into ground until coupler is just above surface.
9. Remove driving stud and install another section of ground rod into coupler.
10. Repeat steps 7, 8, and 9 until ground rod has been driven 8 feet or deeper. Drive ground rod down until last coupler is just above ground surface.
11. Remove coupler (5) and driving stud (4) and return to storage inside front battery compartment door.

Installation of Ground Rod – Continued

12. Insert ground cable (2) through clamp (3) and slide clamp on last ground rod section (1). Tighten clamp and ground cable.

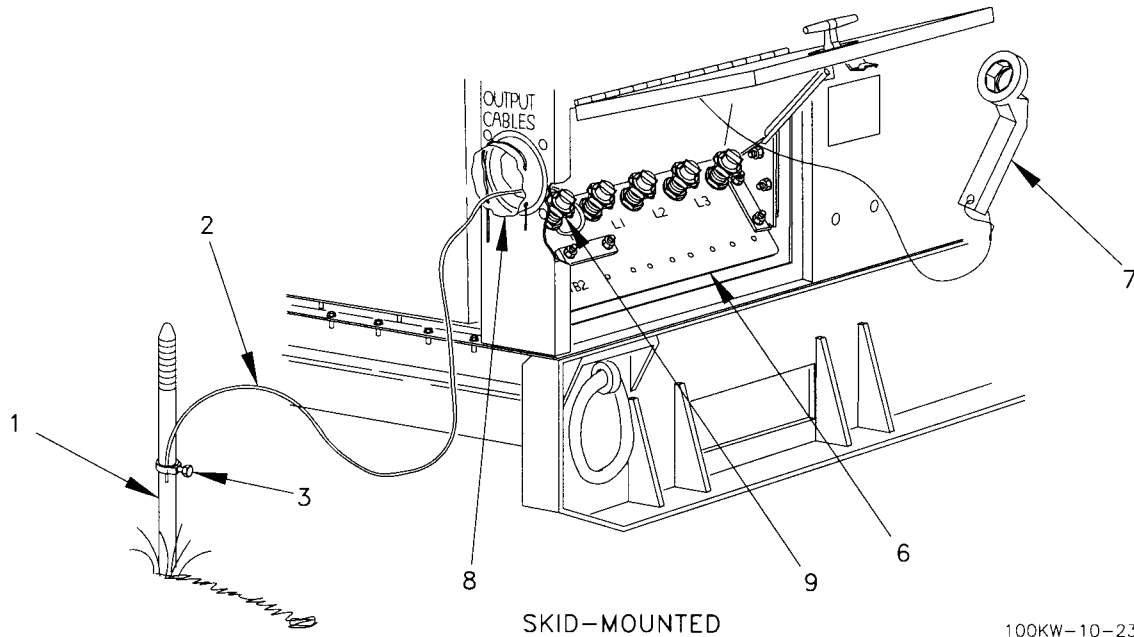

13. If TQG is trailer-mounted configuration PU-807A, insert ground cable (2) through terminal (10) on end of XM1061E1 trailer (11).

ASSEMBLY AND PREPARATION FOR USE – Continued

Installation of Ground Rod – Continued

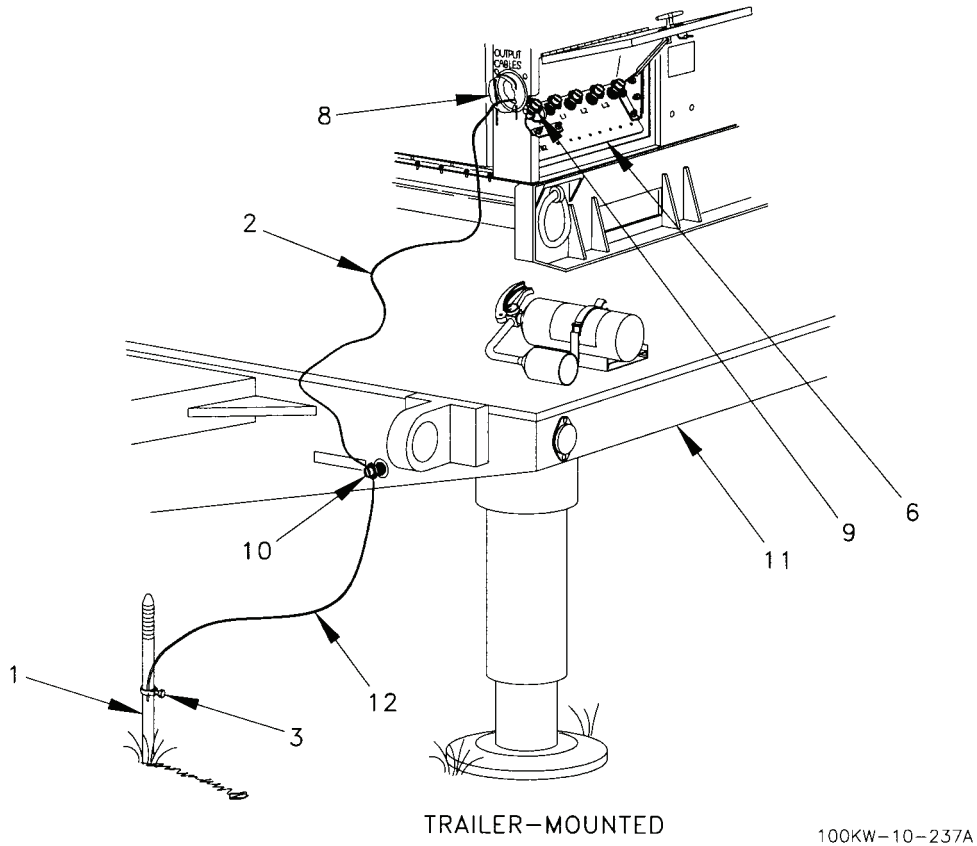

14. Insert trailer ground cable (12) through terminal (10) on end of XM1061E1 trailer (11) with TQG ground cable (2) and tighten nut.
15. Insert trailer ground cable (12) through clamp (3) and slide clamp on last ground rod section (1). Tighten clamp and ground cable.

**100 kW TACTICAL QUIET GENERATOR SET
OPERATION UNDER USUAL CONDITIONS – Continued
ASSEMBLY AND PREPARATION FOR USE – Continued**

Installation of Load Cables

WARNING



High voltage is produced when this generator set is in operation. Make sure unit is completely shut down and free of any power source before attempting any repair or maintenance on the unit. Failure to comply can cause injury or death to personnel.

High voltage is produced when the generator set is in operation. Never attempt to connect or disconnect load cables while the generator set is running. Failure to comply can cause injury or death to personnel.

WARNING

A qualified technician must make the power connections and perform all continuity checks. The power source may be a generator or commercial power. Failure to comply with this warning can result in injury or death to personnel.

CAUTION

When using single phase connections, balance loads between terminals. Do not connect all loads between one terminal and N. Failure to observe this caution can result in damage to equipment.

1. On Electronic Modular Control Panel (EMCP), set ENGINE CONTROL switch to OFF/RESET (WP 0005 00-1).
2. Perform all BEFORE PMCS requirements per WP 0012 00.
3. Open rear left housing door and set DEAD CRANK SWITCH to OFF (WP 0005 00-13).
4. Open battery compartment and set Battery Disconnect Switch to OFF (WP 0005 00-15).
5. Select required output terminals from Table 1.
6. Open output load terminal door on rear right of housing.
7. Using terminal nut wrench (7) loosen terminal nuts (13) on output load terminals (14) selected in step 5.
8. Insert ends of load cables (15) through OUTPUT CABLES boot (8). Insert ends of cables into slots of output load terminals (14).
9. Tighten load terminal nuts (13) using terminal nut wrench (7).
10. Secure wrench (7) inside load terminal board door and close door.

ASSEMBLY AND PREPARATION FOR USE – Continued

Installation of Load Cables – Continued

Table 1. Load Terminal and AC Reconnection Board.

LOAD VOLTAGE	RECONNECTION BOARD POSITION	LOAD BOARD TERMINALS
120 Vac single phase 120 Vac single phase 120 Vac single phase	120/208	L1 to N, L2 to N, or L3 to N (Single phase loads can be connected between any terminal and N.)
208 Vac 3-phase 208 Vac 3-phase 208 Vac 3-phase	120/208	L1, L2, L3, and N
240 Vac single phase 240 Vac single phase 240 Vac single phase	240/416	L1 to N, L2 to N, or L3 to N (Single phase loads can be connected between any terminal and N.)
416 Vac 3-phase 416 Vac 3-phase 416 Vac 3-phase	240/416	L1, L2, L3, and N

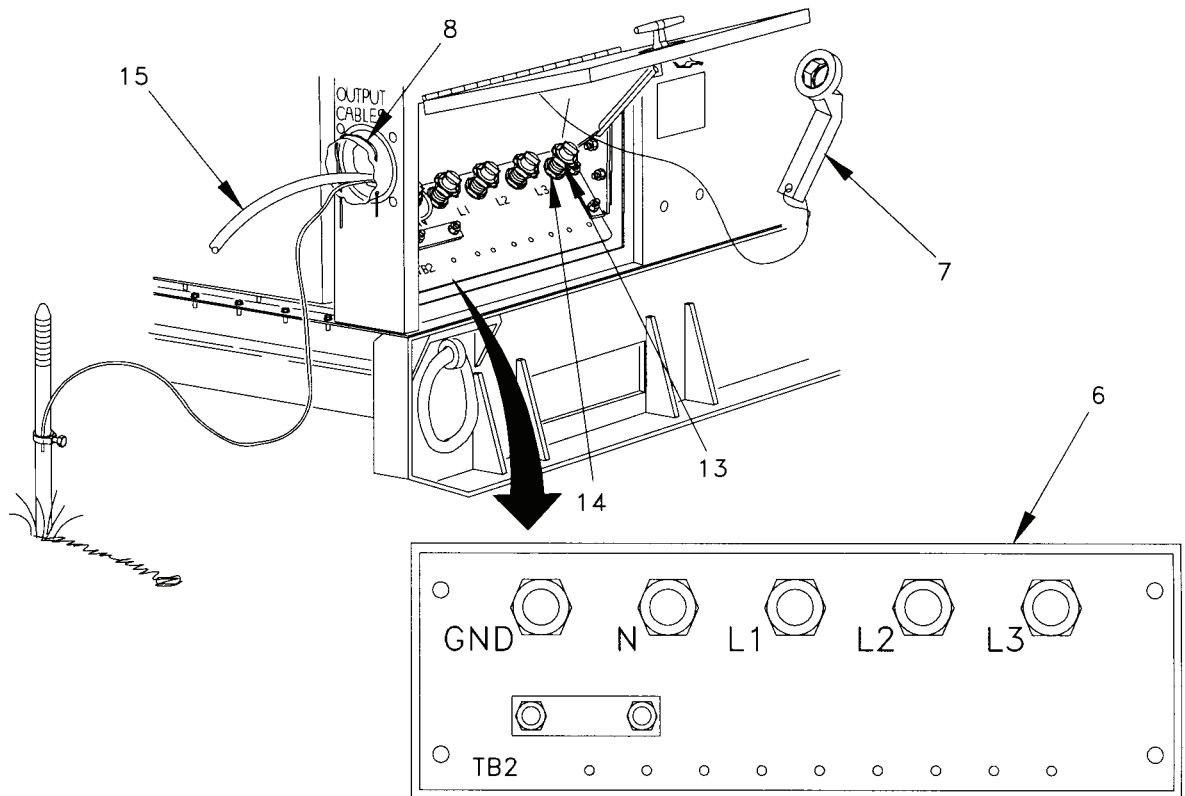

**100 kW TACTICAL QUIET GENERATOR SET
OPERATION UNDER USUAL CONDITIONS – Continued
ASSEMBLY AND PREPARATION FOR USE – Continued**

0006 00

Connecting Auxiliary Fuel Hose

WARNING

Metal jewelry can conduct electricity and become entangled in generator set components. Remove all metal jewelry when working on generator set. Failure to comply can cause injury or death to personnel.

WARNING



Diesel fuel is flammable and toxic to eyes, skin, and respiratory tract. Skin and eye protection are required when working in contact with diesel fuel. Avoid repeated or prolonged contact. Provide adequate ventilation. Operators are to wash exposed skin and change chemical soaked clothing promptly if exposed to fuel. Failure to comply can cause injury or death to personnel.

Fuels used in the generator set are flammable. When filling the fuel tank, maintain metal-to-metal contact between filler nozzle and fuel tank opening to eliminate static electrical discharge. Failure to comply can result in flames and possible explosion and can cause injury or death to personnel and damage to the generator set.

Fuels used in the generator set are flammable. Do not smoke or use open flames when performing maintenance. Failure to comply can result in flames and possible explosion and can cause injury or death to personnel and damage to the generator set.

NOTE

Fuel tank holds 66 gallons (250L). The following procedure is for using an external fuel source.

1. On EMCP, set ENGINE CONTROL switch to OFF/RESET.
2. At DIESEL FUEL fill port (16) remove protective cap and attach auxiliary fuel hose (17) to fuel connection marked EXTERNAL FUEL SUPPLY and to external fuel source.

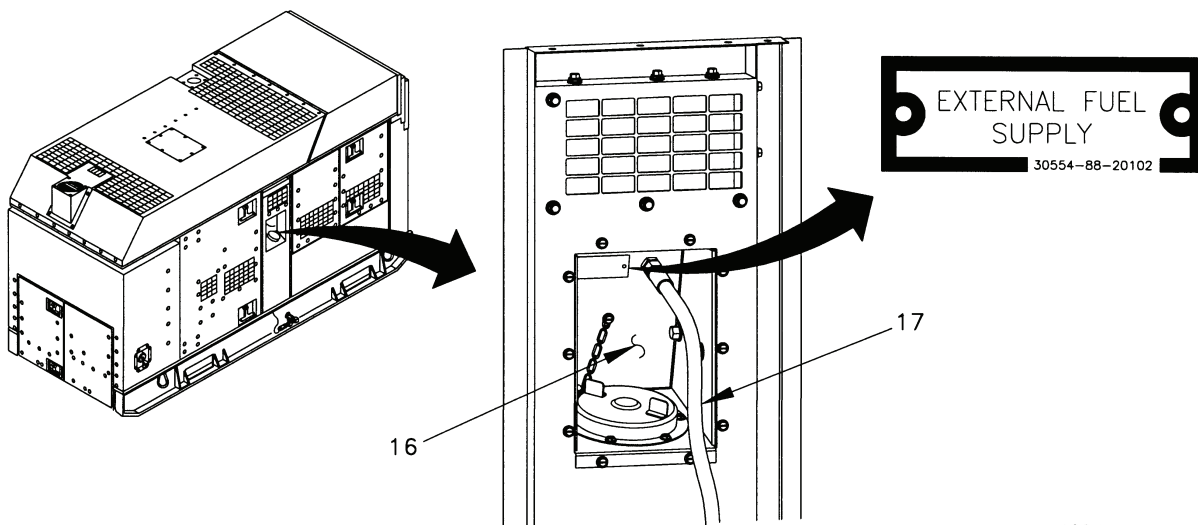

100KW-10-218C

END OF TASK

INITIAL ADJUSTMENTS BEFORE USE AND SELF-TEST**Initial Adjustments**

1. Open right rear side access door and ensure voltage Reconnection Board (WP 0005, Table 9) is set to match voltage requirements of load (WP 0006, Table 1). If voltage Reconnection Board must be changed and GSC and DVR must be programmed to give required output, notify maintenance.
2. If using external fuel supply, connect auxiliary fuel supply hose per WP 0006 00-8.
3. Open left rear generator housing door and set DEAD CRANK SWITCH to NORMAL (WP 0005 00-13).
4. On Electronic Modular Control Panel (EMCP) set AC CIRCUIT INTERRUPTER to OPEN (down) and release (WP 0005 00-1).

NOTE

FREQUENCY and VOLTAGE potentiometers should be adjusted in the center position. The position is not marked on the control panel. To center each potentiometer, the operator must turn the potentiometer as far as it will go in one direction and then rotate it five full turns in the opposite direction.

5. Adjust FREQUENCY potentiometer to center position. Rotate potentiometer clockwise until it stops. Then rotate it five full turns counterclockwise.
6. Adjust VOLTAGE potentiometer to center position. Rotate potentiometer clockwise until it stops. Then rotate it five full turns counterclockwise.
7. Set PARALLEL/UNIT switch to UNIT.
8. Pull out PUSH TO STOP EMERGENCY STOP switch.
9. Set Battery Disconnect Switch to ON (WP 0005 00-15).

Self-Test

1. On EMCP, set ENGINE CONTROL switch to COOL DOWN/STOP (WP 0005 00-1).
2. Verify that there is fuel in the TQG fuel tank. Full fuel tank will provide at a minimum eight hours of operation. Service as required per WP 0016 00.
3. On Generator Set Control (GSC), touch LAMP TEST on keypad. Ensure that all indicator lights on GSC light (WP 0005 00-4).
4. On Alarm Module, press LAMP TEST on panel. Ensure that alarm indicators light (WP 0005 00-10). Indicator lights turn on and alarm module horn sounds.
5. Press AC CIRCUIT INTERRUPTER press-to-test green indicator on the EMCP. Ensure indicator lights up. When press-to-test indicator is released light should go out (WP 0005 00-1).
6. If equipped with winterization kit, press HEATER press-to-test lamp on FUEL-FIRED HEATER CONTROL panel (WP 0005 00-18). Indicator should light.

END OF TASK

**100 kW TACTICAL QUIET GENERATOR SET
OPERATION UNDER USUAL CONDITIONS – Continued**

NATO SLAVE RECEPTACLE START OPERATION**WARNING**

Slave receptacle (NATO connector) is electrically live at all times and is unfused. The Battery Disconnect Switch does not remove power from the slave receptacle. NATO slave receptacle has 24 VDC even when Battery Disconnect Switch is set to OFF. This circuit is only dead when the batteries are fully disconnected. Disconnect the batteries before performing maintenance on the slave receptacle. Failure to comply can cause injury or death to personnel.

NOTE

The NATO slave receptacle can be used to start the generator set when batteries are discharged.

1. Connect one end of NATO slave cable to fully charged 24Vdc system and other end to discharged generator set NATO SLAVE RECEPTACLE.
2. On EMCP of discharged TQG, set ENGINE CONTROL switch to MANUAL START to start generator.
3. Remove NATO slave cable after generator set starts.

END OF TASK**OPERATING PROCEDURES****WARNING**

Metal jewelry can conduct electricity and become entangled in generator set components. Remove all metal jewelry when working on generator set. Failure to comply can cause injury or death to personnel.

High voltage is produced when the generator set is in operation. Never attempt to start the generator set unless it is properly grounded. Failure to comply can cause injury or death to personnel.

DC voltages are present at generator set electrical components even with generator set shut down. Avoid shorting any positive with ground/negative. Failure to comply can cause injury to personnel and damage to equipment.

WARNING

Exhaust discharge contains deadly gases including carbon monoxide. Do not operate generator set in an enclosed area unless exhaust discharge is properly vented outside. Failure to comply can cause injury or death to personnel.

OPERATING PROCEDURES – Continued**NOTE**

If generator set is to be operated in parallel with another unit, refer to **PARALLEL UNIT OPERATION (WP 0006 00-15)**.

Starting**WARNING**

High voltage is produced when the generator set is in operation. Never attempt to start the generator set unless it is properly grounded. Failure to comply can cause injury or death to personnel.

WARNING

Operating the generator set exposes personnel to a high noise level. Hearing protection must be worn when operating or working near the generator set when the generator set is running. Failure to comply can cause hearing damage to personnel.

CAUTION

The ideal load for the generator set is 80% of rated capacity. When operated at less than 80% of rated load, the diesel engine operates at lower temperatures and burns fuel incompletely resulting in carbon and moisture in the exhaust and carbon buildup or wetstacking in the engine. To avoid damage to the engine, if possible, mission loads should be distributed among available generator sets to achieve an average 80% load on each generator set.

The minimum load that the generator set should be operated at is 25% to 30% of its rated capacity. Operating at lower loads for long periods of time may damage the engine and cause wetstacking and damage to the engine. Engines operated at low loads for long periods of time should be operated at full load for a few hours until the wetstacking residues are burned out. This should be performed every 300 hours of generator set operation.

NOTE

At temperatures below 30°F (–1°C), the cold weather starting aid will be activated.

In normal operating temperatures, the EMCP will temporarily display low temperature alarm code AL2 upon startup. This is a normal part of the operation and the fault code will go away when starting is complete.

**100 kW TACTICAL QUIET GENERATOR SET
OPERATION UNDER USUAL CONDITIONS – Continued
OPERATING PROCEDURES – Continued**

0006 00

Starting – Continued

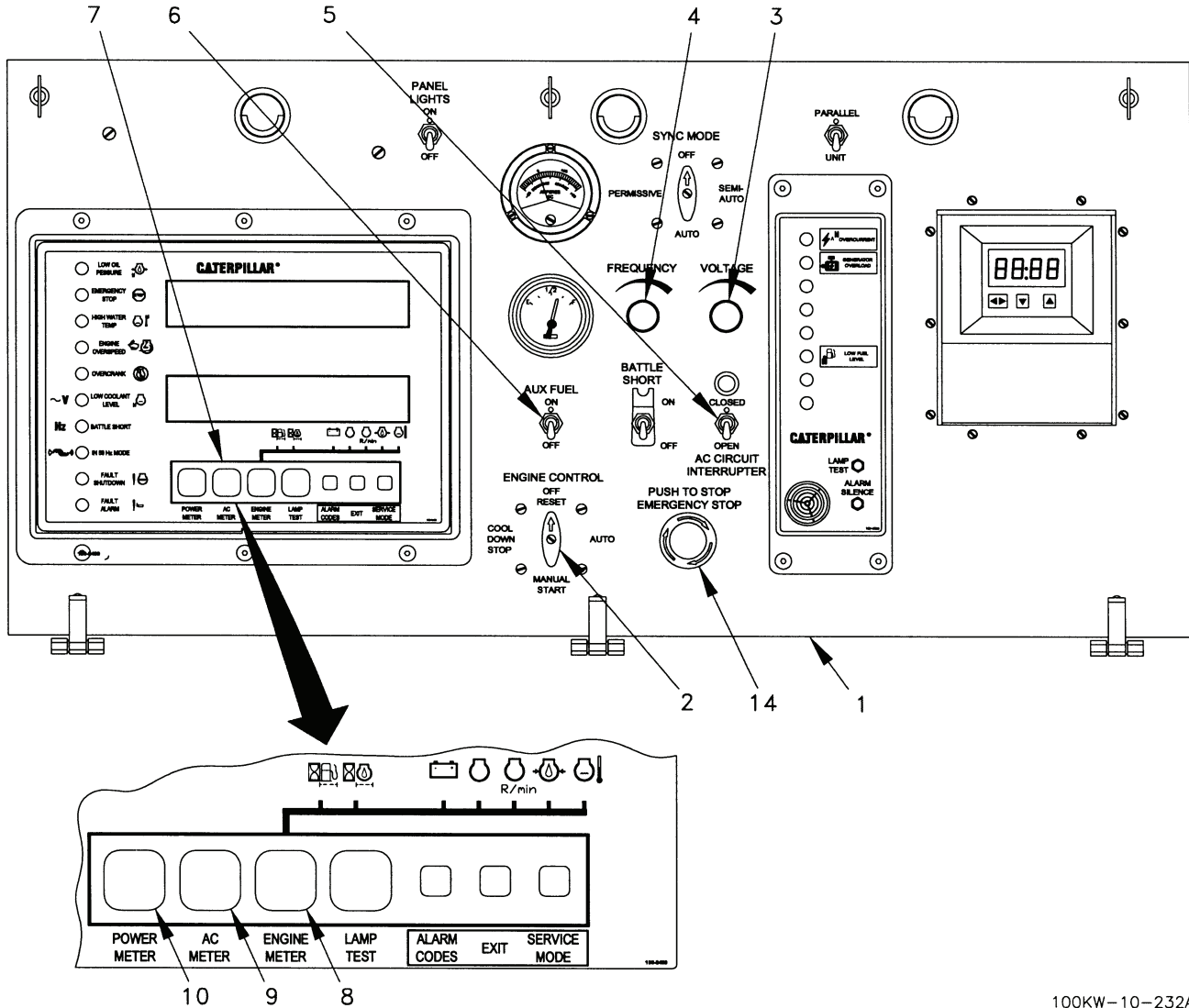

100KW-10-232A

1. Perform INITIAL ADJUSTMENTS BEFORE USE AND SELF-TEST procedures (WP 0006 00-9).

CAUTION

Do not crank engine in excess of fifteen seconds. Allow starter to cool at least fifteen seconds between attempted starts. Failure to observe this caution could result in damage to the starter.

2. Ensure that all generator set access doors, except control panel access door, are closed.
3. On EMCP (1), set ENGINE CONTROL switch (2) to MANUAL START. Engine should crank and ramp up to operating speed.

OPERATING PROCEDURES – Continued

Starting – Continued

4. Operate engine at no load for approximately 5 minutes or until coolant temperature reaches 100°F (38°C). If required, load can be applied immediately.
5. When TQG is running smoothly, fine tune VOLTAGE (3) and FREQUENCY (4) adjust potentiometers to required values for voltage and frequency if necessary.

WARNING

High voltage power is available when the main contactor is closed. Avoid accidental contact with live components. Ensure load cables are properly connected and the load cable door is shut before closing main contactor. Ensure load is turned off before closing main contactor. Ensure that soldiers working with/on loads connected to the generator set are aware that main contactor is about to be closed before closing main contactor. Failure to observe this warning can result in severe personal injury or death by electrocution.

6. Set AC CIRCUIT INTERRUPTER (5) switch to CLOSED (up) and release to connect load to TQG.
7. If operating with auxiliary fuel source, set AUX PUMP (6) switch to ON.
8. On GSC keypad (7), press ENGINE METER (8) and check coolant temperature to be 170°F to 200°F (77°C to 93°C) and oil pressure to be 35 to 70 psi (241 to 483 kPa).
9. On GSC keypad, press AC METER (9) to ensure voltage and frequency are still at rated values. Adjust if necessary.
10. Press POWER METER (10) on keypad and cycle through each phase position while observing current readings. If more than rated load is indicated in any phase, reduce load.
11. On PARALLELING RECEPTACLES panel (11), press TEST (12) pushbutton on GROUND FAULT CIRCUIT INTERRUPTER. Ensure that indicator window is red. Press RESET (13) pushbutton and ensure indicator is clear.

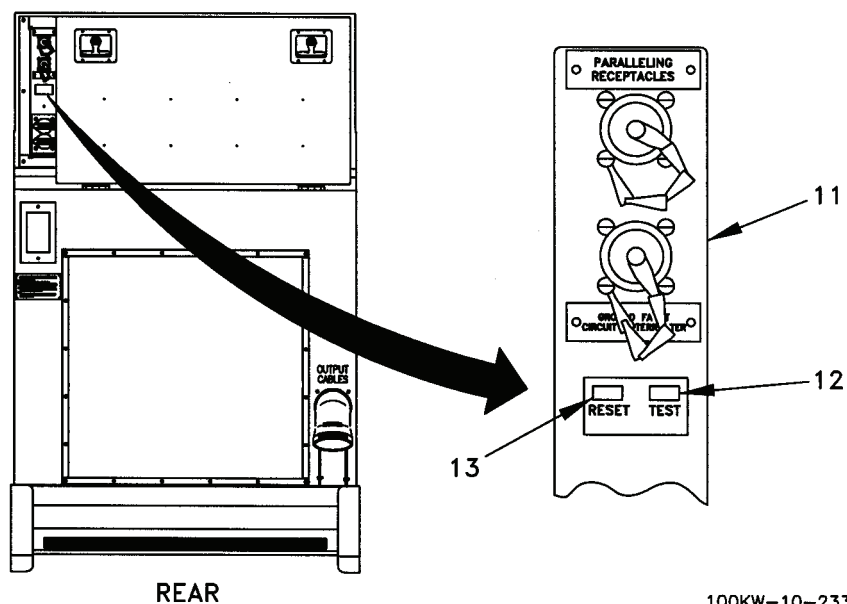

**100 kW TACTICAL QUIET GENERATOR SET
OPERATION UNDER USUAL CONDITIONS – Continued**

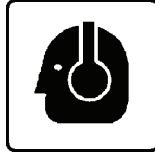
OPERATING PROCEDURES – Continued**Starting – Continued****WARNING**

Operating the generator set exposes personnel to a high noise level. Hearing protection must be worn when operating or working near the generator set when the generator set is running. Failure to comply can cause hearing damage to personnel.

NOTE

Perform all DURING PMCS checks every four hours if TQG is operating continuously.

12. Perform all DURING PMCS requirements per WP 0012 00.

Stopping Procedure

1. To remove load, on EMCP set AC CIRCUIT INTERRUPTER (5) switch to OPEN (down).

NOTE

ENGINE CONTROL switch may be set to MANUAL START to continue operation by turning counterclockwise.

2. Set ENGINE CONTROL (2) switch to COOL DOWN/STOP. This will allow generator set to operate with no load applied for 5 minutes. The generator set will shut down automatically.
3. Set ENGINE CONTROL switch to OFF/RESET.
4. Perform all AFTER PMCS requirements per WP 0012 00.
5. Open rear left housing door and set DEAD CRANK SWITCH to OFF (WP 0005 00-13).
6. Open battery compartment and set Battery Disconnect Switch to OFF (WP 0005 00-15).

END OF TASK**EMERGENCY STOPPING**

1. Press PUSH TO STOP EMERGENCY STOP (14) pushbutton to stop generator set.
2. Set ENGINE CONTROL switch to OFF/RESET.

END OF TASK

PARALLEL UNIT OPERATION (LOAD SHARING)

The following method of parallel operation will be used to share the load between two or more generator sets. Additional generator sets can be added as necessary by following the same procedures. The generator to be brought on line, also called the incoming generator is designated TQG No. 2. MEP-807A (PU-807A) (100 kW TQG) and MEP-809A (PU-809A) (200 kW TQG) generator sets have the same controls and operating systems. These generator sets may be safely paralleled.

The paralleling procedures describe three different modes of operation: AUTO mode, SEMI AUTO mode, and PERMISSIVE mode. AUTO mode is the preferred mode of operation and requires the least operator action. SEMI AUTO mode allows the operator to check anything or make manual adjustments prior to connecting generator sets in parallel. SEMI AUTO mode may be used if the operator has trouble paralleling the generator sets automatically. PERMISSIVE mode requires the operator to manually synchronize the generator sets prior to paralleling, using the displays on the GSC and control knobs on the EMCP. PERMISSIVE mode is useful for troubleshooting (WP 0005 00-2).

Pre-Operation

Metal jewelry can conduct electricity and become entangled in generator set components. Remove all metal jewelry when working on generator set. Failure to comply can cause injury or death to personnel.

High voltage is produced when this generator set is in operation. Make sure unit is completely shut down and free of any power source before attempting any repair or maintenance on the unit. Failure to comply can cause injury or death to personnel.

High voltage is produced when the generator set is in operation. Never attempt to start the generator set unless it is properly grounded. Failure to comply can cause injury or death to personnel.

Before making any connections for parallel operation or moving a generator set that has been operating in parallel, ensure there is no input to the load board and the generator sets are shut down. Failure to comply can cause injury or death to personnel by electrocution.

DC voltages are present at generator set electrical components even with generator set shut down. Avoid shorting any positive with ground/negative. Failure to comply can cause injury to personnel and damage to equipment.

CAUTION

Ensure generator sets are the correct size and model before attempting parallel operation. MEP-807A (PU-807A) (100 kW TQG) and MEP-809A (PU-809A) (200 kW TQG) generator sets may be safely paralleled.

When two or more generator sets are combined their total capacities must be greater than the demand of the electric load. If generator set capacities are not rated to support the load drawing power from them, damage to equipment may result.

**100 kW TACTICAL QUIET GENERATOR SET
OPERATION UNDER USUAL CONDITIONS – Continued**
PARALLEL UNIT OPERATION (LOAD SHARING) – Continued

Pre-Operation – Continued

CAUTION

The ideal load for the generator set is 80% of rated capacity. When operated at less than 80% of rated load, the diesel engine operates at lower temperatures and burns fuel incompletely resulting in carbon and moisture in the exhaust and carbon buildup or wetstacking in the engine. To avoid damage to the engine, if possible, mission loads should be distributed among available generator sets to achieve an average 80% load on each generator set.

The minimum load that the generator set should be operated at is 25% to 30% of its rated capacity. Operating at lower loads for long periods of time may damage the engine and cause wetstacking and damage to the engine. Engines operated at low loads for long periods of time should be operated at full load for a few hours until the wetstacking residues are burned out. This should be performed every 300 hours of generator set operation.

1. Ensure load requirement is equal or below combined rated capacity of generator sets. If load is greater than combined capacity of the generator sets that are being paralleled, the generators will overload and the TQG could be damaged.
2. Determine voltage requirements of load. Ensure voltage Reconnection Boards (WP 0005, Table 9) of generator sets match voltage requirements of load (WP 0006, Table 1).
3. Notify maintenance to change Reconnection Board and to reprogram the GSC and DVR to obtain required output.
4. Inside EMCP control box assembly, set ISOCHRONOUS/DROOP switch to DROOP for all generators to be paralleled (WP 0005 00-12).
5. Identify one generator set as TQG No. 1 and the other as incoming TQG No. 2. If a 200 kW TQG is being paralleled with a 100 kW TQG, designate the 200 kW TQG as No. 1.
6. On each generator set, set ENGINE CONTROL to OFF/RESET, Battery Disconnect Switch to OFF, and DEAD CRANK SWITCH to OFF.
7. Verify that generator sets are grounded. Ground each generator set (see WP 0006 00-2).

NOTE

Common ground should be used.

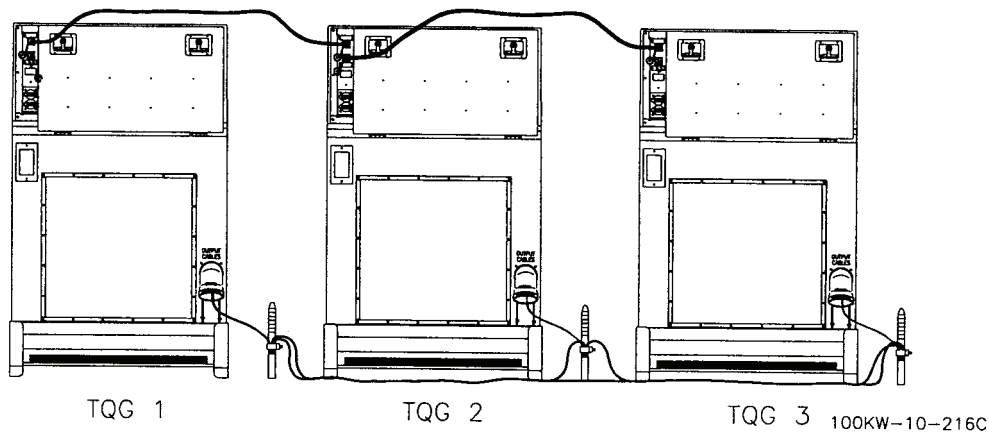

PARALLEL UNIT OPERATION (LOAD SHARING) – Continued

Pre-Operation – Continued

8. Remove paralleling cable from storage box located inside battery compartment access door.
9. Connect paralleling cable between connectors on PARALLELING RECEPTACLES panel (WP 0005 00, Table 7).
10. Connect generator sets to load observing proper phase polarity.

CAUTION

Do not close the AC CIRCUIT INTERRUPTER switch on either of the generator sets, nor close the load contactor at load until specifically directed to do so. Closing any of these devices at any other time may severely damage one or more generator sets.

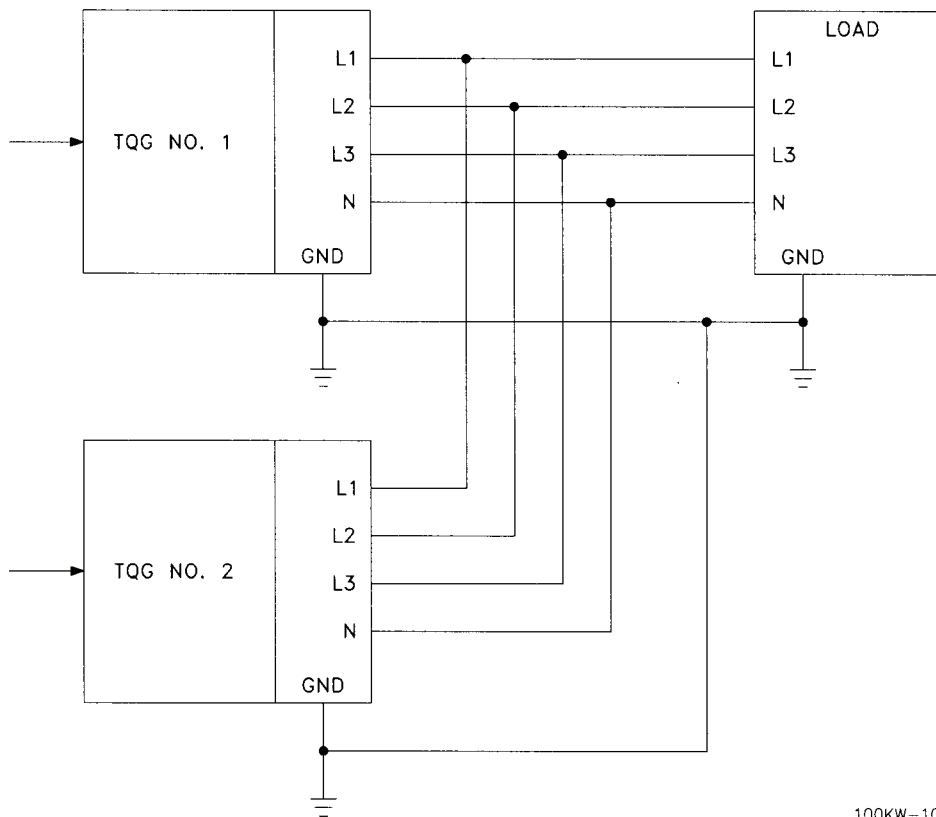

100KW-10-217A

**100 kW TACTICAL QUIET GENERATOR SET
OPERATION UNDER USUAL CONDITIONS – Continued**

PARALLEL UNIT OPERATION (LOAD SHARING) – Continued

Operation in AUTO Mode



CAUTION

When paralleling a 200 kW TQG to a 100 kW TQG that is supplying a load, an unstable condition can occur. This condition does not occur when paralleling at no load or when paralleling a 100 kW TQG to a 200 kW TQG that is supplying a load.

When you connect a 200 kW TQG to the load bus with a 100 kW TQG already under load and the load sharing becomes unstable, you should immediately disconnect the 100 kW TQG from the load bus to prevent damage to equipment by setting the 100 kW TQG AC CIRCUIT INTERRUPTER switch to OPEN. The 100 kW TQG should then be synchronized to the load bus and the AC CIRCUIT INTERRUPTER switch set to CLOSED.



1. Perform INITIAL ADJUSTMENTS BEFORE USE AND SELF-TEST procedures (WP 0006 00-9).
2. On each generator EMCP, set ENGINE CONTROL switch to MANUAL START and start each set.
3. Rotate VOLTAGE adjust potentiometers to obtain same voltage indication on each set.
4. Rotate FREQUENCY adjust potentiometers to obtain same frequency indication on each set.
5. Ensure that all external load contactors between the generator sets and the load are open.
6. On TQG No. 1 EMCP, set SYNC MODE switch to AUTO. The AC CIRCUIT INTERRUPTER will close and indicator will light.
7. On TQG No. 1 GSC panel keypad, press and hold POWER METER to display %kW continuously on the lower display.
8. Set UNIT/PARALLEL switch on both units to PARALLEL.

CAUTION

If square symbol  on synchroscope (lower display) does not stop at center and synchronizing lights (~V, HZ, and ) on left side of GSC panels on paralleling generator sets do not glow steady yellow, the voltage, frequency and phasing are wrong and must be corrected. Failure to observe this caution can result in damage to generator sets.

NOTE

When generator sets are operated in parallel, a switch or external load contactor should be placed between the generator set and load to connect and disconnect power.

9. If square symbol  on synchroscope (lower display) does not stop at center and synchronizing lights (~V, HZ, and ) on left side of GSC panels on paralleling generator sets do not glow steady yellow, shut down the generator sets.
10. Check that load cables are connected properly.
11. Repeat steps 1 thru 8 above.
12. On TQG No. 2 EMCP, set SYNC MODE switch to AUTO. Set will automatically synchronize and close AC CIRCUIT INTERRUPTER.

PARALLEL UNIT OPERATION (LOAD SHARING) – Continued**Operation in AUTO Mode – Continued****NOTE**

With no load the %kW readings on all sets in parallel should be less than plus or minus 5%.

With no load the TOTAL Amperes on all sets in parallel should be less than plus or minus 5% of generator set rated current.

Ideally there should be zero %kW and zero TOTAL Amperes. Once load is applied to paralleled sets, slight adjustments may be needed to keep the values balanced to within plus or minus 5% of one another.

13. On TQG No. 2 GSC panel keypad, press POWER METER to display %kW continuously on the lower display. Make slight adjustment of the FREQUENCY adjust potentiometers to balance the kW between all sets at the lowest possible reading.
14. Read TOTAL Amperes on the upper display (right side) and make slight adjustments of the VOLTAGE adjust potentiometers to balance this reading between all sets at the lowest possible reading. This must be performed as quickly as possible and repeated back and forth between VOLTAGE and FREQUENCY adjust potentiometers to prevent reverse power and overcurrent faults.
15. Perform steps 8 thru 14 for each additional set to be paralleled.
16. Generator sets are now operating in parallel with no load.
17. Close all external load contactors between the generator sets and load. Generator sets are now operating with load applied.
18. Observe upper display for voltage and TOTAL Amperes readings and the lower display for kW and kVAR readings on all TQG units. Make very small adjustments to the VOLTAGE and FREQUENCY potentiometers to maintain balanced readings of TOTAL Amperes, % kW, and kVAR across all units in parallel.
19. Pressing POWER METER on GSC keypad, periodically compare kW and kVAR readings on lower display of all generator sets. If readings are not within plus or minus 10% of one another, notify maintenance.

Operation in SEMI AUTO Mode**CAUTION**

When paralleling a 200 kW TQG to a 100 kW TQG that is supplying a load, an unstable condition can occur. This condition does not occur when paralleling at no load or when paralleling a 100 kW TQG to a 200 kW TQG that is supplying a load.

When you connect a 200 kW TQG to the load bus with a 100 kW TQG already under load and the load sharing becomes unstable, you should immediately disconnect the 100 kW TQG from the load bus to prevent damage to equipment by setting the 100 kW TQG AC CIRCUIT INTERRUPTER switch to OPEN. The 100 kW TQG should then be synchronized to the load bus and the AC CIRCUIT INTERRUPTER switch set to CLOSED.



1. Perform INITIAL ADJUSTMENTS BEFORE USE AND SELF-TEST procedures (WP 0006 00-9).
2. On each generator EMCP, set ENGINE CONTROL switch to MANUAL START.
3. Rotate VOLTAGE adjust potentiometers to obtain same voltage indication on each set.
4. Rotate FREQUENCY adjust potentiometers to obtain same frequency indication on each set.
5. Ensure that all external load contactors between the generator sets and the load are open.

**100 kW TACTICAL QUIET GENERATOR SET
OPERATION UNDER USUAL CONDITIONS – Continued**

PARALLEL UNIT OPERATION (LOAD SHARING) – Continued
Operation in SEMI AUTO Mode – Continued



6. On TQG No. 1 EMCP, position AC CIRCUIT INTERRUPTER switch to CLOSED until press-to-test green indicator lights.
7. On TQG No. 1 EMCP, set SYNC MODE switch to OFF, and on GSC panel keypad, press and hold POWER METER to display %kW continuously.
8. Set UNIT/PARALLEL switch on both units to PARALLEL.
9. On TQG No. 2 EMCP, set SYNC MODE switch to SEMI AUTO.
10. Perform steps 8 and 9 for each additional set to be paralleled.

CAUTION



If square symbol  on synchroscope (lower display) does not stop at center and synchronizing lights (~V, HZ, and ) on left side of GSC panels on paralleling generator sets do not glow steady yellow, the voltage, frequency and phasing are wrong and must be corrected. Failure to observe this caution can result in damage to generator sets.

NOTE

When generator sets are operated in parallel, a switch or external load contactor should be placed between the generator set and load to connect and disconnect power.

11. If square symbol  on synchroscope (lower display) does not stop at center and synchronizing lights (~V, HZ, and ) on left side of GSC panels on paralleling generator sets do not glow steady yellow, shut down the generator sets.
12. Check that load cables are connected properly.
13. Repeat steps 1 thru 10 above.
14. On incoming TQG No. 2 EMCP, adjust VOLTAGE potentiometer until yellow ~V indicator on GSC stops flashing. (AC CIRCUIT INTERRUPTER switch cannot be set to CLOSE unless voltage is stable.)
15. On incoming TQG No. 2, adjust FREQUENCY potentiometers as necessary to match generator set frequencies. On GSC lower display, observe that the square symbol on synchroscope of TQG No. 2 stops rotating. Clockwise rotation indicates that frequency of TQG No. 2 power is higher than load bus. Counterclockwise rotation indicates that frequency of TQG No. 2 power is less than load bus.

NOTE

When the square synchroscope symbol  is centered at top of display and stable and ~V, HZ, and  yellow indicator lights all glow steady, the paralleling generator sets are in phase.

16. When synchroscope (lower display) indicates that TQG frequencies and phases match and synchronizing lights ~V, HZ, and  on GSC panels stop flashing, set AC CIRCUIT INTERRUPTER switch on incoming TQG No. 2 to CLOSED until press-to-test green indicator lights. Generator sets are now operating in parallel with no load.
17. Immediately set SYNC MODE switch to OFF, and press POWER METER key on GSC keypad to indicate %kW.
18. Read TOTAL Amperes on the upper display (right side) and make slight adjustments of the VOLTAGE adjust potentiometers to balance this reading between all sets at the lowest possible reading. This must be performed as quickly as possible and repeated back and forth between VOLTAGE and FREQUENCY adjust potentiometers to prevent reverse power and overcurrent faults.
19. Repeat steps 14 thru 18 for each additional generator set to be paralleled.

PARALLEL UNIT OPERATION (LOAD SHARING) – Continued**Operation in SEMI AUTO Mode – Continued**

20. Close all external load contactors between the generator sets and load. Generator sets are now operating with load applied.
21. Observe upper display for voltage and total current readings and the lower display for kW and kVAR readings on all TQG units. Make very small adjustments to the VOLTAGE and FREQUENCY potentiometers to maintain balanced reading of total amperes, %kW, and kVAR across all units in parallel.
22. Pressing POWER METER on GSC keypad, periodically compare kW and kVAR readings on lower display of all generator sets. If readings are not within plus or minus 10% of one another, notify maintenance.



Operation in PERMISSIVE Mode**CAUTION**

When paralleling a 200 kW TQG to a 100 kW TQG that is supplying a load, an unstable condition can occur. This condition does not occur when paralleling at no load or when paralleling a 100 kW TQG to a 200 kW TQG that is supplying a load.

When you connect a 200 kW TQG to the load bus with a 100 kW TQG already under load and the load sharing becomes unstable, you should immediately disconnect the 100 kW TQG from the load bus to prevent damage to equipment by setting the 100 kW TQG AC CIRCUIT INTERRUPTER switch to OPEN. The 100 kW TQG should then be synchronized to the load bus and the AC CIRCUIT INTERRUPTER switch set to CLOSED.



1. Perform INITIAL ADJUSTMENTS BEFORE USE AND SELF-TEST procedures (WP 0006 00-9).
2. On each generator set EMCP, set ENGINE CONTROL switch to MANUAL START.
3. Rotate VOLTAGE adjust potentiometers to obtain same voltage indication on each set.
4. Rotate FREQUENCY adjust potentiometers to obtain same frequency indication on each set.
5. Ensure that all external load contactors between the generator sets and the load are open.
6. On TQG No. 1 EMCP position and hold AC CIRCUIT INTERRUPTER switch to CLOSED until press-to-test green indicator lights.
7. On TQG No. 1 EMCP, set SYNC MODE switch to OFF, and on GSC panel keypad, press and hold POWER METER to display %kW continuously.
8. Set UNIT/PARALLEL switch on both units to PARALLEL.
9. On TQG No. 2 EMCP, set SYNC MODE switch to PERMISSIVE.
10. Perform steps 8 and 9 for each additional set to be paralleled.

PARALLEL UNIT OPERATION (LOAD SHARING) – Continued
Operation in PERMISSIVE Mode – Continued
CAUTION



If square symbol  on synchroscope (lower display) does not stop at center and synchronizing lights (~V, HZ, and ) on left side of GSC panels on paralleling generator sets do not glow steady yellow, the voltage, frequency and phasing are wrong and must be corrected. Failure to observe this caution can result in damage to generator sets.

NOTE

When generator sets are operated in parallel, a switch or external load contactor should be placed between the generator set and load to connect and disconnect power.

11. If square symbol  on synchroscope (lower display) does not stop at center and synchronizing lights (~V, HZ, and ) on left side of GSC panels on paralleling generator sets do not glow steady yellow, shut down the generator sets.
12. Check that load cables are connected properly.
13. Repeat steps 1 thru 10 above.
14. On incoming TQG No. 2 EMCP, adjust VOLTAGE potentiometer until yellow ~V indicator on GSC stops flashing. (AC CIRCUIT INTERRUPTER switch cannot be set to CLOSE unless voltage is stable.)
15. On incoming TQG No. 2, adjust FREQUENCY potentiometer as necessary to match generator set frequencies. On GSC lower display, observe that the square symbol on synchroscope of TQG No. 2 stops rotating. Clockwise rotation indicates that frequency of TQG No. 2 power is higher than load bus. Counterclockwise rotation indicates that frequency of TQG No. 2 power is less than load bus.

NOTE

When the square synchroscope symbol  is centered at top of display and stable and ~V, HZ, and  yellow indicator lights all glow steady, the paralleling generator sets are in phase.

16. When synchroscope (lower display) indicates that TQG frequencies and phases match and synchronizing lights ~V, HZ, and  on GSC panels stop flashing, set AC CIRCUIT INTERRUPTER switch on incoming TQG No. 2 to CLOSED until press-to-test green indicator lights. Generator sets are now operating in parallel with no load.
17. Immediately set SYNC MODE switch to OFF, and press POWER METER key on GSC keypad to indicate %kW.
18. Read TOTAL Amperes on the upper display (right side) and make slight adjustments of the VOLTAGE adjust potentiometers to balance this reading between all sets at the lowest possible reading. This must be performed as quickly as possible and repeated back and forth between VOLTAGE and FREQUENCY adjust potentiometers to prevent reverse power and overcurrent faults.
19. Repeat steps 14 thru 18 for each additional generator set to be paralleled.
20. Close all external load contactors between the generator sets and load. Generator sets are now operating with load applied.
21. Observe upper display for voltage and total current readings and the lower display for kW and kVAR readings on all TQG units. Make very small adjustments to the VOLTAGE and FREQUENCY potentiometers to maintain balanced reading of total amperes, %kW, and kVAR across all units in parallel.
22. Pressing POWER METER on GSC keypad, periodically compare kW and kVAR readings on lower display of all generator sets. If readings are not within plus or minus 10% of one another, notify next higher level of maintenance.

PARALLEL UNIT OPERATION (LOAD SHARING) – Continued**Removal from Parallel Operation****WARNING**

If necessary to move a generator set that has been operating in parallel with another generator set, shut down all generator sets prior to removing load cables or ground. Failure to comply can cause injury or death to personnel by electrocution.

CAUTION

Before removing generator set from parallel operation, make sure that load does not exceed full load rating of generator set(s) remaining on the line. Failure to observe this caution can result in damage to generator set.

1. On EMCP, set AC CIRCUIT INTERRUPTER switch to OPEN (down) until press-to-test green indicator goes out.
2. Return UNIT/PARALLEL switch to UNIT.
3. Set ENGINE CONTROL switch to COOL DOWN/STOP. Wait 5 minutes with no load.
4. Set ENGINE CONTROL switch to OFF/RESET.
5. Perform all After PMCS requirements per WP 0012 00.
6. Open rear left housing door and set DEAD CRANK SWITCH to OFF.
7. Open battery compartment and set Battery Disconnect Switch to OFF.
8. Push in PUSH TO STOP EMERGENCY STOP pushbutton.

END OF TASK

100 kW TACTICAL QUIET GENERATOR SET
 OPERATION UNDER USUAL CONDITIONS – Continued
 DECALS AND INSTRUCTION PLATES

0006 00

U.S. DEPARTMENT OF DEFENSE NATO STANDARD OTAN			
GENERATOR SET, DIESEL ENGINE 100KW 50/60HZ			
MODEL	0116-1000	NSN	6115-01-296-1463
SER NO.		REG NO.	
TM	9-6115-729-10	NAVFAC	19-50-26
TO	35C2-3-519-1	TM	07464C-10
VOLTS	120/208V 3PH, 240/416V 3PH, 50/60 HZ		
AMPS	347/174 60HZ, 289/145 50HZ	PF	0.8
DRY WT	5500 LB	LG	106 IN
		W	40 IN
		HGT	65 IN
DATE MFD		CONTR NO.	DAAB07-00-D-B207
WARRANTY		DATE INSP	
MFD BY	FERMONT	INSP STAMP	

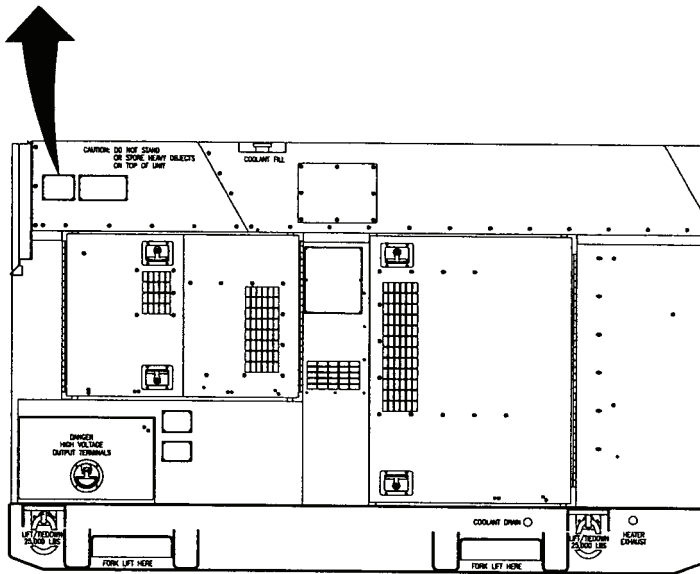

RIGHT SIDE

100KW-10-220E

DECALS AND INSTRUCTION PLATES – Continued

GENERATOR SET, DIESEL FUELED
MODE (50/60 HERTZ), SIZE 100 (100 KW)

KW CAPACITY			PF	FREQ	FUEL	OUTPUT VOLTAGE 3PH, 4W	VOLTAGE ADJUST RANGE	CURRENT CAPACITY AMPS
120 DEG F S/L	95 DEG F 4000 FT	95 DEG F 8000 FT						
100	100	86	.80	60	I-D/2-D	120/208	197-240	347
100	100	86	.80	60	I-D/2-D	240/416	395-480	174
83.3	83.3	71.5	.80	50	I-D/2-D	120/208	190-213	289
83.3	83.3	71.5	.80	50	I-D/2-D	240/416	380-426	145
100	100	86	.80	60	JP5/JP8	120/208	197-240	347
100	100	86	.80	60	JP5/JP8	240/416	395-480	174
83.3	83.3	71.5	.80	50	JP5/JP8	120/208	190-213	289
83.3	83.3	71.5	.80	50	JP5/JP8	240/416	380-426	145

0116-1900-03

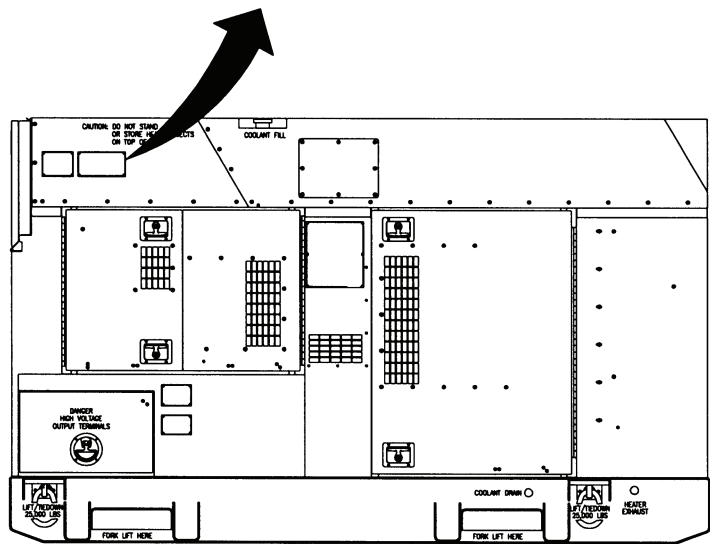

RIGHT SIDE

100KW-10-221A

100 kW TACTICAL QUIET GENERATOR SET
 OPERATION UNDER USUAL CONDITIONS – Continued
 DECALS AND INSTRUCTION PLATES – Continued

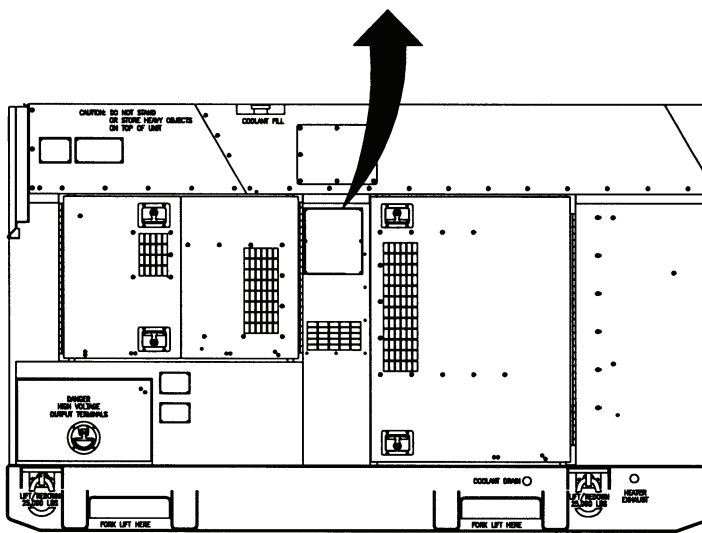
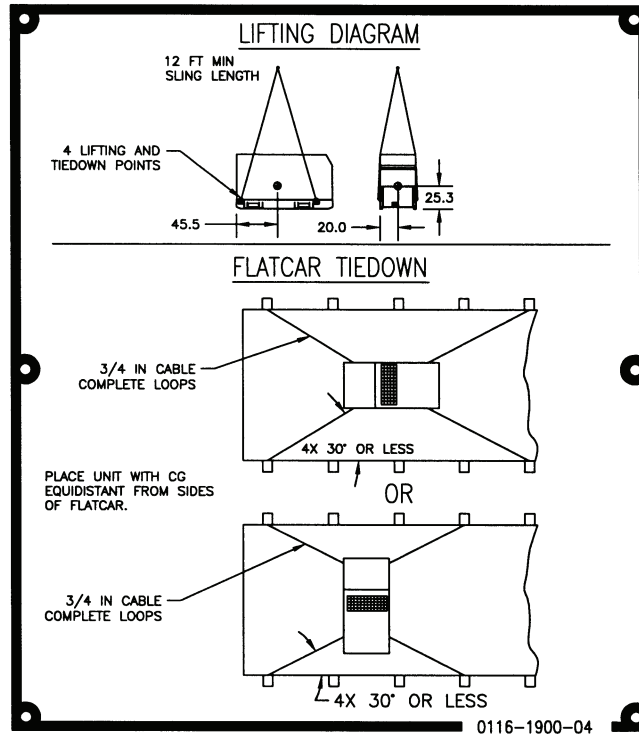

RIGHT SIDE

100KW-10-222

DECALS AND INSTRUCTION PLATES – Continued

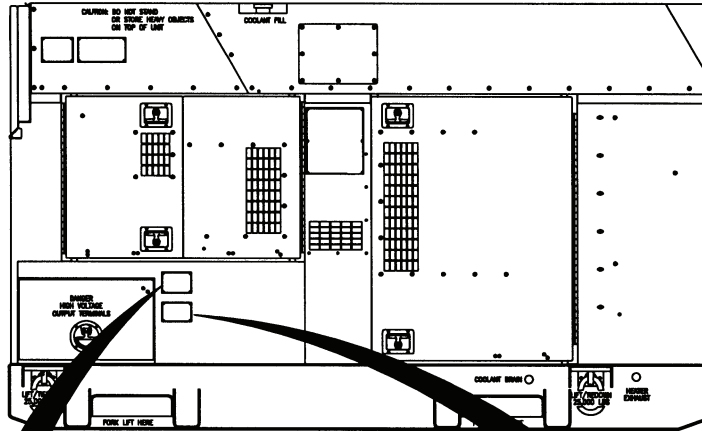

RIGHT SIDE

CAUTION
 TO AVOID DAMAGE
 TO THE LOAD
 FIRST CHECK VOLTAGE,
 FREQUENCY AND PHASE
 REQUIREMENTS OF THE
 USING EQUIPMENT.

30554-88-20110

WARNING

DO NOT OPERATE THE GENERATOR SET UNTIL IT HAS BEEN CONNECTED TO A SUITABLE GROUND. SEE OPERATOR'S MANUAL.

- 4 WIRE CONNECTION -

CONNECT THE LOAD LINES TO "L1", "L2" & "L3", TERMINALS. CONNECT THE NEUTRAL LINE TO "LO" TERMINAL.

- 5 WIRE CONNECTION -

CONNECT THE LOAD LINES TO "L1", "L2" & "L3" TERMINALS. CONNECT THE NEUTRAL LINE TO "LO" TERMINAL. CONNECT THE 5TH WIRE (GROUND) TO THE "GND" TERMINAL.

30554-88-20126

100KW-10-223

100 kW TACTICAL QUIET GENERATOR SET
OPERATION UNDER USUAL CONDITIONS – Continued
DECALS AND INSTRUCTION PLATES – Continued

0006 00

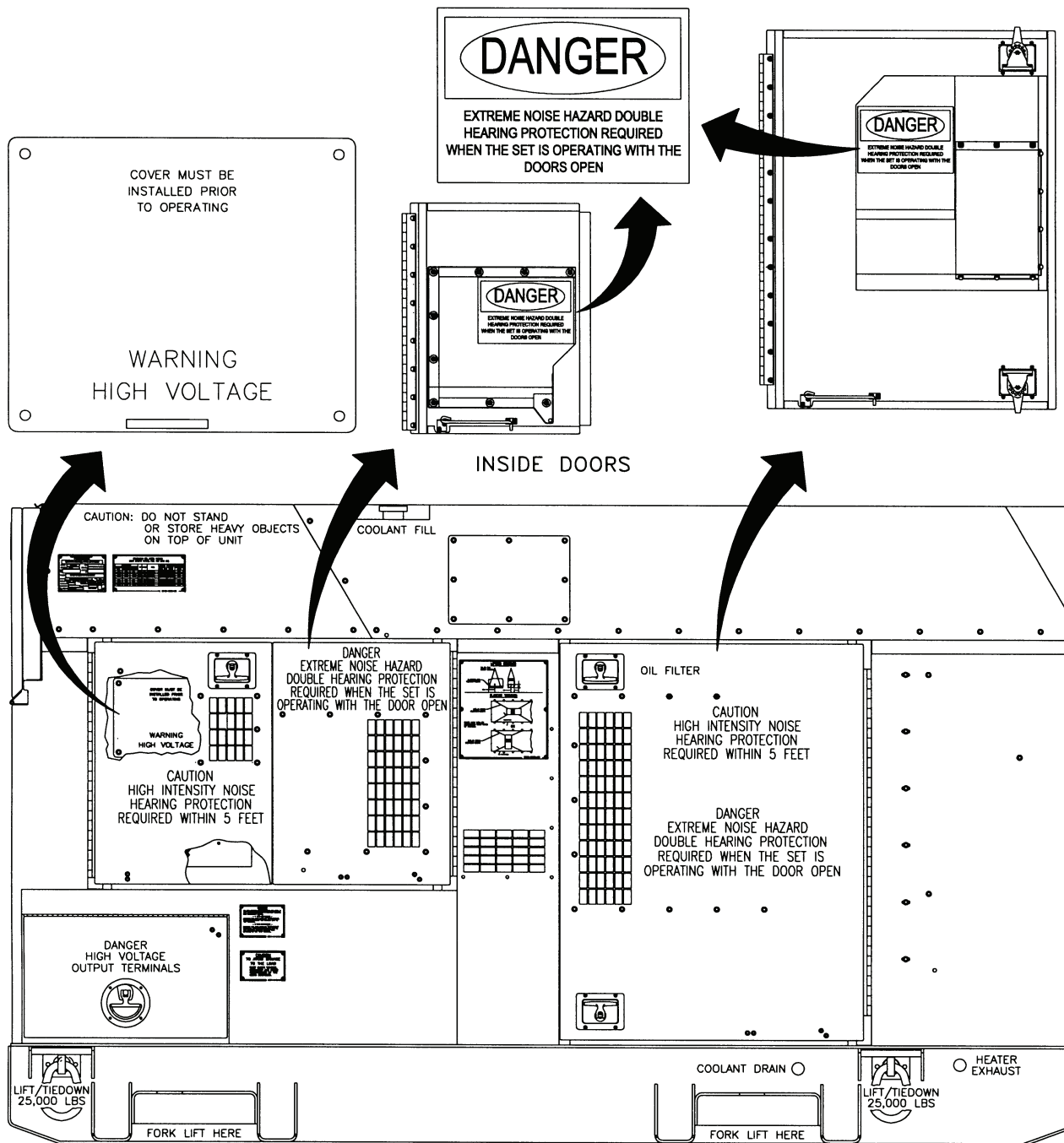

RIGHT SIDE WARNINGS, CAUTIONS, LABELS

100KW-10-238

DECALS AND INSTRUCTION PLATES – Continued

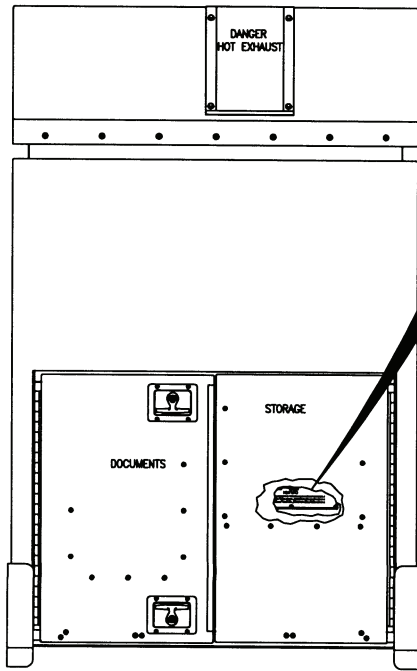
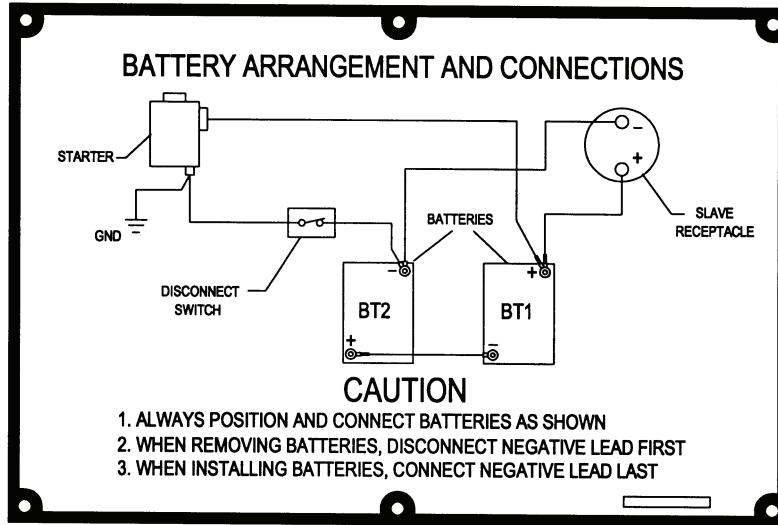

FRONT

100KW-10-224

100 kW TACTICAL QUIET GENERATOR SET
OPERATION UNDER USUAL CONDITIONS – Continued
DECALS AND INSTRUCTION PLATES – Continued

0006 00

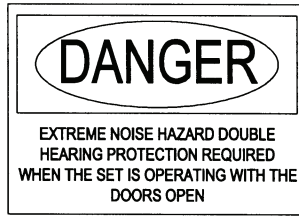
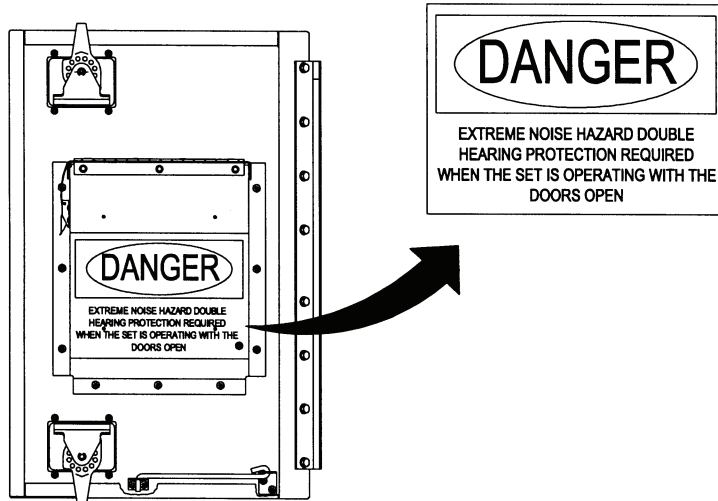

INSIDE DOOR

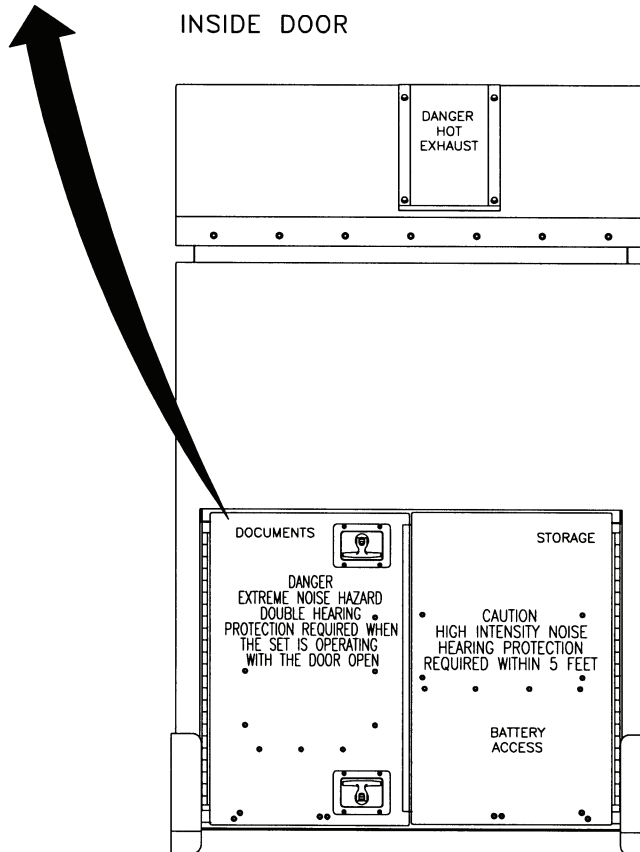

FRONT WARNINGS, CAUTIONS, LABELS

100KW-10-240

100 kW TACTICAL QUIET GENERATOR SET
OPERATION UNDER USUAL CONDITIONS – Continued

0006 00

DECALS AND INSTRUCTION PLATES – Continued

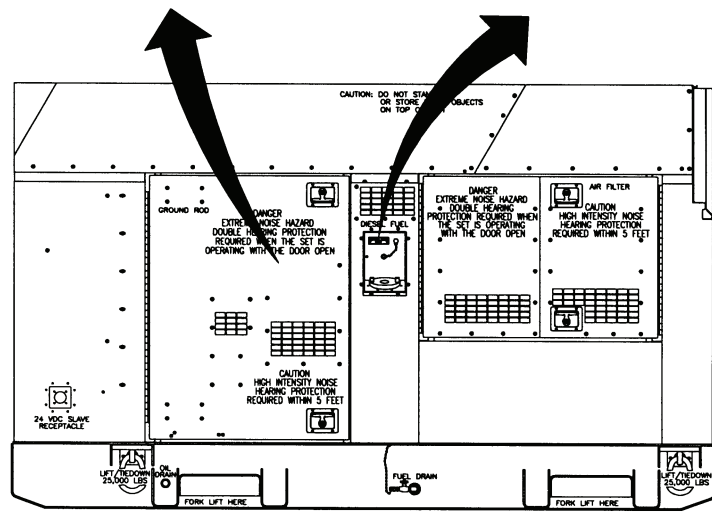
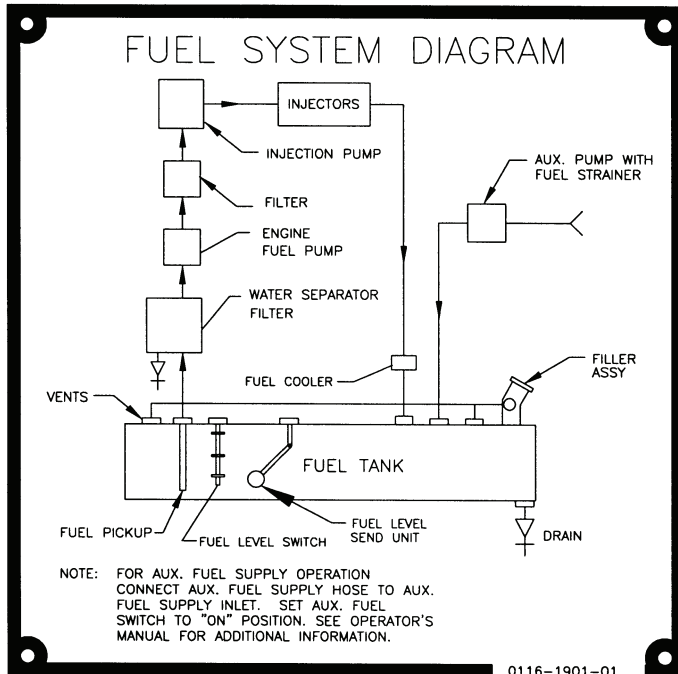

LEFT SIDE

100KW-10-225A

**100 kW TACTICAL QUIET GENERATOR SET
OPERATION UNDER USUAL CONDITIONS – Continued
DECALS AND INSTRUCTION PLATES – Continued**

0006 00

US DEPARTMENT OF DEFENSE	
NOM	GENERATOR, ALTERNATING CURRENT, SYNCHRONOUS BRUSHLESS
MAKE	MILITARY DESIGN
MODEL	0116-1000
SER NO.	NO OF WIRES 10
VOLTS	120/208, 240/416 AMPS 347/174, 289/145
KW	100 KVA 125 PF 0.8
HERTZ	50/60 PH 3 RPM 1500/1800
MFD BY	MARATHON ELECTRIC
0116-1900-02	

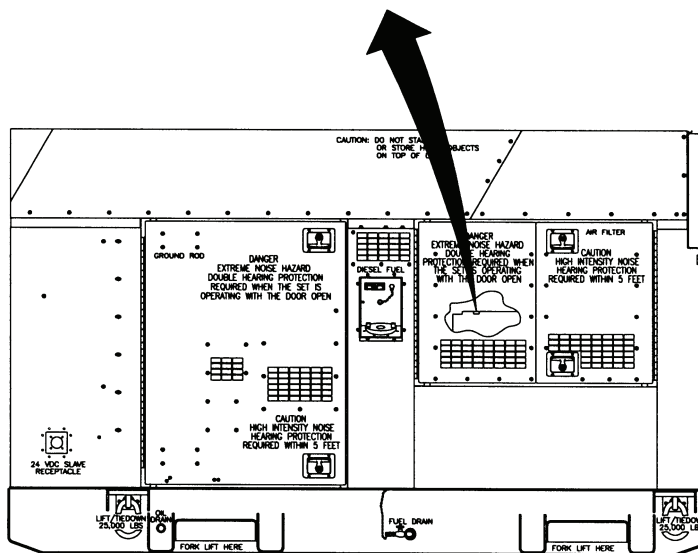

LEFT SIDE

100KW-10-228A

100 kW TACTICAL QUIET GENERATOR SET
OPERATION UNDER USUAL CONDITIONS – Continued

0006 00

DECALS AND INSTRUCTION PLATES – Continued

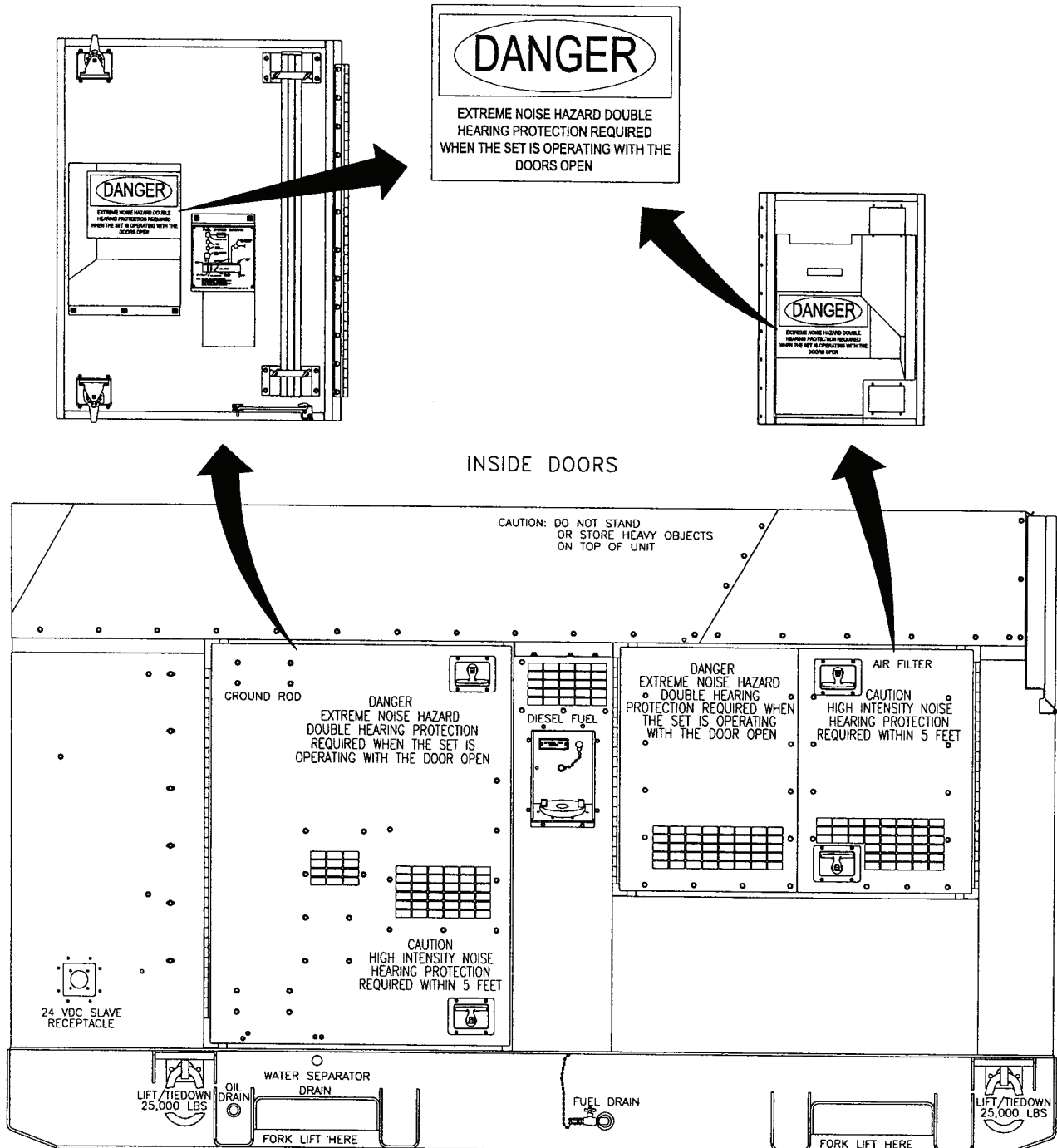

LEFT SIDE WARNINGS, CAUTIONS, LABELS

100KW-10-239A

**100 kW TACTICAL QUIET GENERATOR SET
OPERATION UNDER USUAL CONDITIONS – Continued
DECALS AND INSTRUCTION PLATES – Continued**

0006 00

CAUTION - TO AVOID SHOCK HAZARD SET FRAME MUST BE GROUNDED. CONNECT AWG NO. 6 OR LARGER FROM SET GROUND (GND) TERMINAL TO EARTH GROUND

BATTERY NEGATIVE TERMINAL IS CONNECTED TO CHASSIS GROUND WHEN BDS (BATTERY DISCONNECT SWITCH) IS CLOSED.

1. PRESTART CHECKS
 A. CHECK RADIATOR COOLANT, ENGINE LUBE OIL AND FUEL.
 B. DRAIN WATER FROM FUEL-WATER SEPARATOR FILTER IF PRESENT.
 C. PLACE CONTROL SWITCHES TO OFF OR EQUIVALENT POSITION. TURN BATTERY DISCONNECT SW TO ON.

2. NORMAL START
 A. PLACE THE MASTER SW IN THE MANUAL START POSITION. ENGINE WILL START AND COME UP TO THE PRESET VOLTAGE AND FREQUENCY. ADJUST FREQUENCY AND VOLTAGE AS REQUIRED. AT TEMPERATURES BELOW APPROXIMATELY 30°F THE PREHEATER WILL BE AUTOMATICALLY ENERGIZED FOR UP TO 30 SECONDS PRIOR TO CRANKING.
 B. UNDER NORMAL CONDITIONS OPERATE ENGINE AT NO LOAD FOR APPROXIMATELY 5 MINUTES OR UNTIL COOLANT

TEMPERATURE REACHES 100°F. IF REQUIRED LOAD CAN BE APPLIED IMMEDIATELY. CLOSE THE AC CIRCUIT INTERRUPTER BY MOMENTARILY PLACING THE AC CIRCUIT INTERRUPTER SW IN THE CLOSED POSITION.

3. STOPPING THE SET
 A. REMOVE THE LOAD BY MOMENTARILY PLACING THE AC CIRCUIT INTERRUPTER SW IN THE OPEN POSITION.
 B. ALLOW THE SET TO COOL DOWN FOR APPROXIMATELY 5 MINUTES BY PLACING THE CONTROL SW IN THE COOL DOWN STOP POSITION. THE SET WILL AUTOMATICALLY SHUT DOWN AFTER 5 MINUTES OF OPERATION. IF REQUIRED THE SET CAN BE SHUT DOWN IMMEDIATELY BY PLACING THE CONTROL SW IN THE SHUT DOWN POSITION.

4. PARALLEL OPERATION
 A. MAKE LOAD CABLE INTERCONNECTIONS BETWEEN SETS TO BE PARALLELED AND THE LOAD. CONNECT PARALLELING CABLE BETWEEN ALL SETS TO BE OPERATED IN PARALLEL.
 B. PLACE UNIT PARALLEL SW ON ALL UNITS TO BE PARALLELED IN THE PARALLEL POSITION.
 C. PLACE ISOCRONOUS DROOP SW ON ALL UNITS TO BE PARALLELED IN THE DROOP POSITION.

OPERATING INSTRUCTIONS
 D. PLACE SYNC MODE SELECTOR SW ON FIRST SET TO BE PARALLELED IN THE AUTO PARALLEL POSITION. THE AC LOAD CONTACTOR WILL AUTOMATICALLY CLOSE ONTO THE DEAD BUS.
 E. REPEAT STEP D ABOVE FOR EACH OF THE SETS TO BE PARALLELED. THESE SETS WILL BE AUTOMATICALLY SYNCHRONIZED TO THE BUS AND THE AC LOAD CONTACTOR AUTOMATICALLY CLOSED.
 F. IF REQUIRED THE LOAD SHARING BETWEEN UNITS CAN BE EQUALIZED BY ADJUSTING THE VOLTAGE OR FREQUENCY POTENTIOMETERS AS REQUIRED.

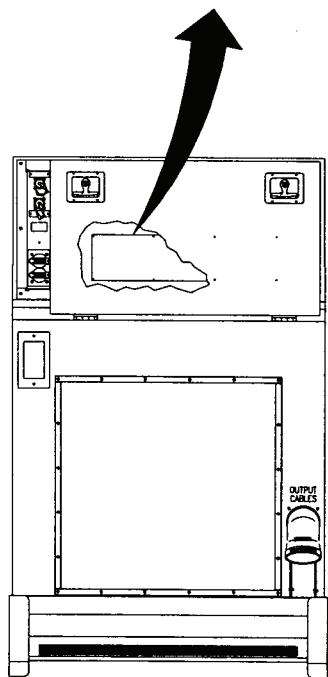

REAR

FLUIDS

OIL		FUEL		COOLANT	
AMBIENT TEMPERATURE	OIL	AMBIENT TEMPERATURE	FUEL	AMBIENT TEMPERATURE	RADIATOR COOLANT
-50°F TO 40°F	MIL-L-46167 DEA	-25°F TO 20°F	DIESEL A-A-52557 1-D	-50°F TO 120°F	A-A-52624 ANTIFREEZE
-15°F TO 40°F	MIL-PRF-2104 OE/HDO-10	20°F TO 120°F	DIESEL A-A-52557 2-D	-25°F TO 120°F	WATER WITH A-A-52624 ANTIFREEZE
15°F TO 90°F	MIL-PRF-2104 OE/HDO-30	-50°F TO 120°F	JPS MIL-PRF-5624 AND JPB MIL-T-83133	40°F TO 120°F	WATER WITH MIL-A-53009 ADDITIVE
30°F TO 120°F	MIL-PRF-2104 OE/HDO-40				
5°F TO 120°F	MIL-PRF-2104 OE/HDO-15/40				

CAPACITIES

FUEL TANK	LUBRICATING OIL (REFILL WITH FILTER CHANGE)	COOLING SYSTEM
FUEL 66 GALS	30 QTS FULL TO LOW 3 QTS	COOLANT 38 QTS

0116-1900-05

100KW-10-226D

DECALS AND INSTRUCTION PLATES – Continued

PARALLELING
 RECEPTACLES

GROUND FAULT
 CIRCUIT INTERRUPTER

120 VOLTS
 15 AMPS, 60 HZ

COOLANT HEATER OPERATING INSTRUCTIONS:

1. GROUND THE GENERATING SET.
2. SWITCH THE HEATER CONTROL SWITCH TO THE "ON" POSITION.
3. ALLOW THE HEATER TO OPERATE UNTIL THE TEMPERATURE SENSOR SWITCHES TO "LOW" HEAT OR FOR 55 MINUTES THEN FOLLOW THE GENERATOR STARTING INSTRUCTIONS.
4. AFTER STARTING THE GENERATOR, SWITCH THE HEATER CONTROL SWITCH TO THE "OFF" POSITION. THE COMBUSTION AIR BLOWER AND WATER PUMP WILL CONTINUE TO RUN FOR APPROXIMATELY 3 MIN.

NOTE:
 SWITCH THE HEATER ON FOR APPROXIMATELY 1 MIN ABOUT ONCE A MONTH DURING THE WARM SEASON TOO. THIS PREVENTS THE WATER PUMP AND BURNER MOTOR SEIZING UP.

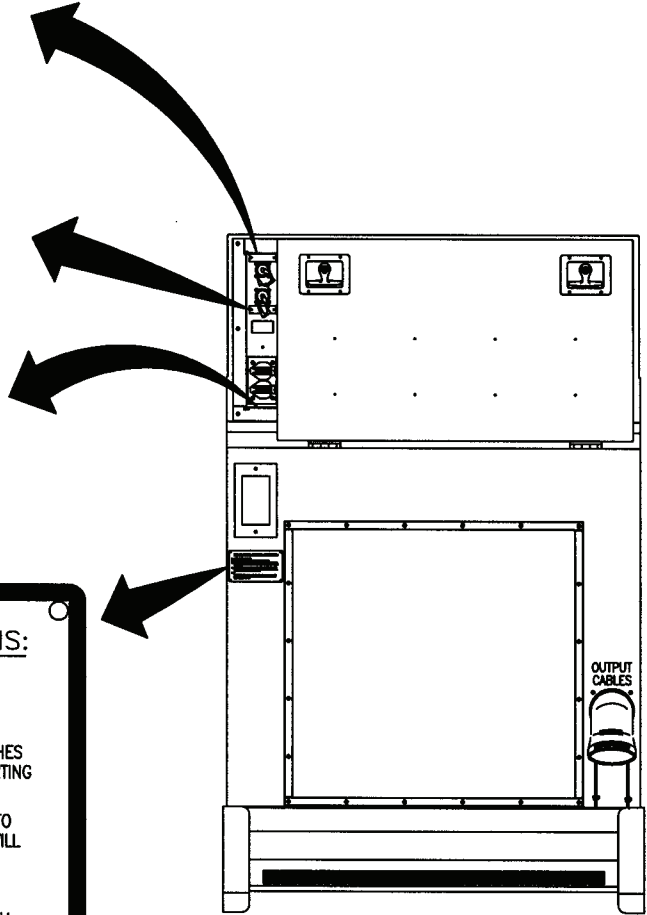

REAR

100KW-10-227B

CAUTION
HEARING PROTECTION
REQUIRED WHEN
OPERATING THE SET

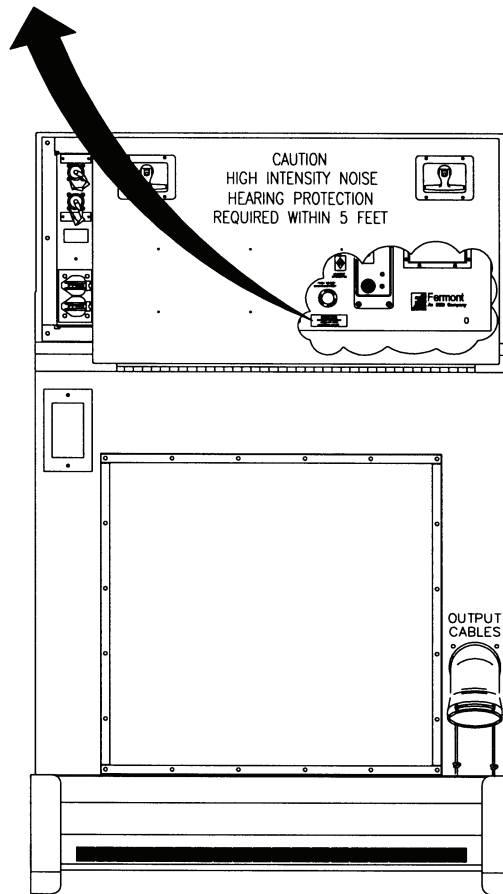

REAR WARNINGS, CAUTIONS, LABELS

100KW-10-241

END OF TASK

OPERATING AUXILIARY EQUIPMENT**Use of Convenience Receptacle**

Power is available when the main contactor is closed. Avoid accidental contact. Failure to observe this warning can result in severe personal injury or death by electrocution.

CAUTION

The maximum power rating for the convenience receptacle is 15A. To prevent circuit breaker from opening, the total current drawn should be limited to 15A only. Failure to limit the load to less than 15A may trip the circuit breaker and damage the generator set or load.

1. On EMCP, set ENGINE CONTROL switch to MANUAL START.
2. Ensure load does not exceed maximum rating of 15A.
3. If necessary, reset GFCI breaker overcurrent protection (WP 0013 00).
4. Plug appropriate connector into convenience receptacle.

END OF TASK

PREPARATION FOR MOVEMENT**WARNING**

Metal jewelry can conduct electricity and become entangled in generator set components. Remove all metal jewelry when working on generator set. Failure to comply can cause injury or death to personnel.

High voltage is produced when this generator set is in operation. Make sure unit is completely shut down and free of any power source before attempting any repair or maintenance on the unit. Failure to comply can cause injury or death to personnel.

DC voltages are present at generator set electrical components even with generator set shut down. Avoid shorting any positive with ground/negative. Failure to comply can cause injury to personnel and damage to equipment.

If necessary to move a generator set that has been operating in parallel with another generator set, shut down all generator sets prior to removing load cables or ground. Failure to comply can cause injury or death to personnel by electrocution.

Before making any connections for parallel operation or moving a generator set that has been operating in parallel, ensure there is no input to the load board and the generator sets are shut down. Failure to comply can cause injury or death to personnel by electrocution.

High voltage is produced when the generator set is in operation. Never attempt to connect or disconnect load cables while the generator set is running. Failure to comply can cause injury or death to personnel.

1. Set ENGINE CONTROL switch to OFF/RESET.
2. Perform all After PMCS requirements per WP 0012 00.
3. Open rear left housing door and set DEAD CRANK SWITCH to OFF.
4. Open battery compartment and set Battery Disconnect Switch to OFF.
5. Open output load terminal door at right rear of TQG.
6. Using terminal nut wrench (1), loosen load terminal nuts (2).
7. Disconnect all load cables (3) from output load terminals (4) and remove cables from generator set and from all paralleled generator sets if paralleled (WP 0006 00).
8. Secure wrench (1) inside load terminal door and close door.

PREPARATION FOR MOVEMENT – Continued

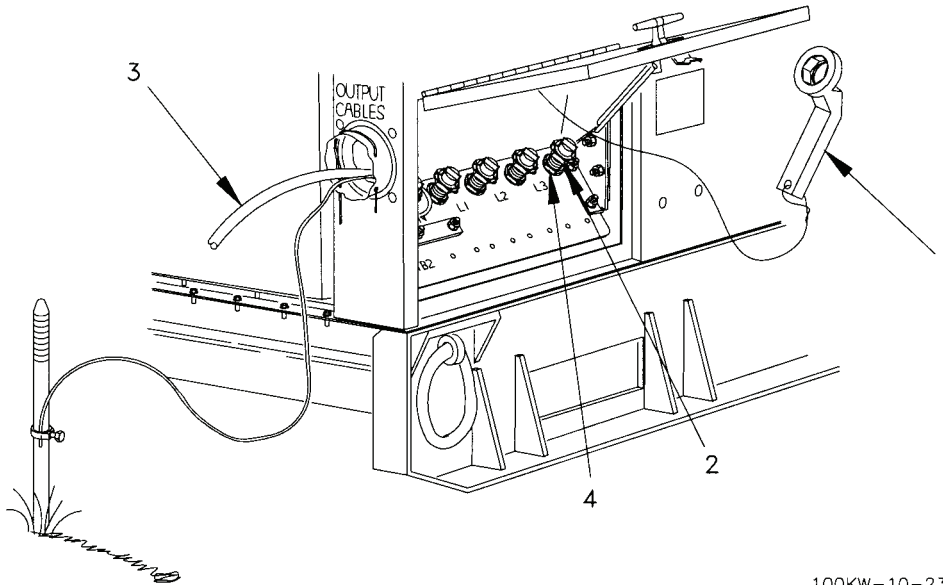

100KW-10-234A

9. Disconnect paralleling cable, if used, and store in storage box located inside battery compartment access door.
10. Disconnect ground cable (5) from ground terminal (6) and clamp (7), and remove clamp.
11. Remove ground rods (8) and couplers (9) from ground. Store ground rods in holding clips located inside generator set housing on left side. Store cable and couplers in storage box.

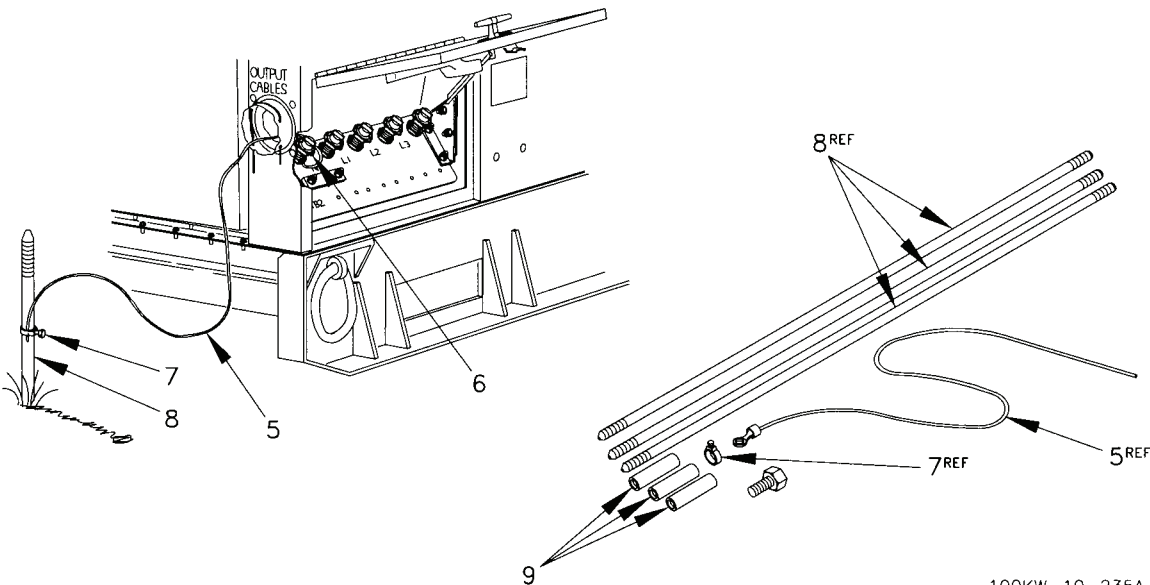

100KW-10-235A

12. Secure all generator set access doors and panels.

END OF TASK

**100 kW TACTICAL QUIET GENERATOR SET
OPERATION UNDER UNUSUAL CONDITIONS**

0007 00

THIS WORK PACKAGE COVERS:

- Operation in Extreme Cold Weather Below -25°F (-32°C)
- Operation of Winterization Kit
- Operation in Extreme Heat Above 120°F (49°C)
- Operation in Dusty or Sandy Conditions
- Operation Under Rainy or Humid Conditions
- Operation in Salt Water Areas
- Operation at High Altitudes
- Operation Using Battle Short Switch
- Operation While Contaminated (NBC)

INITIAL SETUP:

Maintenance Level

Operator

References

- FM 3-3
- FM 3-4
- FM 3-5
- WP 0006 00
- WP 0016 00

Tools and Special Tools

None

Personnel Required

One

Materials/Parts

None

OPERATION IN EXTREME COLD WEATHER BELOW -25°F (-32°C)

WARNING



In extreme cold weather, skin can stick to metal. Avoid contacting metal items with bare skin in extreme cold weather. Failure to comply can cause injury to personnel.

NOTE

If temperatures are below -25°F (-32°C) activate winterization kit approximately 30 minutes to one hour before attempting to start generator set or your generator set may not start.

The generator set can operate in temperatures as low as -50°F (-46°C). To ensure satisfactory operation under extreme cold weather the following additional steps must be taken prior to starting.

1. Keep generator set and surrounding area as free of ice and snow as practical.
2. Keep fuel tank full to protect against moisture, condensation, and accumulation of water.
3. Ensure proper grade diesel fuel is used (WP 0016 00, Table 1).
4. Keep batteries free from corrosion and in a well-charged condition.
5. If winterization kit is installed, activate and operate.

END OF TASK

OPERATION OF WINTERIZATION KIT

The winterization kit can be used at temperatures below 30°F (-1.1°C).

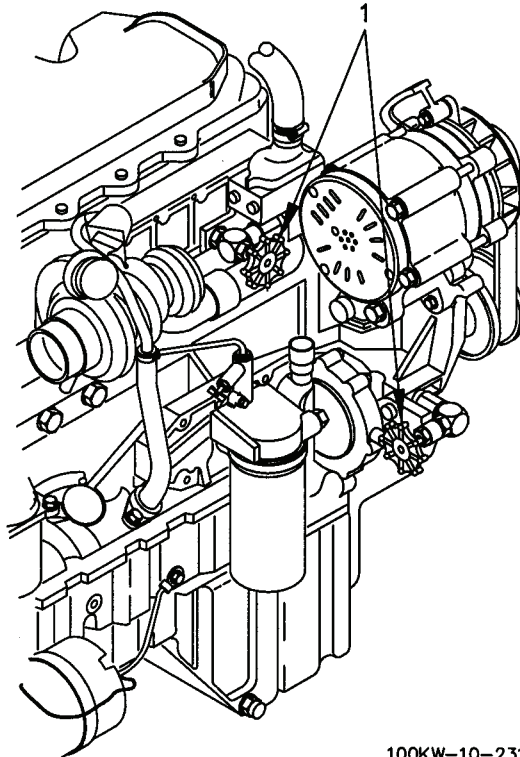

100KW-10-231A

NOTE

If temperatures are below 30°F (-1.1°C) the winterization kit may require 30 minutes to one hour to warm the engine up to starting temperature.

1. Perform INITIAL ADJUSTMENTS BEFORE USE AND SELF-TEST procedures (WP 0006 00-9).
2. Open right front access doors and verify that winterization kit coolant valves (1) are open.
3. Verify the TQG is properly grounded (WP 0006 00).
4. On winterization kit control panel, press in CIRCUIT BREAKER.
5. On FUEL FIRED HEATER CONTROL, set switch to ON to energize fuel-fired heater.
6. On EMCP set ENGINE CONTROL switch to COOL DOWN/STOP.
7. On GSC keypad press ENGINE METER key and observe coolant temperature. Generator set can be started when coolant temperature reaches 120°F (48.9°C).
8. After starting the TQG, set switch to OFF. The combustion air blower and water pump will continue to run for approximately 3 minutes.

END OF TASK

OPERATION IN EXTREME HEAT ABOVE 120°F (49°C)

CAUTION

Operating the generator set with restricted air flow for cooling can cause the generator set to overheat. Keep all access door inlet panels clear to ensure maximum air flow for engine and generator cooling. Failure to comply can result in poor engine performance and possible overheating and automatic shutdown.

1. Keep generator set doors closed to optimize engine cooling, keep the engine clean, and reduce noise.
2. Check vents and radiator air passages frequently for obstructions.
3. Check coolant temperature indicator frequently for any indication of overheating.
4. Allow sufficient space for fuel expansion when filling fuel tank (WP 0016 00).
5. Keep generator clean and free of dirt. Clean obstructions from generator intake and outlet screens.
6. Clean external surface of engine when generator set is not operating.
7. Using Table 1, determine the allowable load capacities for the 100 kW TQG for local operating temperatures. Notify maintenance to evaluate and adjust TQG loads as necessary. It may be necessary to add another TQG or to reduce the load demand.

Table 1. High Temperature Load Capacities.

AMBIENT TEMPERATURE	PERCENTAGE OF RATED LOAD
125° F (52° C)	100
130° F (54° C)	80.1
135° F (57° C)	75.5
140° F (60° C)	60.4

END OF TASK

OPERATION IN DUSTY OR SANDY CONDITIONS

1. If possible, provide a shelter for generator set. Use available natural barriers to shield generator set from blowing dust or sand.
2. Keep generator set doors closed to optimize engine cooling, keep the engine clean, and reduce noise.
3. Wet down dusty and sandy surface areas around generator set frequently if water is available.
4. Keep all access doors closed, as much as possible, to prevent entry of dust and sand into housing assembly.
5. Wipe dust and sand frequently from the generator set external surface and components. Wash exterior surfaces frequently with clean water when generator set is not operating.
6. Service engine air cleaner assembly frequently to compensate for intake of additional dust or sand (WP 0014 00).
7. Drain sediment frequently from fuel filter/water separator. When servicing fuel tank be careful to prevent dust or sand from entering fuel tank (WP 0016 00).
8. Notify maintenance to change engine oil and oil filter frequently.
9. Store oil and fuel in dust-free containers.
10. Ensure generator set ground connections are free of dust and sand and connections are tight before starting the unit.

END OF TASK

OPERATION UNDER RAINY OR HUMID CONDITIONS**CAUTION**

Failure to remove waterproof material before operating generator set could result in equipment damage.

1. If possible, provide a shelter for generator set. Cover generator set with canvas or other waterproof material when it is not being operated.
2. Provide adequate drainage to prevent water from accumulating on operation site.
3. Keep all generator set access doors closed, as much as possible, to prevent entry of water into housing assembly.
4. Drain water frequently from fuel filter/water separator (WP 0016 00).

WARNING

High voltage is produced when this generator set is in operation. Make sure unit is completely shut down and free of any power source before attempting any repair or maintenance on the unit. Failure to comply can cause injury or death to personnel.

High voltage is produced when the generator set is in operation. Never attempt to start the generator set unless it is properly grounded. Failure to comply can cause injury or death to personnel.

DC voltages are present at generator set electrical components even with generator set shut down. Avoid shorting any positive with ground/negative. Failure to comply can cause injury to personnel and damage to equipment.

5. Remove moisture from generator set components before and after each operating period.
6. Keep fuel tank full to protect against moisture, condensation and accumulation of water.

END OF TASK**OPERATION IN SALT WATER AREAS****CAUTION**

Failure to remove waterproof material before operating generator set could result in equipment damage.

1. If possible, provide a shelter for the generator set. Locate generator set so that radiator faces into prevailing winds. Use natural barriers or, if possible, construct a barrier to protect generator set from salt water. Cover generator set with canvas or other waterproof material when it is not being operated.
2. Keep all generator access doors closed, as much as possible, to prevent entry of salt water into housing assembly.
3. Wash exterior surfaces frequently with clean water when generator set is not operating.
4. Check wiring connections for corrosion and wire insulation for signs of deterioration.

END OF TASK

**100 kW TACTICAL QUIET GENERATOR SET
OPERATION UNDER UNUSUAL CONDITIONS – Continued**

0007 00

OPERATION AT HIGH ALTITUDES

Generator set will operate at elevations up to 4,000 feet (1219.1m) above sea level without special adjustment or reduction in load. At elevations greater than 4,000 feet (1219.1m) above sea level, kilowatt rating is reduced approximately 3.5 percent for each additional 1,000 feet (304.8m).

END OF TASK**OPERATION USING BATTLE SHORT SWITCH****CAUTION**

Continued operation using the BATTLE SHORT switch can result in damage to the generator set.

NOTE

If any emergency situation requires continued operation of the generator set, the BATTLE SHORT switch is used to override all protection devices except the overspeed, short circuit devices, and EMERGENCY STOP function.

BATTLE SHORT switch must be OFF to start generator set.

1. On EMCP, set BATTLE SHORT switch to OFF.
2. Set ENGINE CONTROL switch to MANUAL START.
3. Once generator set starts, lift cover on BATTLE SHORT switch and set to ON.

END OF TASK**OPERATION WHILE CONTAMINATED (NBC)**

Generator set will operate in a normal manner when exposed to nuclear, biological, or chemical (NBC) contamination. It is capable of being operated by personnel wearing NBC clothing without special tools or support equipment. Refer to FM 3-3, FM 3-4, and FM 3-5.

END OF TASK

CHAPTER 3
OPERATOR TROUBLESHOOTING PROCEDURES
FOR
100 kW TACTICAL QUIET GENERATOR SET

CHAPTER 3

OPERATOR TROUBLESHOOTING PROCEDURES FOR 100 kW TACTICAL QUIET GENERATOR SET

WORK PACKAGE INDEX

<u>Title</u>	<u>WP Sequence No.</u>
INTRODUCTION	0008 00
MALFUNCTION/SYMPTOM INDEX.....	0009 00
TROUBLESHOOTING PROCEDURES.....	0010 00

MALFUNCTION/SYMPTOM INDEX

The troubleshooting Malfunction/Symptom Index (WP 0009 00) lists common malfunctions found during operation or crew servicing of the 100 kW TQG. In addition, it lists all of the fault codes that will be displayed on the Generator Set Control (GSC). Use the Malfunction/Symptom index to identify the malfunction/symptom that best describes your problem and then follow the instructions in the Work Package and Page No. column for the troubleshooting that you can do. These will refer you to the Troubleshooting Procedures (WP 0010 00). In WP 0010 00 follow each step in sequence through the test or inspections listed in the Troubleshooting Procedures Table until a fault is identified. Most of the listings in the Malfunction/Symptom index are keyed to Fault Codes that are described in WP 0009 00 and in the brief descriptions below.

Dedicated Fault Indicators

The Malfunction/Symptom index begins with procedures to use for troubleshooting the dedicated fault indicators on the GSC. These are the lights and alarms that will tell you what problems are occurring that you can usually troubleshoot.

GSC Alarm Fault Codes

The GSC Alarm Fault Codes are a set of fault codes displayed in the upper display on the EMCP. These are engine fault codes, protective relay function codes, and paralleling fault codes. They rely on programmed setpoints, but you can do some troubleshooting that will correct the problems.

Generator Set Control (GSC) SP Fault Codes

These special codes are monitored by the GSC. The operator can troubleshoot the low fuel level fault (SP1), but maintenance must be notified for the codes associated with paralleling the TQG.

Digital Voltage Regulator (DVR) Alarm Fault Codes

When errors in the operation of the TQG output and voltage regulation are detected, these codes are displayed. Record DVR alarm codes and notify maintenance when DVR Fault Codes are displayed.

Generator Set Control (GSC) Fault Codes, including Engine Control Module (ECM) Codes and Event Codes

The GSC Fault codes are displayed on the upper display when faults are detected in the operation of the engine or of the TQG. Sometimes they are displayed along with the Dedicated Shutdown Indicators and your troubleshooting will correct the faults and they will not return. Some of the codes are Event Codes that simply announce a condition of the engine or the TQG that needs attention. You can notify maintenance when these fault codes appear on the GSC. The GSC Fault Codes consist of a component identification (CID) number followed by a Fault Mode Identification (FMI). If the code originates with the Engine Control Module (ECM), the CID will be followed by an E before the FMI code. The meaning of the CID FMI codes are given in the Malfunction/Symptom Index. When you see these codes, record them and notify maintenance.

TROUBLESHOOTING PROCEDURES



Metal jewelry can conduct electricity and become entangled in generator set components. Remove all metal jewelry when working on generator set. Failure to comply can cause injury or death to personnel.

High voltage is produced when this generator set is in operation. Make sure unit is completely shut down and free of any power source before attempting any repair or maintenance on the unit. Failure to comply can cause injury or death to personnel.

High voltage is produced when the generator set is in operation. Never attempt to start the generator set unless it is properly grounded. Failure to comply can cause injury or death to personnel.

DC voltages are present at generator set electrical components even with generator set shut down. Avoid shorting any positive with ground/negative. Failure to comply can cause injury to personnel and damage to equipment.

The Troubleshooting Procedures (WP 0010 00) contain a table that lists the malfunctions, tests or inspections, and corrective actions required to return the TQG to normal operation. The operator troubleshooting procedures cannot list all possible malfunctions or tests and inspections required for corrective action. If a malfunction is not listed or is not corrected by the listed corrective actions, notify maintenance immediately.

The WP 0010 00 INITIAL SETUP outlines what is needed for the task as well as certain conditions that must be met before starting the task. Don't start a task until the following conditions exist:

1. You understand the task.
2. You understand what you are to do.
3. You understand what is needed to do the work.
4. You have the things you need.

WP 0010 00 Troubleshooting Table 1 has three columns: MALFUNCTION, TEST OR INSPECTION, and CORRECTIVE ACTION. Note that the malfunctions are also listed in the Malfunction/Symptom Index (WP 0009 00).

MALFUNCTIONs are numbered in sequence and are to be performed in the order in which they appear.

TESTs OR INSPECTIONs are steps you take to isolate the malfunction. Each test or inspection has a corrective action. These are the "if" statements that tell you what to do when the malfunction is not fixed.

CORRECTIVE ACTIONs are actions intended to correct the problem. If the problem cannot be identified or corrected, report the problem as follows: (US Army) report all deficiencies, including deficiencies that appear to involve unsatisfactory design, on DA Form 5988-E, automated form in the Unit Level Logistics System (ULLS), generated Equipment Maintenance and Inspection Worksheet. When no automation is available, use DA Form 2404 (Equipment Inspection and Maintenance Worksheet). Both forms serve the same purpose. Air Force and Marine Corps report all deficiencies on SF Form 368.

**100 kW TACTICAL QUIET GENERATOR SET
MALFUNCTION/SYMPTOM INDEX – Continued**

The Malfunction/Symptom Index provides a quick reference by work package number and page number for error messages and troubleshooting procedure malfunctions.

<u>Malfunction/Symptom</u>	<u>Work Package and Page No.</u>
Dedicated Fault Indicators	
1. EMCP AC CIRCUIT INTERRUPTER lamp does not light when TQG is connected to load.	0010 00-3
2. EMCP panel lamp is not lit.	0010 00-3
3. GSC LOW OIL PRESSURE red indicator flashes.	0010 00-3
4. GSC HIGH WATER TEMP red indicator flashes.	0010 00-4
5. GSC LOW COOLANT LEVEL red indicator flashes.	0010 00-5
6. Alarm module OVERCURRENT amber indicator flashes. TQG disconnects from load.	0010 00-5
7. Alarm module GENERATOR OVERLOAD amber indicator flashes. TQG disconnects from load.	0010 00-6
8. Alarm module LOW FUEL LEVEL red indicator glows steady. TQG engine shuts down.	0010 00-7
9. Convenience receptacle on PARALLELING RECEPTACLES panel has no power.	0010 00-8
10. Winterization kit (issued to selected units only) is not operating. DIAGNOSTIC light is red.	0010 00-8
GSC Alarm Fault Codes	
11. AL1 - High Water Temperature	Troubleshoot as Malfunction 4, 0010 00-4.
12. AL2 - Low Water Temperature	AL2 can be a transient code that will go away after the TQG is running. If not, notify maintenance.
13. AL3 - Low Engine Oil Pressure	Troubleshoot as Malfunction 3, 0010 00-3.
14. AL4 - Fault Detected by Engine ECM	Notify maintenance.
15. AL5 - Low Engine Coolant Level	Troubleshoot as Malfunction 5, 0010 00-4
16. AL6 - High Engine Oil Temperature	Troubleshoot as Malfunction 3, 0010 00-3. Notify maintenance.
17. AL7- Generator Over Voltage	Notify maintenance.
18. AL8 - Generator Under Voltage	Notify maintenance.

**100 kW TACTICAL QUIET GENERATOR SET
MALFUNCTION/SYMPTOM INDEX – Continued**

<u>Malfunction/Symptom</u>		<u>Work Package and Page No.</u>
19.	AL9 - Generator Over Frequency	Notify maintenance.
20.	AL10 - Generator Under Frequency	Notify maintenance.
21.	AL11 - Generator Reverse Power	Notify maintenance.
22.	AL12 - Phase Over Current	Notify maintenance.
23.	AL13 - Generator Total Over Current	Notify maintenance.
24.	AL14 - Phase A No Voltage Input	Notify maintenance.
25.	AL15 - GSC Configuration Error	Notify maintenance.
26.	AL16 - Incorrect Phase Sequence	Notify maintenance.
27.	AL17- Improper Generator or Bus Voltage	Notify maintenance.
28.	AL18 - Synchronizer Time-out	Notify maintenance.
GSC SP Fault Codes		
29.	SP1 - Low Fuel Level	Troubleshoot as Malfunction 8, 0010 00-7.
30.	SP2 – DVR fault	Notify maintenance.
31.	SP3 - When relay K1 is energized and one or both of the following is true for more than 2 seconds an SP3 fault is announced: The difference in frequency between the generator and the bus is greater than 0.2 Hz. The difference in phase between the generator and the bus is greater than 10 degrees. The GSC will then stop the synchronization process until the fault is cleared and corrected.	Notify maintenance.
32.	SP4 - Input is active when 208 or 416 VAC is detected on the load bus by relay DBLO or DBHI. This input is compared to the reading of the bus voltage (P7-17 and P7-18). If the voltage of phase A is less than 20% of the rated voltage, it is considered to be “dead”. If the condition of these measurements is different with regards to presence or absence of bus voltage, a fault is announced.	Notify maintenance.
DVR Alarm Fault Codes		
33.	601 - Internal Memory Failure Alarm	Notify maintenance.
34.	602 - Internal Watchdog Failure Alarm	Notify maintenance.
35.	603 - Rotating Diode Failure Alarm	Notify maintenance.
36.	604 – Reverse VAR Alarm	Notify maintenance.
37.	701 – Undervoltage Shutdown	Notify maintenance.

**100 kW TACTICAL QUIET GENERATOR SET
MALFUNCTION/SYMPTOM INDEX – Continued**

<u>Malfunction/Symptom</u>		<u>Work Package and Page No.</u>
38.	702 - Overvoltage Shutdown	Notify maintenance.
39.	703 - Overexcitation Shutdown	Notify maintenance.
40.	704 – Reverse VAR Shutdown	Notify maintenance.
51.	705 – Reverse Power Shutdown	Notify maintenance.
52.	801 – Instantaneous Trip Shutdown	Notify maintenance.
53.	802 – Loss of Sensing Shutdown	Notify maintenance.
54.	803 – Loss of Frequency Shutdown	Notify maintenance.
55.	9xx - Severe Fault. There are several possible failures in the 900's. All require replacement of the DVR.	Notify maintenance.
GSC Fault Codes, including Engine Control Module (ECM) Codes and Event Codes (CID Number Sequence)		
56.	CID 1 E FMI 11 Cylinder 1 Failure mode is not identifiable (Mechanical Failure) (Logged)	Notify maintenance.
57.	CID 2 E FMI 11 Cylinder 2 Failure mode is not identifiable (Mechanical Failure) (Logged)	Notify maintenance.
58.	CID 3 E FMI 11 Cylinder 3 Failure mode is not identifiable (Mechanical Failure) (Logged)	Notify maintenance.
59.	CID 4 E FMI 11 Cylinder 4 Failure mode is not identifiable (Mechanical Failure) (Logged)	Notify maintenance.
60.	CID 5 E FMI 11 Cylinder 5 Failure mode is not identifiable (Mechanical Failure) (Logged)	Notify maintenance.
61.	CID 6 E FMI 11 Cylinder 6 Failure mode is not identifiable (Mechanical Failure) (Logged)	Notify maintenance.
62.	CID 9 E FMI 02 High Altitude Derate (Active Only)	Notify maintenance.
63.	CID 41 E FMI 03 Above normal 8 Volt Power Supply Failure mode is not identifiable (Mechanical Failure) (Logged) (8 volt supply not used)	Not used for this TQG.
64.	CID 41 E FMI 04 Below normal 8 Volt Power Supply Failure mode is not identifiable (Mechanical Failure) (Logged) (8 volt supply not used)	Not used for this TQG.
65.	CID 42 E FMI 11 Injection Actuator Pressure Valve Failure mode is not identifiable (Mechanical Failure) (Logged)	Notify maintenance.
66.	CID 85 E FMI 01 Shutdown Overridden (Logged Only)	Notify maintenance.
67.	CID 91 E FMI 08 PWM Throttle Position Sensor Abnormal frequency, pulse width, or period (Not Logged)	Notify maintenance.
68.	CID 94 E FMI 03 Fuel Pressure Sensor Voltage above normal (Logged)	Notify maintenance.
69.	CID 94 E FMI 04 Fuel Pressure Sensor Voltage data is valid but below normal operating mode (Logged)	Notify maintenance.

**100 kW TACTICAL QUIET GENERATOR SET
MALFUNCTION/SYMPTOM INDEX – Continued**

0009 00

<u>Malfunction/Symptom</u>		<u>Work Package and Page No.</u>
70.	CID 96 E FMI 01 High Fuel Pressure Warning (Active and Logged)	Notify maintenance.
71.	CID 97 E FMI 01 Derate Overridden (Logged Only)	Notify maintenance.
72.	CID 100 E FMI 02 Engine Oil Pressure Sensor Erratic, intermittent, or incorrect signal (Logged)	Notify maintenance.
73.	CID 100 E FMI 03 Engine Oil Pressure Sensor Voltage above normal (Logged)	Notify maintenance.
74.	CID 100 E FMI 04 Engine Oil Pressure Sensor Voltage below normal (Logged)	Notify maintenance.
75.	CID 110 FMI 02 Engine Coolant Temperature Sensor Erratic, intermittent, or incorrect signal (Logged)	Notify maintenance.
76.	CID 110 FMI 03 Engine Coolant Temperature Sensor Voltage above normal (Logged)	Notify maintenance.
77.	CID 110 FMI 04 Engine Coolant Temperature Sensor Voltage below normal (Logged)	Notify maintenance.
78.	CID 111 FMI 03 Engine Low Coolant Sensor Voltage above normal	Notify maintenance.
79.	CID 164 E FMI 00 Injection Actuation Pressure System Data is Valid but Above Normal Operating Range (Logged)	Notify maintenance.
80.	CID 164 E FMI 11 Injection Actuation Pressure System Failure Mode is Not Identifiable (Logged)	Notify maintenance.
81.	CID 164 E FMI 02 Injection Actuation Pressure System Erratic, Intermittent, or Incorrect Signal (Logged)	Notify maintenance.
82.	CID 164 E FMI 03 Injection Actuation Pressure System Voltage Above Normal (Logged)	Notify maintenance.
83.	CID 164 E FMI 04 Injection Actuation Pressure System Voltage Below Normal (Logged)	Notify maintenance.
84.	CID 168 E FMI 02 Electrical System Voltage Erratic, intermittent	Notify maintenance.
85.	CID 168 E FMI 03 Electrical System Voltage Above Normal	Notify maintenance.
86.	CID 168 E FMI 04 Electrical System Voltage Below Normal	Notify maintenance.
87.	CID 169 E FMI 01 Engine Oil Maintenance Required	Notify maintenance.
88.	CID 170 E FMI 01 Fuel Filter Change Required	Notify maintenance.
89.	CID 172 E FMI 03 Inlet Air Temperature Sensor Data is Valid but Above Normal Operating Range (Logged)	Notify maintenance.
90.	CID 172 E FMI 04 Inlet Air Temperature Sensor Failure Data is Valid but Below Normal Operating Range (Logged)	Notify maintenance.
91.	CID 175 E FMI 02 Engine Oil Temperature Sensor Erratic, Intermittent, or Incorrect Signal (Logged)	Notify maintenance.

**100 kW TACTICAL QUIET GENERATOR SET
MALFUNCTION/SYMPTOM INDEX – Continued**

<u>Malfunction/Symptom</u>		<u>Work Package and Page No.</u>
92.	CID 175 E FMI 03 Engine Oil Temperature Sensor Data is Valid but Above Normal Operating Range (Logged)	Notify maintenance.
93.	CID 175 E FMI 04 Engine Oil Temperature Sensor Data is Valid but Below Normal Operating Range (Logged)	Notify maintenance.
94.	CID 190 FMI 02 Magnetic Pickup Unit Erratic, Intermittent, or Incorrect Signal (Logged)	Notify maintenance.
95.	CID 190 FMI 03 Magnetic Pickup Unit Voltage Above Normal (Logged)	Notify maintenance.
96.	CID 190 E FMI 02 Primary Engine Speed/Timing Sensor Erratic, Intermittent, or Incorrect Signal (Logged)	Notify maintenance.
97.	CID 190 E FMI 11 Primary Engine Speed/Timing Sensor Failure mode not identifiable (Mechanical Failure) (Logged)	Notify maintenance.
98.	CID 248 FMI 09 CAT Data Link Abnormal Update	Notify maintenance.
99.	CID 253 E FMI 02 Personality Module Erratic, Intermittent, or Incorrect Signal	Notify maintenance.
100.	CID 254 E FMI 12 Engine Control Module Self Test Failed Component	Notify maintenance.
101.	CID 261 E FMI 13 Engine Timing (cal) Device is not calibrated	Notify maintenance.
102.	CID 262 E FMI 03 5 Volt Sensor Power Supply Voltage Above Normal	Notify maintenance.
103.	CID 262 E FMI 04 5 Volt Sensor Power Supply Voltage Below Normal	Notify maintenance.
104.	CID 264 E FMI 03 E-Stop Shutdown (Active Only)	Notify maintenance.
105.	CID 268 FMI 02 GSC Electronic Control Erratic, Intermittent, or Incorrect Signal	Notify maintenance.
106.	CID 269 FMI 03 GSC 8V Sensor Power Supply Voltage Above Normal	Notify maintenance.
107.	CID 269 FMI 04 GSC 8V Sensor Power Supply Voltage Below Normal	Notify maintenance.
108.	CID 273 FMI 03 Turbo Outlet Pressure Sensor Voltage Above Normal	Notify maintenance.
109.	CID 273 FMI 04 Turbo Outlet Pressure Sensor Voltage Below Normal	Notify maintenance.
110.	CID 274 FMI 03 Atmospheric Pressure Sensor Voltage Above Normal	Notify maintenance.
111.	CID 274 FMI 04 Atmospheric Pressure Sensor Voltage Below Normal	Notify maintenance.
112.	CID 334 FMI 03 Spare Output (P7-36) Voltage Above Normal	Notify maintenance.
113.	CID 334 FMI 04 Spare Output (P7-36) Voltage Below Normal	Notify maintenance.
114.	CID 336 E FMI 02 Engine Control Switch Erratic, Intermittent, or Incorrect Signal	Notify maintenance.
115.	CID 342 E FMI 02 Secondary Engine Speed/Timing Sensor Erratic, Intermittent, or Incorrect Signal (Logged)	Notify maintenance.
116.	CID 342 E FMI 11 Secondary Engine Speed/Timing Sensor Failure mode is not identifiable (Mechanical Failure) (Logged)	Notify maintenance.

**100 kW TACTICAL QUIET GENERATOR SET
MALFUNCTION/SYMPTOM INDEX – Continued**

0009 00

<u>Malfunction/Symptom</u>		<u>Work Package and Page No.</u>
117.	CID 360 E FMI 01 Low Engine Oil Pressure Warning (Active and Logged)	Notify maintenance.
118.	CID 360 E FMI 02 Low Engine Oil Pressure Derate (Active and Logged)	Notify maintenance.
119.	CID 360 E FMI 03 Low Engine Oil Pressure Shutdown (Active and Logged)	Notify maintenance.
120.	CID 361 E FMI 01 High Engine Coolant Temperature (Active and Logged)	Notify maintenance.
121.	CID 361 E FMI 02 High Engine Coolant Derate (Active and Logged)	Notify maintenance.
122.	CID 361 E FMI 03 High Engine Coolant Shutdown (Active and Logged)	Notify maintenance.
123.	CID 362 E FMI 01 Overspeed Warning (Active and Logged)	Notify maintenance.
124.	CID 362 E FMI 03 Overspeed Shutdown (Active and Logged)	Notify maintenance.
125.	CID 368 E FMI 01 High Inlet Air Temperature Warning (Active and Logged)	Notify maintenance.
126.	CID 390 E FMI 01 Fuel Filter Restriction Warning (Active and Logged)	Notify maintenance.
127.	CID 391 E FMI 01 Inlet Air Restriction Warning (Active and Logged)	Notify maintenance.
128.	CID 441 FMI 12 GSC Electronic Governor Relay (A1K1) Failed Component	Notify maintenance.
129.	CID 442 FMI 12 GSC Generator Fault Relay (A1K2) Failed Component	Notify maintenance.
130.	CID 443 FMI 12 GSC Crank Termination Relay (A1K3) Output (External contacts not used) Failed Component	Notify maintenance.
131.	CID 444 FMI 12 GSC Starting Motor Relay (A1K4) Failed Component	Notify maintenance.
132.	CID 445 FMI 12 GSC Run Relay (A1K5) Failed Component	Notify maintenance.
133.	CID 446 FMI 12 GSC Air Shutoff Relay Failed Component (Note: Relay not used)	Notify maintenance.
134.	CID 447 FMI 12 GSC Fuel Control Relay (A1K7) Output (External contacts not used) Failed Component	Notify maintenance.
135.	CID 448 FMI 12 GSC Programmable Spare Relay (A1K8) Failed Component	Notify maintenance.
136.	CID 500 FMI 12 GSC Failed Component	Notify maintenance.
137.	CID 566 FMI 07 Unexpected Shutdown Improper Mechanical Response	Notify maintenance.
138.	CID 590 FMI 09 Engine Electronic Control Abnormal Update	Notify maintenance.
139.	CID 617 E FMI 05 Intake Air Heater Current is below normal or circuit is open	Notify maintenance.
140.	CID 617 E FMI 06 Intake Air Heater Current is above normal or circuit is open	Notify maintenance.

**100 kW TACTICAL QUIET GENERATOR SET
MALFUNCTION/SYMPTOM INDEX – Continued**

<u>Malfunction/Symptom</u>		<u>Work Package and Page No.</u>
141.	CID 770 FMI 09 Customer Communication Module (Not used) Abnormal Update	Notify maintenance.
142.	CID 858 FMI 03 Close Breaker Output Voltage Above Normal	Notify maintenance.
143.	CID 858 FMI 04 Close Breaker Output Voltage Below Normal	Notify maintenance.
144.	CID 1038 FMI 03 Speed Adjust 1 Output Voltage Above Normal	Notify maintenance.
145.	CID 1038 FMI 04 Speed Adjust 1 Output Voltage Below Normal	Notify maintenance.
146.	CID 1167 FMI 04 K1 Sense Input (P7-25) Voltage Below Normal	Notify maintenance.
147.	CID 1168 FMI 03 Dead Bus Sensor Voltage Above Normal	Notify maintenance.
148.	CID 1168 FMI 04 Dead Bus Sensor Voltage Below Normal	Notify maintenance.
149.	CID 1169 FMI 02 AC Transformer Box (ATB) Sensor Erratic, Intermittent, or Incorrect Signal	Notify maintenance.
150.	CID 1170 FMI 02 Bus Transformer Box (BTB) Sensor Erratic, Intermittent, or Incorrect Signal	Notify maintenance.
151.	CID 1170 FMI 04 Bus Transformer Box (BTB) Sensor Voltage Below Normal	Notify maintenance.
152.	CID 1170 FMI 08 Bus Transformer Box (BTB) Sensor Abnormal frequency, pulse width, or period	Notify maintenance.
153.	CID 1589 E FMI 03 Turbocharger Air Inlet Pressure Sensor Voltage Above Normal	Notify maintenance.
154.	CID 1589 E FMI 04 Turbocharger Air Inlet Pressure Sensor Voltage Below Normal	Notify maintenance.

**100 kW TACTICAL QUIET GENERATOR SET
TROUBLESHOOTING PROCEDURES**

0010 00

THIS WORK PACKAGE COVERS:

Troubleshooting

INITIAL SETUP:

Maintenance Level
Operator

Tools and Special Tools
None

Personnel Required
One

References
WP 0006 00
WP 0013 00
WP 0015 00
WP 0016 00
WP 0017 00

Materials/Parts
None

Equipment Condition
Operating

WARNING



Metal jewelry can conduct electricity and become entangled in generator set components. Remove all metal jewelry when working on generator set. Failure to comply can cause injury or death to personnel.

High voltage is produced when this generator set is in operation. Make sure unit is completely shut down and free of any power source before attempting any repair or maintenance on the unit. Failure to comply can cause injury or death to personnel.

DC voltages are present at generator set electrical components even with generator set shut down. Avoid shorting any positive with ground/negative. Failure to comply can cause injury to personnel and damage to equipment.

WARNING



Cooling system operates at high temperature and pressure. Contact with high pressure steam and/or liquids can result in burns and scalding. Shut down generator set, and allow system to cool before performing checks, services and maintenance. Failure to comply can cause injury or death to personnel.

WARNING



When running, generator set engine has hot metal surfaces that will burn flesh on contact. Shut down generator set, and allow engine to cool before checks, services and maintenance. Wear gloves and additional protective clothing as required. Failure to comply can cause injury or death to personnel.

WARNING

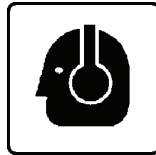

Operating the generator set exposes personnel to a high noise level. Hearing protection must be worn when operating or working near the generator set when the generator set is running. Failure to comply can cause hearing damage to personnel.

TROUBLESHOOTING

Table 1. Operator Troubleshooting.

MALFUNCTION	TEST OR INSPECTION	CORRECTIVE ACTION
<ol style="list-style-type: none"> 1. EMCP AC CIRCUIT INTERRUPTER lamp does not light when TQG is connected to load. 2. EMCP panel lamp is not lit. 	<p>Press AC CIRCUIT INTERRUPTER press-to-test lamp.</p> <ol style="list-style-type: none"> 1. Open EMCP door and inspect wiring to lamps for loose connections or damaged wires. 2. If wiring is not broken, perform CORRECTIVE ACTION. 	<ol style="list-style-type: none"> 1. If AC INTERRUPTER press-to-test lamp does not light, replace light bulb (WP 0013 00). 2. If AC INTERRUPTER press-to-test lamp lights, notify maintenance. <p>If wiring is loose or broken, notify maintenance.</p> <ol style="list-style-type: none"> 1. Replace lamp (WP 0013 00). 2. If replacing lamp does not correct problem, notify maintenance.
<p><u>WARNING</u></p> <p>Operating the generator set exposes personnel to a high noise level. Hearing protection must be worn when operating or working near the generator set when the generator set is running. Failure to comply can cause hearing damage to personnel.</p>		
<p><u>CAUTION</u></p> <p>The dipstick is marked so that the crankcase oil can be checked while engine is stopped or running. Always make sure dipstick is checked. Remove oil filler cap when checking oil with engine running.</p>		
<ol style="list-style-type: none"> 3. GSC LOW OIL PRESSURE red indicator flashes. 	<ol style="list-style-type: none"> 1. Set ENGINE CONTROL switch to COOL DOWN/STOP. 2. Set DEAD CRANK SWITCH to OFF. 3. Set Battery Disconnect Switch to OFF. 4. After engine stops, check oil level per WP 0017 00. 	<ol style="list-style-type: none"> 1. If oil is below ADD mark, fill as required per WP 0017 00. 2. If oil level is correct or problem continues, notify maintenance.

Table 1. Operator Troubleshooting - Continued

MALFUNCTION	TEST OR INSPECTION	CORRECTIVE ACTION
<p><u>WARNING</u></p>		
<p>Cooling system operates at high temperature and pressure. Contact with high pressure steam and/or liquids can result in burns and scalding. Shut down generator set, and allow system to cool before performing checks, services and maintenance. Failure to comply can cause injury or death to personnel.</p>		
<p><u>WARNING</u></p>		
<p>Operating the generator set exposes personnel to a high noise level. Hearing protection must be worn when operating or working near the generator set when the generator set is running. Failure to comply can cause hearing damage to personnel.</p>		
<p><u>CAUTION</u></p>		
<p>Operating the generator set with restricted airflow for cooling can cause the generator set to overheat. Keep all access door inlet panels clear to ensure maximum airflow for engine and generator cooling. Failure to comply can result in poor engine performance and possible overheating and automatic shutdown.</p>		
<p>4. GSC HIGH WATER TEMP red indicator flashes.</p>	<ol style="list-style-type: none"> 1. Set ENGINE CONTROL switch to COOL DOWN/STOP. 2. Set DEAD CRANK SWITCH to OFF. 3. Set Battery Disconnect Switch to OFF. 4. Allow engine to cool. 5. Inspect water level in coolant overflow bottle per WP 0015 00. 6. Visually inspect radiator and coolant system for damage, leaks, loose clamps, fan guards, fan, and shrouds or obstructions per WP 0015 00. 7. Visually inspect engine for missing or loose fan belt. 	<ol style="list-style-type: none"> 1. If coolant level is low, refill coolant overflow bottle with correct mixture of water and coolant per WP 0015 00. 2. Monitor coolant level and refill as required per WP 0015 00. <p>Remove obstructions and debris from fan guards and shroud area, tighten clamps. If radiator is obstructed and coolant system damaged or you cannot tighten clamps, notify maintenance.</p> <p>If fan belt is missing or loose, notify maintenance to tighten or replace belt.</p>

Table 1. Operator Troubleshooting - Continued

MALFUNCTION	TEST OR INSPECTION	CORRECTIVE ACTION
<p>5. GSC LOW COOLANT LEVEL red indicator flashes.</p>	<ol style="list-style-type: none"> 1. Set ENGINE CONTROL switch to COOL DOWN/STOP. 2. Set DEAD CRANK SWITCH to OFF. 3. Set Battery Disconnect Switch to OFF. 4. Allow engine to cool. 5. Check coolant level in coolant overflow bottle per WP 0015 00. 6. Visually inspect radiator and coolant system for damage, leaks, loose clamps, fan guards, fan, and shrouds or obstructions per WP 0015 00. 	<ol style="list-style-type: none"> 1. If coolant level is low, refill coolant overflow bottle with correct mixture of water and coolant per WP 0015 00. 2. Monitor coolant level and refill as required. <p>Remove obstructions and debris from fan guards and shroud area, tighten clamps. If radiator is obstructed and coolant system damaged or you cannot tighten clamps, notify maintenance.</p>
<p><u>WARNING</u></p>		
<p>Metal jewelry can conduct electricity and become entangled in generator set components. Remove all metal jewelry when working on generator set. Failure to comply can cause injury or death to personnel.</p>		
<p>High voltage is produced when this generator set is in operation. Make sure unit is completely shut down and free of any power source before attempting any repair or maintenance on the unit. Failure to comply can cause injury or death to personnel.</p>		
<p>DC voltages are present at generator set electrical components even with generator set shut down. Avoid shorting any positive with ground/negative. Failure to comply can cause injury to personnel and damage to equipment.</p>		
<p>6. Alarm module OVERCURRENT amber indicator flashes. TQG disconnects from load.</p>	<ol style="list-style-type: none"> 1. Set ENGINE CONTROL switch to OFF/RESET. 2. Set DEAD CRANK SWITCH to OFF. 3. Set Battery Disconnect Switch to OFF. 	

Table 1. Operator Troubleshooting – Continued.

MALFUNCTION	TEST OR INSPECTION	CORRECTIVE ACTION
<p>6. Alarm module OVERCURRENT amber indicator flashes. TQG disconnects from load. – Continued</p>	<p>4. Check load connected to TQG to see if there was a problem there that could cause TQG to go overcurrent. Inspect cables to load for shorts, broken insulation, exposed wires, signs of overheating, melted conductors, or failed components.</p> <p>5. Determine if load is too large for generator set. (Power requirement cannot be larger than TQG rating.)</p> <p>6. Set Battery Disconnect Switch to ON.</p> <p>7. Set DEAD CRANK SWITCH to NORMAL.</p> <p>8. Set ENGINE CONTROL switch to STOP COOL/DOWN.</p> <p>9. Press LAMP TEST on alarm module to reset overload fault detection circuit.</p> <p>10. Start and operate TQG (WP 0006 00-11)</p>	<p>Repair cause of overcurrent or notify maintenance.</p> <p>Reduce load as necessary.</p> <p>1. Monitor TQG for further problems.</p> <p>2. If there is no identifiable problem with the load and alarm recurs, notify maintenance.</p>
<p><u>WARNING</u></p>		
<p>Metal jewelry can conduct electricity and become entangled in generator set components. Remove all metal jewelry when working on generator set. Failure to comply can cause injury or death to personnel.</p>		
<p>High voltage is produced when this generator set is in operation. Make sure unit is completely shut down and free of any power source before attempting any repair or maintenance on the unit. Failure to comply can cause injury or death to personnel.</p>		
<p>DC voltages are present at generator set electrical components even with generator set shut down. Avoid shorting any positive with ground/negative. Failure to comply can cause injury to personnel and damage to equipment.</p>		
<p>7. Alarm module GENERATOR OVERLOAD amber indicator flashes. TQG disconnects from load.</p>	<p>1. Set ENGINE CONTROL switch to OFF/RESET.</p> <p>2. Set DEAD CRANK SWITCH to OFF.</p>	

Table 1. Operator Troubleshooting – Continued.

MALFUNCTION	TEST OR INSPECTION	CORRECTIVE ACTION
<p>7. Alarm module GENERATOR OVERLOAD amber indicator flashes. TQG disconnects from load. – Continued</p>	<p>3. Set Battery Disconnect Switch to OFF.</p> <p>4. Check load connected to TQG to see if there was a problem there that could cause TQG to overload.</p> <p>5. Determine if load is too large for generator set (Power requirement cannot be larger than TQG rating.)</p> <p>6. Determine if load has been increased.</p> <p>7. Set Battery Disconnect Switch to ON.</p> <p>8. Set DEAD CRANK SWITCH to NORMAL.</p> <p>9. Set ENGINE CONTROL switch to STOP COOL/DOWN.</p> <p>10. Press LAMP TEST on alarm module to reset overload fault detection circuit.</p> <p>11. Start and operate TQG (WP 0006 00-11).</p>	<p>Repair cause of overload or notify maintenance.</p> <p>Reduce load below output capacity of generator set.</p> <p>Reduce load as necessary.</p> <p>1. Monitor TQG for further problems.</p> <p>2. If there is no identifiable problem with the load and alarm recurs, notify maintenance.</p>
<p>8. Alarm module LOW FUEL LEVEL red indicator glows steady. TQG engine shuts down.</p>	<p>1. On EMCP, verify low fuel level on fuel gauge.</p> <p>2. Check that auxiliary fuel source is in use.</p> <p>3. On EMCP, verify AUX FUEL pump switch is set to ON.</p> <p>4. Verify that external (auxiliary) fuel source is present and that there is fuel in external fuel source container.</p>	<p>1. If required, service and fill fuel tank per WP 0016 00.</p> <p>If needed, connect auxiliary fuel hose to TQG per WP 0006 00.</p> <p>Set AUX FUEL pump switch to ON.</p> <p>If external fuel is present at source, notify maintenance to troubleshoot auxiliary fuel pump.</p>

CAUTION

The maximum power rating for the convenience receptacle is 15A. To prevent circuit breaker from opening, the total current drawn should be limited to 15A only. Failure to limit the load to less than 15A may trip the circuit breaker and damage the generator set or load.

<p>9. Convenience receptacle on PARALLELING RECEPTACLES panel has no power.</p>	<ol style="list-style-type: none"> 1. Check that load is no more than 15A. 2. Turn off equipment powered by convenience receptacles and remove all plugs from outlets. 3. Check GROUND FAULT CIRCUIT INTERRUPTER (GFCI) circuit breaker (WP 0013 00). 4. Under GROUND FAULT CIRCUIT INTERRUPTER nameplate press TEST pushbutton on GFCI circuit breaker. 5. Press RESET pushbutton on GFCI circuit breaker. 6. Check load is no more than 15A and for possible ground fault. 	<p>If load is greater than 15A, reduce load.</p> <p>If tripped, reset thermal overload on GROUND FAULT CIRCUIT INTERRUPTER circuit breaker (WP 0013 00).</p> <p>If TEST window is not red when TEST is pressed, notify maintenance.</p> <p>If TEST window is not clear when RESET is pressed, notify maintenance.</p> <p>If load is greater than 15A, reduce size of load. If no ground fault or overload exists, plug equipment back into convenience receptacle.</p>
<p>10. Winterization kit (issued to selected units only) is not operating. Red DIAGNOSTIC light is on.</p>	<ol style="list-style-type: none"> 1. On FUEL FIRED HEATER CONTROL panel, press CIRCUIT BREAKER and verify that switch is set to ON and indicator is lit. 2. Push press to test press-to-test HEATER indicator light. 3. Verify red DIAGNOSTIC light is on. 	<p>If switch is OFF, set to ON.</p> <p>If indicator does not light, notify maintenance.</p> <p>Set CIRCUIT BREAKER switch to OFF and notify maintenance.</p>

END OF TASK

CHAPTER 4
OPERATOR MAINTENANCE INSTRUCTIONS
FOR
100 kW TACTICAL QUIET GENERATOR SET

CHAPTER 4

OPERATOR MAINTENANCE INSTRUCTIONS FOR 100 kW TACTICAL QUIET GENERATOR SET

WORK PACKAGE INDEX

<u>Title</u>	<u>WP Sequence No.</u>
SERVICE UPON RECEIPT.....	0011 00
PREVENTIVE MAINTENANCE CHECKS AND SERVICES (PMCS), INCLUDING LUBRICATION INSTRUCTIONS	0012 00
CONTROL BOX ASSEMBLY MAINTENANCE	0013 00
ENGINE AIR CLEANER MAINTENANCE	0014 00
ENGINE COOLING SYSTEM MAINTENANCE.....	0015 00
ENGINE FUEL SYSTEM MAINTENANCE	0016 00
ENGINE LUBRICATION SYSTEM MAINTENANCE	0017 00
PREPARATION FOR STORAGE OR SHIPMENT	0018 00

**100 kW TACTICAL QUIET GENERATOR SET
SERVICE UPON RECEIPT**

0011 00

THIS WORK PACKAGE COVERS:

Preliminary Checks and Adjustment of Equipment

INITIAL SETUP:

Maintenance Level

Operator

Tools and Special Tools

None

Personnel Required

One

References

WP 0012 00
AFTO Form 22
DA Form 2028-2
DA Form 2404
DA Form 5988-E
DA PAM 738-750
DD Form 314
NAVMC 10524
NAVMC 10560
NAVMC 10772
SF Form 368

Materials/Parts

None

PRELIMINARY CHECKS AND ADJUSTMENT OF EQUIPMENT

1. (US Army, Air Force, and Marine Corps) Inspect equipment for possible damage incurred during shipment. If equipment has been damaged, report damage on SF Form 368, Product Quality Deficiency Report.
2. (US Army) Check equipment against packing slip to see if shipment is complete. Report all differences using procedure given in DA PAM 738-750.
3. US Army and Air Force operator perform Preventive Maintenance Checks and Services (PMCS) (WP 0012 00). Marine Corps use NAVMC 10560 to record all PMCS work.
4. US Army and Air Force notify maintenance to perform unit PMCS per TM 9-6115-729-24.
5. US Army and Air Force schedule next PMCS on DD Form 314, Preventive Maintenance Schedule and Record. Marine Corps use NAVMC 10524, Consolidated Engineer Equipment Operations Log and Service Record to indicate the next scheduled PMCS.
6. US Army report all deficiencies, including deficiencies that appear to involve unsatisfactory design, on DA Form 5988-E, automated form in the Unit Level Logistics System (ULLS), generated Equipment Maintenance and Inspection Worksheet. When no automation is available, use DA Form 2404 (Equipment Inspection and Maintenance Worksheet). Both forms serve the same purpose. Air Force and Marine Corps report all deficiencies on SF Form 368.

PRELIMINARY CHECKS AND ADJUSTMENT OF EQUIPMENT – Continued

7. If there is a recommended change to equipment technical publications, complete DA Form 2028-2 and forward it by e-mail to AMSEL-LC-LEO-PUBS-CHG@mail1.monmouth.army.mil, or online <http://edm.monmouth.army.mil/pubs/2028.html>. Alternately, you may mail or fax your letter, DA Form 2028 (Recommended changes to Publications and Blank Forms) or DA Form 2028-2 located in back of this manual direct to Commander, U.S. Army Communications-Electronics Life Cycle Management Command, ATTN: AMSEL-LC-LEO-E-ED, Fort Monmouth, New Jersey 07703-5006. The fax number is (732) 532-3421, DSN 992-3421.

For Air Force, use AFTO Form 22 in accordance with TO 00-5-1 and mail directly to Commander, WR-ALC/LEET, Robins AFB, GA, 31098. You may also e-mail your form to [http://wralc.tilta.afto@robins.af.mil](mailto:wralc.tilta.afto@robins.af.mil).

For Marine Corps, submit notice of discrepancies or suggested changes on a NAVMC 10772. The NAVMC may be submitted via the internet using website <http://pubs.ala.usmc.mil/front.htm>, scrolling down to the NAVMC 10772 Tracking Program and following instructions provided. It may also be submitted by electronic mail to <mailto:mbmatcommarlogbases@logcom.usmc.mil> or by mailing paper copy NAVMC 10772 in an envelope addressed to Commander, Marine Corps Systems Command, Attn: Assistant Commander Acquisitions and Logistics (LOG/TP), 814 Radford Blvd, Suite 20343, Albany, Georgia 31704-0343.

END OF TASK

**100 kW TACTICAL QUIET GENERATOR SET
PREVENTIVE MAINTENANCE CHECKS AND SERVICES (PMCS), INCLUDING LUBRICATION
INSTRUCTIONS**

0012 00

THIS WORK PACKAGE COVERS:

- Introduction
 - Fluid Leakage
 - Inspection
 - PMCS Column Descriptions
 - PMCS Table 1
-

INITIAL SETUP:

Maintenance Level

Operator

References

- WP 0005 00
- WP 0010 00
- WP 0011 00
- WP 0014 00
- WP 0015 00
- WP 0016 00
- WP 0017 00
- DA Form 5988-E
- DA PAM 738-750

Tools and Special Tools

None

Materials/Parts

- Cleaning compound (item 2, WP 0022 00)
- Wiping rags (item 18, WP 0022 00)

Personnel Required

One

INTRODUCTION

PMCS are performed to keep the 100 kW TQG in operating condition. Inspect the TQG within specified intervals so defects are found and corrected or problems are reported before any serious damage or failure occurs. Do the PMCS per Table 1. Pay attention to WARNINGS and CAUTIONS. A WARNING means someone could be hurt. A CAUTION means equipment could be damaged.

NOTE

Designated intervals are performed under usual operating conditions. PMCS intervals must be performed more frequently when operating under unusual conditions.

BEFORE PMCS is done before you start and operate the 100 kW TQG.

DURING PMCS is done while the equipment and/or its component systems are in operation.

AFTER PMCS is done immediately after operating and shutting down the 100 kW TQG.

**100 kW TACTICAL QUIET GENERATOR SET
PREVENTIVE MAINTENANCE CHECKS AND SERVICES (PMCS), INCLUDING LUBRICATION
INSTRUCTIONS – Continued**

INTRODUCTION – Continued

1. If you are operating the 100 kW TQG for the first time, you must do your BEFORE PMCS.
2. Always perform preventive maintenance in the same order so it gets to be a habit. Once you have had some practice, you will spot anything wrong in a hurry.
3. Wiping rags are needed to remove dirt or grease.
4. If you find a fault or shortcoming when performing the PMCS, record it on your DA Form 2404, or automated DA Form 5988-E (Army) if ULLS is available. Repair it if you can or notify maintenance.
5. If something appears to be a fault and you cannot repair it, record it on your DA Form 2404 or automated DA Form 5988-E (Army), MC10560 (Marine Corps). If you find something seriously wrong, report it to maintenance as soon as possible.
6. Item numbers in column 1 of PMCS Table 1 indicate the PMCS sequence. Use these item numbers for the item number column on DA Form 2404 or automated DA Form 5988-E for Army.
7. Information in column 5 of PMCS Table 1 lists conditions that make the 100 kW TQG not fully mission capable. Write up items not repaired on DA Form 2404 or automated DA Form 5988-E for maintenance. For further information on how to use these forms, see DA PAM 738-750.

FLUID LEAKAGE

Wetness around seals, gaskets, fittings, or connections indicates leakage. A stain also denotes leakage. If a fitting or connector is loose, tighten it if you can hand tighten. If not, notify maintenance. If a fitting or connector is broken or defective, report it to maintenance.

Leak Definitions for PMCS**CAUTION**

Operation is allowable with class I and II leakage. However, any wetness or leakage of fuel is classified as a class III leak and the TQG must be shut down immediately and the problem corrected. WHEN IN DOUBT, NOTIFY YOUR SUPERVISOR. When operating with class I or II leaks, check fluid levels more frequently. Class III leaks must be reported immediately to your supervisor or to maintenance. Failure to do this could result in damage to the 100 kW TQG and/or components.

1. Class I – Leakage indicated by wetness or discoloration, but not great enough to form drops.
2. Class II – Leakage great enough to form drops, but not enough to cause drops to drip from item being checked/inspected.
3. Class III – Leakage great enough to form drops that fall from the item being checked/inspected.

INSPECTION

Look for signs of a problem or trouble. You can feel, smell, hear, or see many problems. Be alert when in or around the 100 kW TQG.

Inspect the 100 kW TQG to see if items are in proper condition. Are they correctly assembled, stowed, and secured; excessively worn, leaking, corroded, or properly lubricated? Correct any problems found or notify maintenance.

**100 kW TACTICAL QUIET GENERATOR SET
PREVENTIVE MAINTENANCE CHECKS AND SERVICES (PMCS), INCLUDING LUBRICATION
INSTRUCTIONS – Continued**

0012 00

INSPECTION – Continued

There are some common items to check all over the TQG. These include the following:

WARNING



Cleaning compound is toxic. Avoid prolonged breathing of vapors. Use only in a well-ventilated area. Failure to comply can cause serious injury to personnel.

1. Dirt, grease, oil, and debris: They only get in the way and may cover up a serious problem. Keep the equipment clean. Clean as you work and as needed. Use cleaning compound to clean metal surfaces and rubber or plastic material.
2. Bolts, clamps, nuts, and screws: Continuously check for looseness. Look for chipped paint, bare metal, rust, or corrosion around bolts and screw heads and nuts. Tighten them when you find them loose. If tools are not available, notify maintenance.
3. Welds: Many items on the TQG skid mount are welded. To check these welds, look for chipped paint, rust, corrosion, or gaps. If broken weld(s) exist, notify maintenance on DA Form 2404 or automated DA Form 5988-E (Army).
4. Electrical wires, connectors, and harnesses: Tighten loose cannon plugs. Look for cracked or broken insulation, bare wires, loose cannon plugs, and broken connectors. When these conditions exist, notify maintenance.
5. Hoses and fluid lines: Check hoses and fluid lines for wear, damage, and leaks. Ensure clamps and fittings are tight.
6. Hinges: Check hinges for security and operation.
7. Data plates: Check data, caution and warning plates for security and legibility.

PMCS COLUMN DESCRIPTIONS (TABLE 1) (ARMY)

ITEM NO. – This column lists order in which PMCS should be performed; also used as a source of item numbers for the TM number column on DA Form 2404 or automated DA Form 5988-E (Army) when recording results of PMCS.

INTERVAL – This column indicates when each check is to be performed.

LOCATION/ITEM TO CHECK/SERVICE – This column lists location and item to be checked or serviced.

PROCEDURE – This column provides brief description of procedure as well as any information required to accomplish each check or service.

NOT FULLY MISSION CAPABLE IF – This column lists condition that would cause 100 kW TQG to be less than fully ready to perform its assigned mission.

**100 kW TACTICAL QUIET GENERATOR SET
PREVENTIVE MAINTENANCE CHECKS AND SERVICES (PMCS), INCLUDING LUBRICATION
INSTRUCTIONS – Continued**

Table 1. Preventive Maintenance Checks and Services.

ITEM NO.	INTERVAL	LOCATION/ ITEM TO CHECK/SERVICE	PROCEDURE	NOT FULLY MISSION CAPABLE IF:
1	Before	GENERATOR SET NATO Slave Connector	<p style="text-align: center;"><u>WARNING</u></p> <p>Slave receptacle (NATO connector) is electrically live at all times and is unfused. The Battery Disconnect Switch does not remove power from the slave receptacle. NATO slave receptacle has 24 VDC even when disconnect switch is set to OFF. This circuit is only dead when the batteries are fully disconnected. Disconnect the batteries before performing maintenance on the slave receptacle. Failure to comply can cause injury or death to personnel.</p> <p>Check for cracked or broken NATO slave connector or other damage.</p>	NATO slave connector is cracked or broken.
2	Before	Overall Exterior	<p>Check external doors, panels, hinges, and latches for damaged, loose or corroded items.</p> <p style="text-align: center;"><u>CAUTION</u></p> <p>Operating the generator set with restricted airflow for cooling can cause the generator set to overheat. Keep all access door inlet panels clear to ensure maximum airflow for engine and generator cooling. Failure to comply can result in poor engine performance and possible overheating and automatic shutdown.</p> <p>Inspect air intake and exhaust grills for debris.</p>	Cannot shut doors.
3	Before	Identification Plates	<p>Check to ensure identification plates on generator set are secure.</p>	Any restriction of air flow or cannot clear debris.

**100 kW TACTICAL QUIET GENERATOR SET
PREVENTIVE MAINTENANCE CHECKS AND SERVICES (PMCS), INCLUDING LUBRICATION
INSTRUCTIONS – Continued**

Table 1. Preventive Maintenance Checks and Services – Continued.

ITEM NO.	INTERVAL	LOCATION/ ITEM TO CHECK/SERVICE	PROCEDURE	NOT FULLY MISSION CAPABLE IF:
4	Before	Skid Base	Inspect skid base for cracks or corrosion, missing or damaged lift rings, or other damage.	Skid base is cracked or shows signs of structural damage or lifting rings are missing or damaged.
5	Before	Acoustical Materials	Ensure acoustical materials are securely in place, free of damage or not missing.	
6	Before	ENGINE COMPARTMENT Engine Assembly	<p style="text-align: center;"><u>WARNING</u></p> <p>DC voltages are present at generator set electrical components even with generator set shut down. Avoid shorting any positive with ground/negative. Failure to comply can cause injury to personnel and damage to equipment.</p> <p>Check for loose, damaged, or missing hardware.</p>	Hardware is loose, damaged, or missing.
7	Before	Fuel System	<p style="text-align: center;"><u>WARNING</u></p> <p>Fuels used in the generator set are flammable. Do not smoke or use open flames when performing maintenance. Failure to comply can result in flames and possible explosion and can cause injury or death to personnel and damage to the generator set.</p> <p>Inspect fuel system for leaks, damaged, loose or missing parts.</p> <p style="color: red;">If using auxiliary fuel source, check for leaks, damaged, loose or missing parts.</p>	Any fuel leaks, damaged, loose, or missing parts.
8	Before	Fuel Filter/Water Separator	Inspect fuel filter/water separator for leaks, proper mounting, cracks, damage, or missing parts.	Any fuel leaks, cracks, or missing parts.

**100 kW TACTICAL QUIET GENERATOR SET
PREVENTIVE MAINTENANCE CHECKS AND SERVICES (PMCS), INCLUDING LUBRICATION
INSTRUCTIONS – Continued**

0012 00

Table 1. Preventive Maintenance Checks and Services – Continued.

ITEM NO.	INTERVAL	LOCATION/ ITEM TO CHECK/SERVICE	PROCEDURE	NOT FULLY MISSION CAPABLE IF:
9	Before	Fuel Filter/Water Separator – Continued Lubrication System	Drain water from fuel filter/water separator (WP 0016 00). Inspect lubrication system for leaks, damaged, loose, or missing parts. Check engine oil level (WP 0017 00). Check engine oil for contamination.	Fuel filter/water separator contains sediment and/or water or cannot be drained. Class III leaks. Damaged, loose, or missing parts. Oil level is below cold (low) oil level mark on dipstick. Engine oil is milky, discolored, or shows signs of contamination.
10	Before	COOLING SYSTEM Radiator	<u>WARNING</u> Cooling system operates at high temperature and pressure. Contact with high pressure steam and/or liquids can result in burns and scalding. Shut down generator set, and allow system to cool before performing checks, services and maintenance. Failure to comply can cause injury or death to personnel. Check radiator for leaks, damage or missing parts.	Class III leaks. Coolant fill cap missing or damaged.
11	Before	Fan Guards	Check fan guards and shroud for dirt and debris blocking air flow.	Dirt or debris block air flow.
12	Before	Hoses	Check hoses for leaks or cracks.	Class III leaks.
13	Before	Cooling Fan	Check fan for damage or looseness.	Cooling fan is damaged or loose.
14	Before	Fan Belts	Inspect belts to ensure that they are not missing. Inspect for cracks, fraying, and looseness.	Broken, missing or loose belt(s).

**100 kW TACTICAL QUIET GENERATOR SET
PREVENTIVE MAINTENANCE CHECKS AND SERVICES (PMCS), INCLUDING LUBRICATION
INSTRUCTIONS – Continued**

Table 1. Preventive Maintenance Checks and Services – Continued.

ITEM NO.	INTERVAL	LOCATION/ ITEM TO CHECK/SERVICE	PROCEDURE	NOT FULLY MISSION CAPABLE IF:
15	Before	Overflow Bottle	<p>Check overflow bottle for leaks, cracks, or missing parts.</p> <p>Check coolant level above COLD line in overflow bottle (WP 0015 00).</p>	<p>Class III leaks or overflow bottle missing.</p> <p>Coolant level is below COLD line.</p>
16	Before	Exhaust System	<p>Check muffler and exhaust system for corrosion, damaged, or missing parts.</p> <p>Check exhaust system for restrictions and proper venting to atmosphere.</p>	<p>Muffler or exhaust system have missing parts.</p> <p>Restricted exhaust</p>
17	Before	Air Cleaner Assembly	<p>Inspect air cleaner assembly and piping for loose or damaged connections.</p> <p>Check restriction indicator for clogged element (WP 0014 00).</p>	<p>Clogged element is indicated (red), piping and connections loose, restriction indicator broken or missing.</p>
18	Before	Battery Cables	<p style="text-align: center;"><u>WARNING</u></p> <p>DC voltages are present at generator set electrical components even with generator set shut down. Avoid shorting any positive with ground/negative. Failure to comply can cause injury to personnel and damage to equipment.</p> <p>Inspect cables and connectors for corrosion, loose, damaged or missing parts.</p>	<p>Cables are loose, damaged or missing.</p> <p>Batteries fail to start generator.</p>
19	Before	Output Load Terminal Board	<p>Check for loose or damaged wiring or load cables inside generator set.</p> <p>Check output terminals for damaged, loose or missing hardware.</p>	<p>Loose or damaged wiring or cables.</p> <p>Damaged, loose or missing hardware.</p>
20	Before	Reconnection Board	<p>Verify position of Reconnection Board and check to see if it is in the correct position for voltage outputs required by load.</p> <p>Notify maintenance if repositioning is required.</p>	<p>Reconnection Board is set for incorrect voltage output.</p>

**100 kW TACTICAL QUIET GENERATOR SET
PREVENTIVE MAINTENANCE CHECKS AND SERVICES (PMCS), INCLUDING LUBRICATION
INSTRUCTIONS – Continued**

0012 00

Table 1. Preventive Maintenance Checks and Services – Continued.

ITEM NO.	INTERVAL	LOCATION/ ITEM TO CHECK/SERVICE	PROCEDURE	NOT FULLY MISSION CAPABLE IF:
		CONTROL PANEL ASSEMBLY	<p style="text-align: center;"><u>WARNING</u></p> <p>Metal jewelry can conduct electricity and become entangled in generator set components. Remove all metal jewelry when working on generator set. Failure to comply can cause injury or death to personnel.</p> <p>DC voltages are present at generator set electrical components even with generator set shut down. Avoid shorting any positive with ground/negative. Failure to comply can cause injury to personnel and damage to equipment.</p> <p>Set DEAD CRANK SWITCH to NORMAL (WP 0005 00).</p> <p>Set Battery Disconnect Switch to ON (WP 0005 00).</p> <p>Set ENGINE CONTROL switch to COOL DOWN/STOP (WP 0005 00).</p>	
21	Before	Indicators and Controls	Check all indicators and controls for damaged or missing parts.	Indicators or controls damaged or missing.
22	Before	Control Panel Wiring Harness	Check for loose or damaged wiring or connectors.	Loose or damaged wiring or connectors.
23	Before	Generator Set Control	Touch LAMP TEST on keypad and check that all eight indicator lights on GSC and upper and lower display segments light.	GSC indicator lights and display segments do not light.
24	Before	Alarm Module	Press LAMP TEST and check that alarm indicators light and alarm sounds.	Alarm Module lights do not light and alarm does not sound.
25	Before	Parallel Cable	If required for generator set operation, inspect parallel cable for damage.	Parallel cable missing or damaged.

**100 kW TACTICAL QUIET GENERATOR SET
PREVENTIVE MAINTENANCE CHECKS AND SERVICES (PMCS), INCLUDING LUBRICATION
INSTRUCTIONS – Continued**

0012 00

Table 1. Preventive Maintenance Checks and Services – Continued.

ITEM NO.	INTERVAL	LOCATION/ ITEM TO CHECK/SERVICE	PROCEDURE	NOT FULLY MISSION CAPABLE IF:
26	Before	Ground Rod Cable and Connection	<p style="text-align: center;"><u>WARNING</u></p> <p>High voltage is produced when the generator set is in operation. Never attempt to start the generator set unless it is properly grounded. Failure to comply can cause injury or death to personnel.</p> <p>Inspect ground rod and cable for loose connections, breaks, damage and corrosion.</p>	Any missing or damaged parts.
27	Before	PU-807A TRAILER INSTALLATION Identification plates	If generator set is trailer-mounted (PU-807A), check to ensure identification plates on trailer are secure.	
28	Before	Fire Extinguisher	<p>Verify that two fire extinguishers are mounted to trailer brackets and are fully charged.</p> <p>Check that fire extinguisher needle (if applicable) is in green zone.</p> <p>Check fire extinguisher seal. If seal is broken or missing, replace fire extinguisher.</p> <p>Visually inspect bracket for obvious damage.</p>	Fire extinguishers are not present or not certified. Needle is not in green zone.
29	Before	Ground Rod Cable and Connection	<p style="text-align: center;"><u>WARNING</u></p> <p>High voltage is produced when this generator set is in operation. Make sure unit is completely shut down and free of any power source before attempting any repair or maintenance on the unit. Failure to comply can cause injury or death to personnel.</p> <p>Inspect ground rod, grounding cable to trailer terminal, and grounding cable to generator set, for loose connections, breaks, damage and corrosion.</p>	Any missing or damaged parts. Connections are loose or corroded.

**100 kW TACTICAL QUIET GENERATOR SET
PREVENTIVE MAINTENANCE CHECKS AND SERVICES (PMCS), INCLUDING LUBRICATION
INSTRUCTIONS – Continued**

Table 1. Preventive Maintenance Checks and Services – Continued.

ITEM NO.	INTERVAL	LOCATION/ ITEM TO CHECK/SERVICE	PROCEDURE	NOT FULLY MISSION CAPABLE IF:
30	Before	Accessory Box	Inspect accessory box clamping hatch hasp and rivets for rust, corrosion and wear. Check accessory box contents to ensure that all required items are present and are serviceable.	Ground rod and components are missing or unserviceable.
31	Before	WINTERIZATION KIT Fuel lines	<p style="text-align: center;"><u>WARNING</u></p> <p>Fuels used in the generator set are flammable. Do not smoke or use open flames when performing maintenance. Failure to comply can result in flames and possible explosion and can cause injury or death to personnel and damage to the generator set.</p> Open battery access doors and inspect fuel lines to fuel-fired heater for leaks, damaged, loose or missing parts.	Any fuel leaks, damaged, loose, or missing parts.
32	Before	Coolant hoses	Check hoses for leaks or cracks.	Class III leaks.
33	Before	Coolant shutoff valves ENGINE COMPARTMENT	Verify that coolant shutoff valves on engine are secure. <p style="text-align: center;"><u>WARNING</u></p> <p>Operating the generator set exposes personnel to a high noise level. Hearing protection must be worn when operating or working near the generator set when the generator set is running. Failure to comply can cause hearing damage to personnel.</p>	Shutoff valves are not secure.

**100 kW TACTICAL QUIET GENERATOR SET
PREVENTIVE MAINTENANCE CHECKS AND SERVICES (PMCS), INCLUDING LUBRICATION
INSTRUCTIONS – Continued**

0012 00

Table 1. Preventive Maintenance Checks and Services – Continued.

ITEM NO.	INTERVAL	LOCATION/ ITEM TO CHECK/SERVICE	PROCEDURE	NOT FULLY MISSION CAPABLE IF:
		ENGINE COMPARTMENT – Continued	<p style="text-align: center;"><u>WARNING</u></p> <p>Top housing panels can get very hot. When performing DURING PMCS, wear gloves and additional protective clothing as required. Failure to comply can result in severe burns to personnel.</p> <p style="text-align: center;"><u>WARNING</u></p> <p>DO NOT wear loose clothing when performing checks, services and maintenance. Failure to comply can cause injury or death to personnel.</p> <p style="text-align: center;"><u>WARNING</u></p> <p>When running, generator set engine has hot metal surfaces that will burn flesh on contact. When performing DURING PMCS, wear gloves and additional protective clothing as required. Failure to comply can cause injury or death to personnel.</p> <p style="text-align: center;"><u>WARNING</u></p> <p>When running, winterization heater has hot metal surfaces that will burn flesh on contact. Shut down generator set and allow heater to cool before performing maintenance. Wear gloves and additional protective clothing as required. Failure to comply can cause injury or death to personnel.</p>	

**100 kW TACTICAL QUIET GENERATOR SET
PREVENTIVE MAINTENANCE CHECKS AND SERVICES (PMCS), INCLUDING LUBRICATION
INSTRUCTIONS – Continued**

0012 00

Table 1. Preventive Maintenance Checks and Services – Continued.

ITEM NO.	INTERVAL	LOCATION/ ITEM TO CHECK/SERVICE	PROCEDURE	NOT FULLY MISSION CAPABLE IF:
34	During	ENGINE COMPARTMENT – Continued ENGINE COMPARTMENT – Continued Fuel System	<p style="text-align: center;"><u>WARNING</u></p> <p>Fuels used in the generator set are flammable. Do not smoke or use open flames when performing maintenance. Failure to comply can result in flames and possible explosion and can cause injury or death to personnel and damage to the generator set.</p> <p style="text-align: center;">NOTE</p> <p>If the TQG is operating continuously, do the DURING checks every four hours.</p> <p>Inspect fuel system for leaks, damaged, loose or missing parts.</p>	Any fuel leaks, damaged, loose or missing parts.
35	During	Lubrication System	<p>Inspect lubrication system for leaks, damaged, loose or missing parts.</p> <p>Check engine oil level (WP 0017 00).</p>	Class III leaks. Damaged, loose or missing parts. Oil level is below hot add oil level mark on dipstick.
36	During	COOLING SYSTEM Cooling Fan	<p style="text-align: center;"><u>WARNING</u></p> <p>Cooling system operates at high temperature and pressure. When performing DURING PMCS, wear gloves and additional protective clothing and goggles as required. Contact with high pressure steam and/or liquids can result in burns and scalding.</p> <p>Check for unusual noise being emitted from fan area.</p>	Cooling fan is damaged or loose.
37	During	Overflow Bottle	Check coolant level between COLD and HOT lines in overflow bottle (WP 0015 00).	Coolant level is below COLD line.

**100 kW TACTICAL QUIET GENERATOR SET
PREVENTIVE MAINTENANCE CHECKS AND SERVICES (PMCS), INCLUDING LUBRICATION
INSTRUCTIONS – Continued**

Table 1. Preventive Maintenance Checks and Services – Continued.

ITEM NO.	INTERVAL	LOCATION/ ITEM TO CHECK/SERVICE	PROCEDURE	NOT FULLY MISSION CAPABLE IF:
38	During	Exhaust System	<p style="text-align: center;"><u>WARNING</u></p> <p>Hot exhaust gases can ignite flammable materials. Allow room for safe discharge of hot gases and sparks. Failure to comply can cause injury or death to personnel.</p> <p style="text-align: center;"><u>WARNING</u></p> <p>Exhaust discharge contains deadly gases including carbon monoxide. Do not operate generator set in an enclosed area unless exhaust discharge is properly vented outside. Failure to comply can cause injury or death to personnel.</p> <p style="text-align: center;"><u>WARNING</u></p> <p>Exhaust system can get very hot. When performing DURING PMCS, wear gloves and additional protective clothing as required. Failure to comply can cause severe burns and injury to personnel.</p> <p>Visually inspect muffler and exhaust system for leaks or missing parts.</p>	Muffler or exhaust system missing parts.
39	During	Electronic Modular Control Panel (EMCP)	Ensure all indicators are operating properly.	Fuel gage, DC ammeter, GSC display module, or Digital Voltage Regulator (DVR) inoperative.
40	During	Ground Rod Cable and Connection	Visually inspect ground rod and cable for breaks and damage.	Cable is missing or damaged.

**100 kW TACTICAL QUIET GENERATOR SET
PREVENTIVE MAINTENANCE CHECKS AND SERVICES (PMCS), INCLUDING LUBRICATION
INSTRUCTIONS – Continued**

Table 1. Preventive Maintenance Checks and Services – Continued.

ITEM NO.	INTERVAL	LOCATION/ ITEM TO CHECK/SERVICE	PROCEDURE	NOT FULLY MISSION CAPABLE IF:
41	During	Overall Exterior	<p>Check external doors, panels, hinges, and latches for damaged, loose or corroded items.</p> <p style="text-align: center;"><u>CAUTION</u></p> <p>Operating the generator set with restricted airflow for cooling can cause the generator set to overheat. Keep all access door inlet panels clear to ensure maximum airflow for engine and generator cooling. Failure to comply can result in poor engine performance and possible overheating and automatic shutdown.</p> <p>Inspect air intake and exhaust grills for debris.</p>	<p>Cannot shut doors.</p> <p>Any restriction of air flow or cannot clear debris.</p>
42	After	ENGINE COMPARTMENT Engine Assembly	<p>Check for loose damaged or missing hardware.</p>	<p>Hardware loose, damaged, or missing.</p>
43	After	Fuel System	<p style="text-align: center;"><u>WARNING</u></p> <p>Fuels used in the generator set are flammable. Do not smoke or use open flames when performing maintenance. Failure to comply can result in flames and possible explosion and can cause injury or death to personnel and damage to the generator set.</p> <p>Inspect fuel system for leaks, damaged, loose or missing parts.</p>	<p>Any fuel leaks, damaged, loose or missing parts.</p>
44	After	Fuel Filter/Water Separator	<p>Inspect fuel filter/water separator for leaks, proper mounting, cracks, damage, or missing parts.</p> <p>Drain water from fuel filter/water separator (WP 0016 00).</p>	<p>Any fuel leaks, cracks, or missing parts.</p> <p>Fuel filter/water separator contains sediment and/or water or cannot be drained.</p>

**100 kW TACTICAL QUIET GENERATOR SET
PREVENTIVE MAINTENANCE CHECKS AND SERVICES (PMCS), INCLUDING LUBRICATION
INSTRUCTIONS – Continued**

Table 1. Preventive Maintenance Checks and Services – Continued.

ITEM NO.	INTERVAL	LOCATION/ ITEM TO CHECK/SERVICE	PROCEDURE	NOT FULLY MISSION CAPABLE IF:
45	After	Lubrication System	Inspect lubrication system for leaks, damaged, loose or missing parts. Check engine oil level (WP 0017 00).	Class III leaks. Damaged, loose or missing parts. Oil level is below low oil level mark on dipstick.
46	After	COOLING SYSTEM Radiator	<u>WARNING</u> Cooling system operates at high temperature and pressure. Contact with high pressure steam and/or liquids can result in burns and scalding. Shut down generator set, and allow system to cool before performing checks, services, and maintenance. Failure to comply can cause injury or death to personnel. Check radiator for leaks, damage or missing parts.	Class III leaks. Coolant refill cap missing.
47	After	Hoses	Check hoses for leaks or cracks or loose clamps.	Class III leaks.
48	After	Cooling Fan	Check fan for damage or looseness.	Cooling fan is damaged or loose.
49	After	Fan Belts	Inspect belts to ensure that they are not missing. Inspect for cracks, fraying, and looseness.	Broken, missing or loose belt(s).
50	After	Overflow Bottle	Check overflow bottle for cracks, leaks or missing parts. Check coolant level (WP 0015 00).	Class III leaks. Coolant level is below COLD line.
51	After	Electronic Modular Control Panel (EMCP) Indicators and Controls	Check all indicators and controls for damaged or missing parts.	Indicators or controls damaged or missing.

**100 kW TACTICAL QUIET GENERATOR SET
PREVENTIVE MAINTENANCE CHECKS AND SERVICES (PMCS), INCLUDING LUBRICATION
INSTRUCTIONS – Continued**

0012 00

Table 1. Preventive Maintenance Checks and Services – Continued.

ITEM NO.	INTERVAL	LOCATION/ ITEM TO CHECK/SERVICE	PROCEDURE	NOT FULLY MISSION CAPABLE IF:
52	After	Overall Exterior	<p>Check external doors, panels, hinges, and latches for damaged, loose or corroded items.</p> <p style="text-align: center;"><u>CAUTION</u></p> <p>Operating the generator set with restricted airflow for cooling can cause the generator set to overheat. Keep all access door inlet panels clear to ensure maximum airflow for engine and generator cooling. Failure to comply can result in poor engine performance and possible overheating and automatic shutdown.</p> <p>Inspect air intake and exhaust grills for debris.</p>	<p>Cannot shut doors.</p> <p>Any restriction of air flow or cannot clear debris.</p>
53	After	Accessory Box	<p>Inspect accessory box clamping hatch hasp for operation.</p> <p>Check accessory box contents to ensure that all required items are present and are serviceable.</p>	<p>Ground rod and components are missing or unserviceable.</p>

END OF TASK

**100 kW TACTICAL QUIET GENERATOR SET
CONTROL BOX ASSEMBLY MAINTENANCE**

0013 00

THIS WORK PACKAGE COVERS:

Repair

INITIAL SETUP:**Maintenance Level**

Operator

References

None

Tools and Special Tools

None

Materials/Parts

Incandescent lamp

Personnel Required

One



Metal jewelry can conduct electricity and become entangled in generator set components. Remove all metal jewelry when working on generator set. Failure to comply can cause injury or death to personnel.

High voltage is produced when this generator set is in operation. Make sure unit is completely shut down and free of any power source before attempting any repair or maintenance on the unit. Failure to comply can cause injury or death to personnel.

DC voltages are present at generator set electrical components even with generator set shut down. Avoid shorting any positive with ground/negative. Failure to comply can cause injury to personnel and damage to equipment.

REPAIR**Replace Control Panel Lights On Electronic Modular Control Panel (EMCP)**

1. On EMCP, set ENGINE CONTROL switch to OFF/RESET.
2. Set DEAD CRANK SWITCH to OFF.
3. Set Battery Disconnect switch to OFF.
4. Open control panel access cover and turn three captive retainers (1) and lower EMCP front panel (2).
5. Inspect wiring to lamps.
6. If wiring is broken, notify maintenance.
7. Close EMCP front panel (2) and secure with three captive retainers (1).

**100 kW TACTICAL QUIET GENERATOR SET
CONTROL BOX ASSEMBLY MAINTENANCE – Continued**

0013 00

REPAIR – Continued

Replace Control Panel Lights On Electronic Modular Control Panel (EMCP) – Continued

8. If wiring is not broken, remove lamp lens (3) and light bulb (4) of defective panel light (5) or indicator light (6).
9. Replace burned out light bulb with new light bulb (4) and install lamp lens (3).

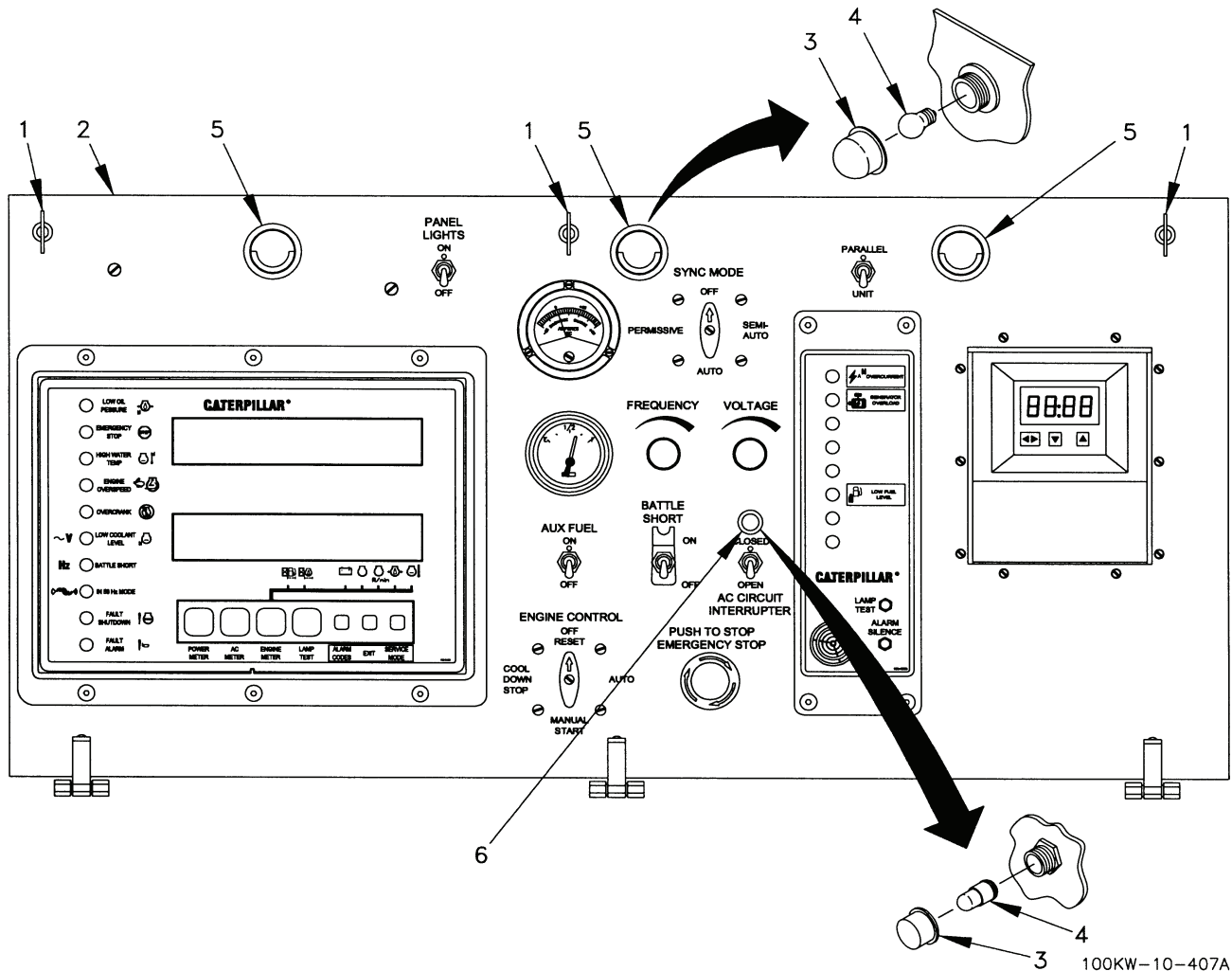

END OF TASK

REPAIR - Continued

Reset GROUND FAULT CIRCUIT INTERRUPTER Circuit Breaker

If the GROUND FAULT CIRCUIT INTERRUPTER (GFCI) circuit breaker is not operating correctly, perform the following steps to reset it.

1. On EMCP, set ENGINE CONTROL switch to OFF/RESET.
2. Set DEAD CRANK SWITCH to OFF.
3. Set Battery Disconnect switch to OFF.
4. Open control panel access panel and turn three captive retainers (1) and lower EMCP front panel (2).
5. Visually inspect wiring to body of GFCI (7).
6. If wiring is not broken, reset GFCI (7) by pressing PUSH TO RESET THERMAL BREAKER (8) located behind the control panel on side of GFCI and then pushing RESET button (7) on front panel.
7. If wiring to GFCI appears to be broken, notify maintenance.
8. Close EMCP front panel (2) and secure with three captive retainers (1).

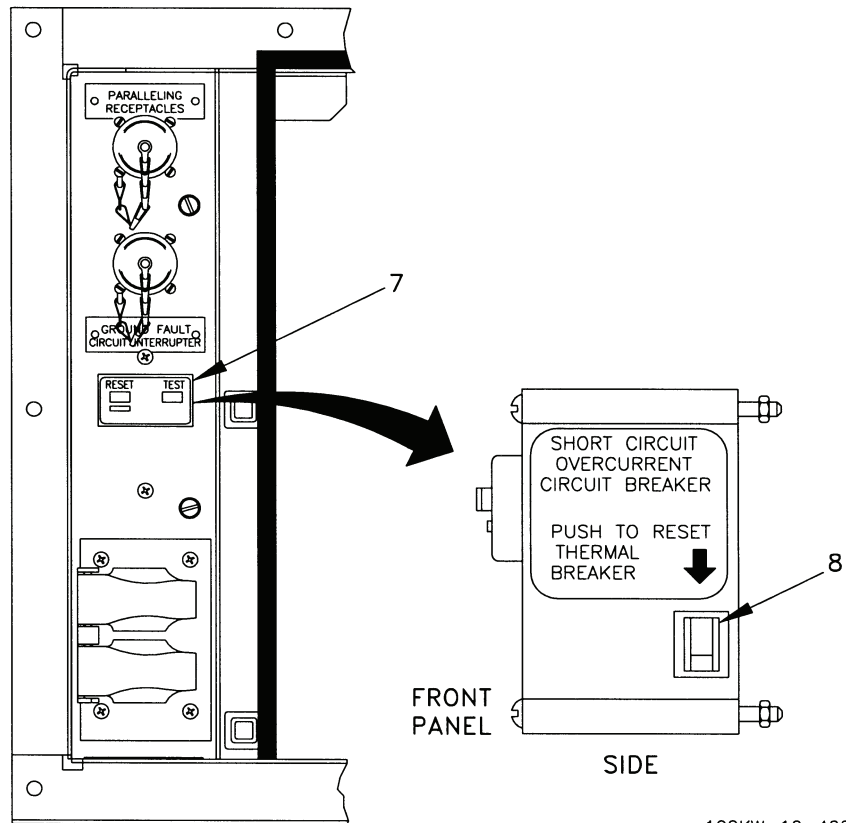

100KW-10-408A

END OF TASK

**100 kW TACTICAL QUIET GENERATOR SET
ENGINE AIR CLEANER MAINTENANCE**

0014 00

THIS WORK PACKAGE COVERS:

Inspection
Service

INITIAL SETUP:

Maintenance Level
Operator

References
None

Tools and Special Tools
None

Materials/Parts
Wiping rags (item 18, WP 0022 00)
Air cleaner filters

Personnel Required
One

INSPECTION

1. On EMCP, set ENGINE CONTROL switch to OFF/RESET.
2. Open left rear housing door to access air cleaner.
3. Open right rear engine compartment access door.
4. Inspect air cleaner housing (1) and end cap (2) for dents, corrosion, damaged seal, missing hardware, and other damage.
5. Inspect restriction indicator (3) for indication of clogged air cleaner elements. If restriction indicator red cylinder is in the clear body of the indicator, SERVICE air cleaner.
6. Close housing doors.

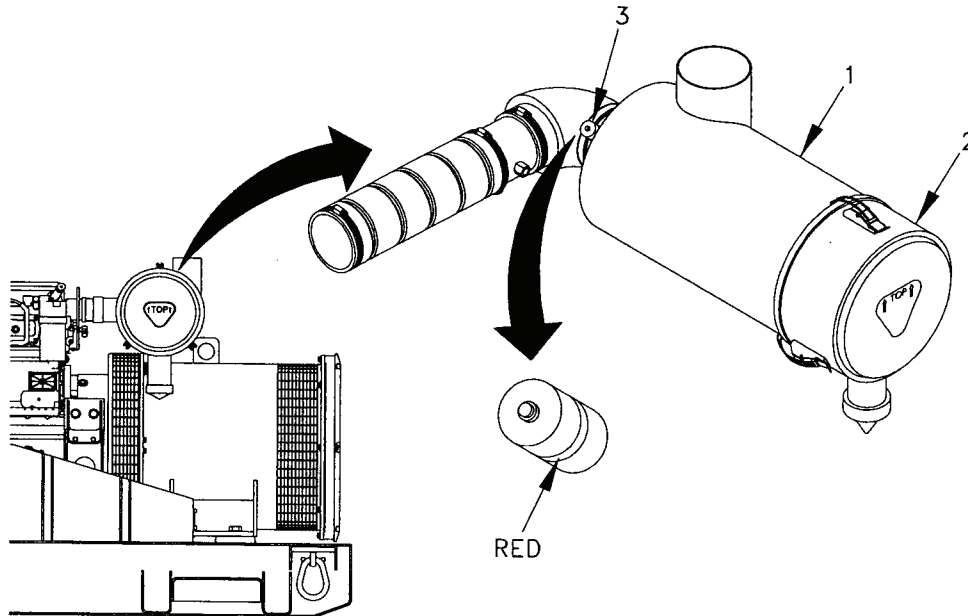

100KW-10-401C

END OF TASK

**100 kW TACTICAL QUIET GENERATOR SET
ENGINE AIR CLEANER MAINTENANCE – Continued**

0014 00

SERVICE

1. On EMCP, set ENGINE CONTROL switch to OFF/RESET.
2. Set DEAD CRANK SWITCH to OFF.
3. Set Battery Disconnect Switch to OFF.
4. Open access doors at left rear of generator set housing to access air cleaner.
5. Unlatch three latches (4) and remove air cleaner end cap (2) from air cleaner housing (1).
6. Remove outer air cleaner element (5).
7. Remove inner air cleaner element (6).
8. Squeeze rubber dust cup (7) at bottom of end cap (2) extension several times to expel dust and debris.
9. Inspect inside of air cleaner housing (1) for debris.
10. Wipe housing interior with clean lint-free cloth.

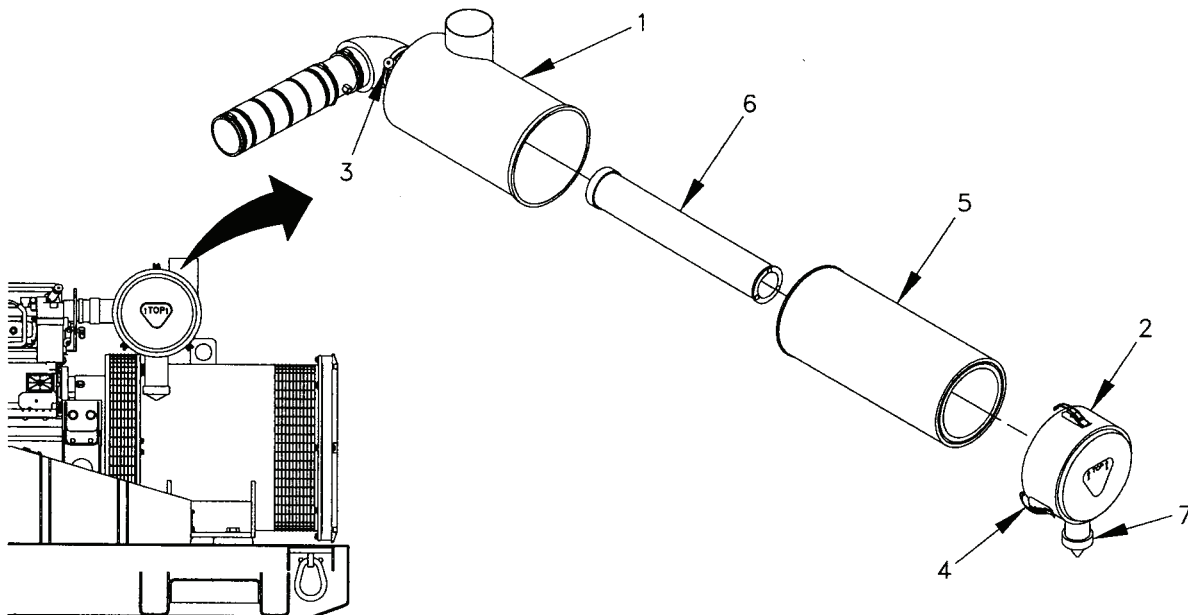

100KW-10-409A

WARNING

Eye protection is required when working with compressed air. Compressed air can propel particles at high velocity and injure eyes. Do not exceed 15 psi pressure when using compressed air. Failure to comply could cause serious injury to personnel.

11. Clean inner air cleaner element (6) and outer air cleaner element (5) with compressed air or by tapping elements to remove loose dirt.
12. Install inner air cleaner element (6), outer air cleaner element (5), and end cap (2) and secure three latches (4).
13. Reset restriction indicator (3) by pressing button on top of indicator. Red plunger will retract into body of indicator.
14. Close housing doors.
15. After operating TQG inspect restriction indicator (3) when performing DURING PMCS. If red plunger returns to clear body of indicator, replace air filters.

END OF TASK

**100 kW TACTICAL QUIET GENERATOR SET
ENGINE COOLING SYSTEM MAINTENANCE**

0015 00

THIS WORK PACKAGE COVERS:Inspection
Service

INITIAL SETUP:**Maintenance Level**

Operator

References

None

Tools and Special Tools

None

Materials/Parts

Antifreeze A-A-52624 (item 1, WP 0022 00)

Corrosion inhibitor (item 5, WP 0022 00)

Personnel Required

One

WARNING



Cooling system operates at high temperature and pressure. Contact with high pressure steam and/or liquids can result in burns and scalding. Shut down generator set, and allow system to cool before performing checks, services and maintenance. Failure to comply can cause injury or death to personnel.

INSPECTION

1. On EMCP, set ENGINE CONTROL switch to OFF/RESET.
2. Open all engine access doors.
3. Check fan guards and shroud for dirt and debris blocking air flow.
4. Check radiator and hoses for leaks, loose connections, loose mountings, corrosion, chafing, and missing parts.
5. If coolant level in coolant recovery (overflow) bottle is above HOT line, check for GSC fault HIGH WATER TEMP red indicator flashing (WP 0010 00).
6. Check coolant level at coolant recovery (overflow) bottle. Perform SERVICE if coolant level in recovery (overflow) bottle is below HOT line if coolant is hot or below COLD line if coolant is cold.
7. Close all engine access doors.

END OF TASK

SERVICE

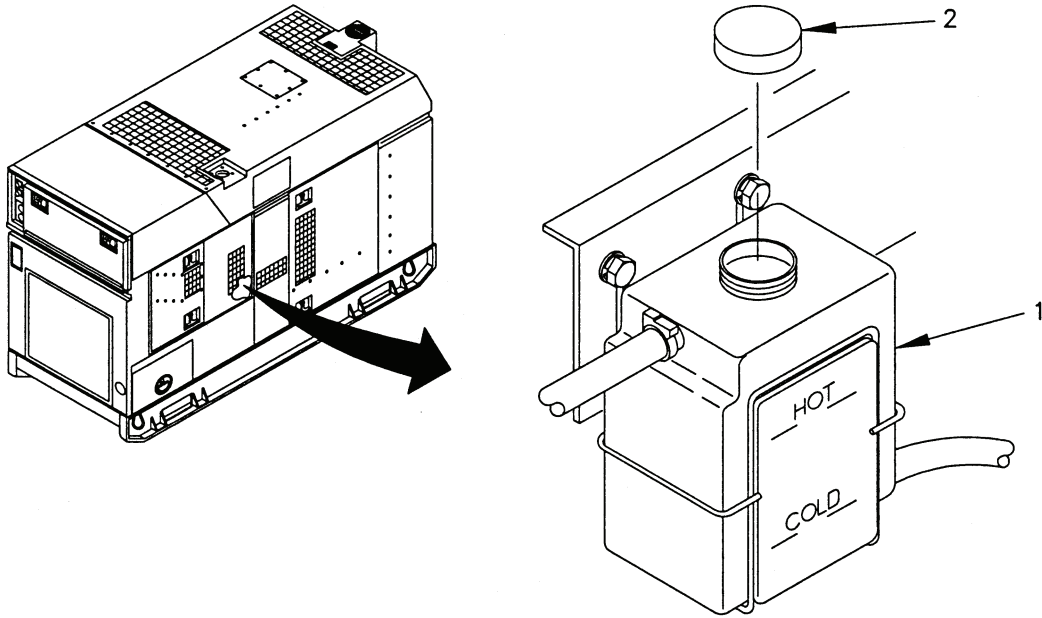

100KW-10-402

1. On EMCP, set ENGINE CONTROL switch to OFF/RESET.
2. Open right side engine access door.
3. Remove cap (2) on coolant recovery (overflow) bottle (1).
4. Fill coolant recovery (overflow) bottle (1) to HOT line if coolant is hot or to COLD line if coolant is cold with proper coolant/antifreeze per Table 1.
5. Install coolant recovery (overflow) bottle cap (2).
6. Close right side engine access door.

Table 1. Coolant.

AMBIENT TEMPERATURE	RADIATOR COOLANT	RATIO	NOTES
-50°F to +120°F (-45.6°C to +49°C)	A-A-52624 antifreeze/water	Antifreeze 60% Water 40%	This offers best freeze protection (-60°F) and best boil protection (+232°F).
+40°F to +120°F (+4°C to +49°C)	Water with MIL-A-53009 corrosion inhibitor	35:1	No freeze or boil protection.

END OF TASK

**100 kW TACTICAL QUIET GENERATOR SET
ENGINE FUEL SYSTEM MAINTENANCE**

0016 00

THIS WORK PACKAGE COVERS:

Inspection
Service

INITIAL SETUP:**Maintenance Level**

Operator

References

None

Tools and Special Tools

None

Materials/Parts

Diesel fuel A-A-52557 1-D
(item 3, WP 0022 00)

Diesel fuel A-A-52557 2-D
(item 4, WP 0022 00)

JP5 per MIL-PRF-5624
(item 16, WP 0022 00)

JP8 per MIL-T-83133
(item 17, WP 0022 00)

Personnel Required

One

WARNING

High voltage is produced when this generator set is in operation. Make sure unit is completely shut down and free of any power source before attempting any repair or maintenance on the unit. Failure to comply can cause injury or death to personnel.

DC voltages are present at generator set electrical components even with generator set shut down. Avoid shorting any positive with ground/negative. Failure to comply can cause injury to personnel and damage to equipment.

WARNING

Diesel fuel is flammable and toxic to eyes, skin, and respiratory tract. Skin and eye protection are required when working in contact with diesel fuel. Avoid repeated or prolonged contact. Provide adequate ventilation. Operators are to wash exposed skin and change chemical soaked clothing promptly if exposed to fuel. Failure to comply can cause injury or death to personnel.

Fuels used in the generator set are flammable. Do not smoke or use open flames when performing maintenance. Failure to comply can result in flames and possible explosion and can cause injury or death to personnel and damage to the generator set.

INSPECTION**Fuel Tank Inspection**

1. Verify that DEAD CRANK SWITCH is set to NORMAL and Battery Disconnect switch is ON.
2. On GSC, set ENGINE CONTROL to COOL DOWN STOP.
3. Check fuel level by observing fuel level indicator.
4. Remove fuel cap (1) and ensure strainer in filler tube (2) is free of dirt and other foreign material. If dirt or debris are present, clean strainer.
5. On EMCP, set ENGINE CONTROL switch to OFF/RESET.

Fuel Filter/Water Separator Inspection

1. On EMCP, set ENGINE CONTROL switch to OFF/RESET.
2. Open front left engine access door.
3. Inspect fuel filter/water separator assembly for proper mounting, cracks, dents, leaks, loose fuel lines, and other damage.
4. Inspect fuel filter/water separator for sediment or water and perform SERVICE procedures if any present.
5. Close front left engine access door.

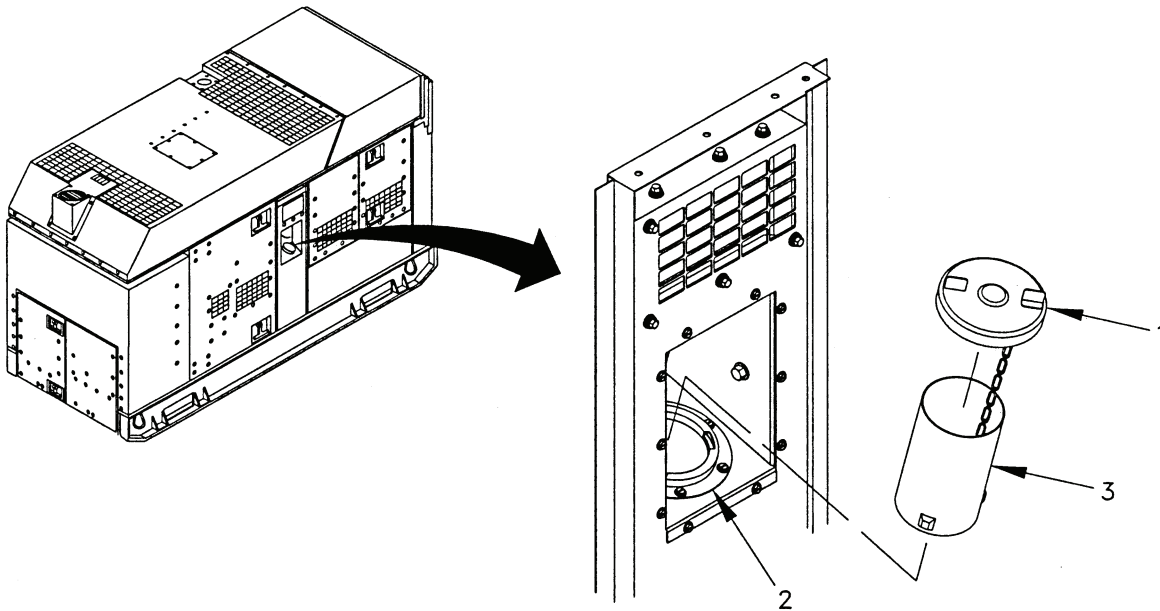

100KW-10-403

END OF TASK

SERVICE**Fuel Tank Service**

Fuels used in the generator set are flammable. When filling the fuel tank, maintain metal-to-metal contact between filler nozzle and fuel tank opening to eliminate static electrical discharge. Failure to comply can result in flames and possible explosion and can cause injury or death to personnel and damage to the generator set.

Hot engine surfaces from the engine and generator circuitry are possible sources of ignition. When hot refueling with DF-1, DF-2, JP5 or JP8, avoid fuel splash and fuel spill. Do not smoke or use open flame when performing refueling. Remember PMCS is still required. Failure to comply can result in flames and possible explosion and can cause injury or death to personnel and damage to the generator set.

NOTE

Fuel tank holds 66 gallons (250L).

The TQG can be refueled while it is operating without stopping the engine and allowing the TQG to cool down. If you are hot refueling, Step 1 is not required.

1. On EMCP, set ENGINE CONTROL switch to OFF/RESET.
2. Remove fuel cap (1).
3. Remove filler tube with strainer (3); clean strainer as necessary and reinstall in filler neck (2).

CAUTION

To prevent damage to the diesel engine, use only specified diesel fuel to service the fuel tank. To prevent condensation of water in fuel tank, always keep level at full. Refer to Table 1 for appropriate fuel.

4. Add diesel fuel to fuel tank per Table 1.
5. Install fuel cap (1).

**100 kW TACTICAL QUIET GENERATOR SET
ENGINE LUBRICATION SYSTEM MAINTENANCE**

0017 00

THIS WORK PACKAGE COVERS:

Inspection
Service

INITIAL SETUP:**Maintenance Level**

Operator

References

None

Tools and Special Tools

None

Materials/Parts

MIL-L-46167 OEA
(item 6, WP 0022 00)
MIL-PRF-2104 OE/HDO-10
(item 7, 8, or 9, WP 0022 00)
MIL-PRF-2104 OE/HDO-30
(item 10 or 11, WP 0022 00)
MIL-PRF-2104 OE/HDO-15/40
(item 12, 13, or 14, WP 0022 00)
MIL-PRF-2104 OE/HDO-40
(item 15, WP 0022 00)

Personnel Required

One

INSPECTION

1. On EMCP, set ENGINE CONTROL switch to OFF/RESET and let cool.
2. Open engine access doors located at front left and right sides of generator set.
3. Inspect engine assembly for oil leaks.
4. Check for damage, proper mounting, or missing parts.

CAUTION

The dipstick is marked so that the crankcase oil can be checked while engine is stopped or running. Always make sure dipstick is checked. Remove oil filler cap when checking oil with engine running.

5. Remove oil dipstick (1) to check engine crankcase oil level. Dipstick is marked on both sides for stopped or running engine. If crankcase oil level is below ADD mark on dipstick, for either stopped or running engine, perform SERVICE task.
6. Close both engine access doors.

END OF TASK**SERVICE**

1. On EMCP, set ENGINE CONTROL switch to OFF/RESET and let engine cool.
2. Open right engine access door.
3. Remove oil filler cap (2).
4. Add oil to engine crankcase for operations temperature range per Table 1.

**100 kW TACTICAL QUIET GENERATOR SET
PREPARATION FOR STORAGE OR SHIPMENT**

0018 00

PRESERVATION

There are no special preservation requirements. The generator set should be started and run until operating temperature is reached a minimum of every 60 days and ideally every 30 days. If the generator set is not going to be started for over 60 days, recommend you contact the Army Material Command Major Subordinate Command responsible for Generators to obtain special maintenance, storage and preservation requirements and procedures.

PACKING

There are no special packaging requirements.

MARKING

Mark for shipment or storage in accordance with MIL-STD-129.

USE OF CORROSION-PREVENTIVE COMPOUNDS, MOISTURE BARRIERS, AND DESICCANT MATERIALS

Refer to Corrosion Prevention and Control, TB 43-0213.

SPECIAL INSTRUCTIONS FOR ADMINISTRATIVE STORAGE

Placement of equipment in administrative storage should be for short periods of time when a shortage of maintenance effort exists. Items should be in mission readiness within 24 hours or within the time factors as determined by the directing authority.

Before placing the equipment in administrative storage, current preventive maintenance checks and services should be completed, shortcomings and deficiencies should be corrected, and all Modification Work Orders (MWO), Modification Instructions (MI) or Time Compliance Technical Orders (TCTO) should be applied.

Inside storage is preferred for items selected for administrative storage. If inside storage is not available, trucks, vans, CONEX containers, and other containers may be used.

For storage information, refer to TM 740-90-1/TO 35-1-4.

END OF TASK

CHAPTER 5
SUPPORTING INFORMATION
FOR
100 kW TACTICAL QUIET GENERATOR SET

CHAPTER 5

SUPPORTING INFORMATION
FOR
100 kW TACTICAL QUIET GENERATOR SET

WORK PACKAGE INDEX

<u>Title</u>	<u>WP Sequence No.</u>
REFERENCES	0019 00
COMPONENTS OF END ITEM (COEI) AND BASIC ISSUE ITEMS (BII) LISTS.....	0020 00
ADDITIONAL AUTHORIZED LIST (AAL)	0021 00
EXPENDABLE AND DURABLE ITEMS LIST	0022 00
WARRANTY INFORMATION.....	0023 00

**100 kW TACTICAL QUIET GENERATOR SET
REFERENCES**

SCOPE

This work package lists all field manuals, forms, technical manuals, technical bulletins, commercial manuals, and miscellaneous publications for use with the Tactical Quiet Generator.

FIELD MANUALS

Chemical and Biological Contamination Avoidance.....	FM 3-3
NBC Protection.....	FM 3-4
NBC Decontamination.....	FM 3-5
Camouflage.....	FM 5-20
First Aid	FM 4-25.11
Operation and Maintenance of Ordnance Materiel in Cold Weather (0° to -65°).....	FM 9-207
Techniques of Military Instruction	FM 21-6
Military Symbols	FM 21-30
Chemical, Biological, Radiological, and Nuclear Defense.....	FM 21-40
Manual for Wheeled Vehicle Driver.....	FM 21-305
Basic Cold Weather Manual	FM 31-70
Northern Operations	FM 31-71
Mountain Operations	FM 90-6

FORMS

Technical Order Publication Improvement Report.....	AFTO Form 22
Recommended Changes to Publications and Blank Forms.....	DA Form 2028
Recommended Changes to Equipment Technical Publications.....	DA Form 2028-2
Recommended Changes to Publications and Blank Forms.....	NAVMC 10772
Hand Receipt	DA Form 2062
Equipment Inspection and Maintenance Worksheet.....	DA Form 2404
Maintenance Request.....	DA Form 2407
Equipment Log Assembly (Records).....	DA Form 2408
Equipment Control Record	DA Form 2408-9
Oil Analysis Log.....	DA Form 2408-20
Equipment Inspection and Maintenance Worksheet.....	DA Form 5988-E
Preventive Maintenance Schedule and Record.....	DD Form 314
Accident Identification Card.....	DD Form 518
Processing and Deprocessing Record for Shipment, Storage, and Issue of Vehicles and Spare Engines.....	DD Form 1397
Consolidated Engineer Equipment Operations Log and Service Record.....	NAVMC10524
Worksheet for Quarterly Preventive Maintenance and Technical Inspection for Engineer Equipment	NAVMC10560
Tracking Program	NAVMC 10772
Motor Vehicle Accident Report.....	SF Form 91
Transportation Discrepancy Report	SF Form 361
Product Quality Deficiency Report.....	SF Form 368

MISCELLANEOUS PUBLICATIONS

Army Logistics Readiness and Sustainability.....	AR 700-138
Reporting of Supply Discrepancies	AR 735-11-2
Army Materiel Maintenance Policy and Retail Maintenance Operations.....	AR 750-1
Procedures for Destruction of Electronics Materiel to Prevent Enemy Use	AR 750-244-2
Army Medical Department Expendable/Durable Items.....	CTA 8-100
Expendable Items (Except Medical Class V, Repair Parts, and Heraldic Items).....	CTA 50-970
Operator's Circular, Welding Theory and Application.....	TC 9-237

**100 kW TACTICAL QUIET GENERATOR SET
REFERENCES – Continued**

0019 00

PAMPHLETS

Consolidated Index of Publications and Blank Forms DA PAM 25-30
 Functional Users Manual for the Army Maintenance Management System (TAMMS) DA PAM 738-750

TECHNICAL BULLETINS

Color, Marking, and Camouflage Painting of Military Vehicles, Construction
 Equipment, and Materials Handling Equipment TB 43-0209
 Corrosion Prevention and Control TB 43-0213
 Description, Use, Bonding Techniques, and Properties of Adhesives TB ORD 1032

MILITARY STANDARDS AND SPECIFICATIONS

Lubricating Oil, Internal Combustion Engine, Combat/Tactical Service MIL-PRF-2104
 Lubricating Oil, Internal Combustion Engine, Preservative and Break-In MIL-L-21260
 Lubricating Oil, Internal Combustion Engine, Arctic MIL-L-46167
 Fuel Oil, Diesel A-A-52557
 Turbine Fuels, Aviation, Kerosene Types NATO F-34 (JP-8),
 NATO F-35, and JP-8+100 MIL-DTL 83133E
 Requirements for the Certification of Sling Loaded Military Equipment for External
 Transportation by Department of Defense Helicopters MIL-STD-913

DEPARTMENT OF DEFENSE (DOD) STANDARDS

Department of Defense Materiel Management Regulations DOD 4100-1-R
 FLIS Program Manual DOD 4100-39-M

TECHNICAL MANUALS

Chemical, Biological, and Radiological (CBR) Decontamination TM 3-220
 Inspection, Care, and Maintenance of Antifriction Bearings TM 9-214
 Deepwater Fording of Ordnance Material TM 9-238
 Materials Used for Cleaning, Preserving, Abrading, and Cementing Ordnance
 Material and Related Material Including Chemicals TM 9-247
 Painting Instructions for Army Materiel TM 43-0139
 Installation Practices for Aircraft Electrical and Electronic Wiring TM 55-1500-323-24
 Administrative Storage of Equipment TM 740-90-1/TO 35-1-4
 Procedures for Destruction of Electronics Materiel to Prevent Enemy Use TM 750-244-2
 Unit, Direct and General Support Maintenance Manual for
 Tactical Quiet Generator Set, Skid Mounted, 100 kW,
 50/60 Hz MEP-807A and Tactical Quiet Generator Set, Trailer
 Mounted, 100 kW, 50/60 Hz, PU-807A TM 9-6115-729-24
 Repair Parts and Special Tools List for
 Tactical Quiet Generator Set, Skid Mounted, 100 kW,
 50/60 Hz MEP-807A and Tactical Quiet Generator Set, Trailer
 Mounted, 100 kW, 50/60 Hz, PU-807A TM 9-6115-729-24P
 Operator's, Organizational, DS, and GS Maintenance Manual Including Repair Parts
 and Special Tools Lists for Trailer, 5-Ton, 4-Wheel, GEMSS, XM979;
 Trailer, Flatbed: 5-Ton, 4-Wheel, XM1061/M1061A1; and Trailer, General
 Purpose, Flatbed: 7-1/2-Ton, XM1073 TM 9-2330-376-14&P

**100 kW TACTICAL QUIET GENERATOR SET
COMPONENT OF END ITEM (COEI) AND BASIC ISSUE ITEMS (BII) LISTS**

0020 00

INTRODUCTION

Scope

This work package contains COEI and BII information for the 100 kW Tactical Quiet Generator Set MEP-807A and Power Unit PU-807A to help you inventory items for safe and efficient operation of the equipment.

General

The COEI and BII information is divided into the following:

COEI. This list (Table 1) is for information purposes only and is not authority to requisition replacements. These items are part of the 100 kW Tactical Quiet Generator (MEP-807A and Power Unit (PU-807A)). As part of the end item, these items must be with the end item whenever it is issued or transferred between property accounts. Items of COEI are removed and separately packaged for transportation or shipment only when necessary. Illustrations are furnished to help you find and identify the items.

BII. This list (Table 2) provides essential items required to place the 100 kW Tactical Quiet Generator Set (MEP-807A and Power Unit (PU-807A)) in operation, to operate it, and to do emergency repairs. Although shipped separately packaged, BII must be with the 100 kW Tactical Quiet Generator Set during operation and when it is transferred between property accounts. This list is your authority to request/requisition them for replacement based on authorization of the end item by the Table of Organization and Equipment/ Modified Table of Organization and Equipment (TOE/MTOE). Illustrations are furnished to help you find and identify the items.

COEI LIST AND BII LISTS COLUMN DESCRIPTIONS (TABLES 1 AND 2)

Column (1) – ILLUS NUMBER. Identifies the number of the item illustrated.

Column (2) – NATIONAL STOCK NUMBER. Identifies the stock number of the item to be used for requisitioning purposes.

Column (3) – DESCRIPTION, CAGEC, AND PART NUMBER . Identifies the Federal item name (in all capital letters) followed by a minimum description when needed. The stowage location of COEI and BII is also included in this column. The last line below the description is the CAGEC (commercial and Government entity code) (in parentheses), and the part number.

Column (4) – USABLE ON CODE. When applicable, gives a code if the item you need is not the same for different models of equipment. These codes are identified below:

<u>Code</u>	<u>Used On</u>
49M	MEP-807A
78B	PU-807A

Column (5) –U/M. Indicates the unit of measure or count of the item as issued per the National Stock Number shown in column (2).

Column (6) – QTY REQ. Indicates the quantity required.

**100 kW TACTICAL QUIET GENERATOR SET
COMPONENT OF END ITEM (COEI) AND BASIC ISSUE ITEMS (BII) LISTS – Continued**

0020 00

COEI LIST

Table 1. Components of End Item List.

(1) ILLUS NUMBER	(2) NATIONAL STOCK NUMBER	(3) DESCRIPTION, CAGEC, AND PART NUMBER	(4) USABLE ON CODE	(5) U/M	(6) QTY REQ
1	6115-01-296-1463	GENERATOR SET (30554) MEP 807A	49M	EA	1
2	6115-01-471-7088	POWER UNIT (30554) PU 807A	78B	EA	1
3	2330-01-207-3533	5 TON TRAILER, MODEL XM1061E, FLAT BED (MODIFIED) (93742) 0116-1945	78B	EA	1
4	2540-01-417-8036	ACCESSORY BOX	78B	EA	1
5		BRACKET, FIRE EXTINGUISHER, 5 LB (97403) 13230E6858	78B	EA	2
6		TAG, INSTRUCTION, GROUND TERMINAL (30554) 02-23013	78B	EA	1
7	5940-00-237-2703	TERMINAL LOAD (30554) 69-692-4	78B	EA	1

100 kW TACTICAL QUIET GENERATOR SET
COMPONENT OF END ITEM (COEI) AND BASIC ISSUE ITEMS (BII) LISTS – Continued

0020 00

COEI LIST – Continued

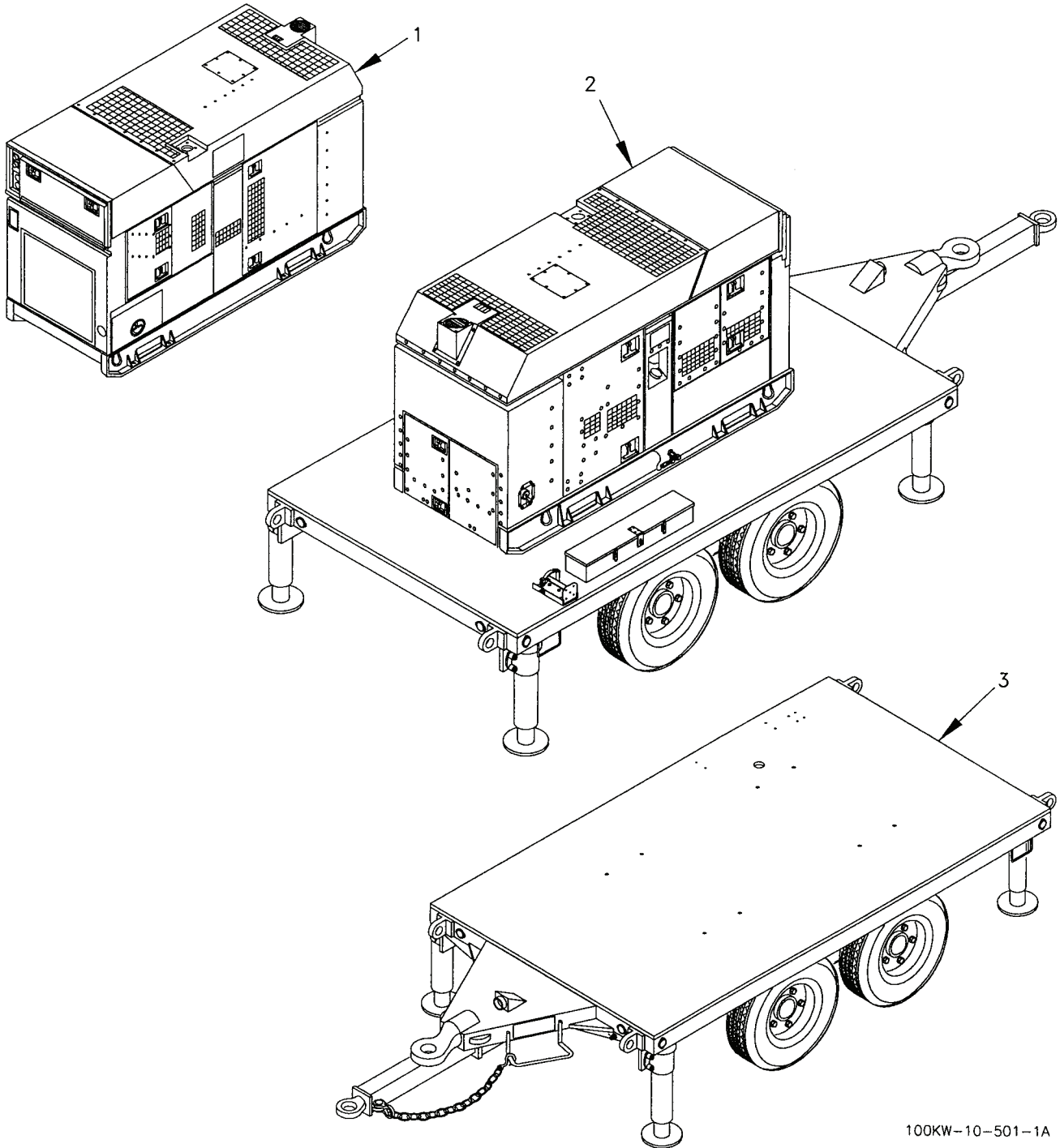

100KW-10-501-1A

100 kW TACTICAL QUIET GENERATOR SET
 COMPONENT OF END ITEM (COEI) AND BASIC ISSUE ITEMS (BII) LISTS – Continued

0020 00

COEI LIST – Continued

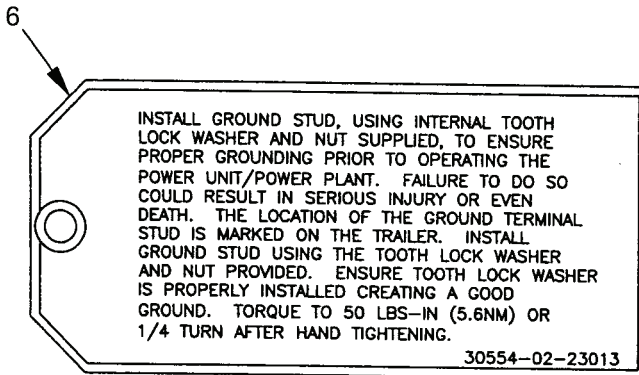
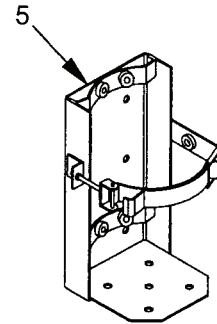
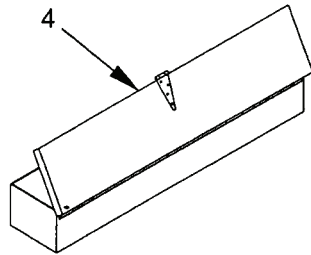

100KW-10-501-2A

**100 kW TACTICAL QUIET GENERATOR SET
COMPONENT OF END ITEM (COEI) AND BASIC ISSUE ITEMS (BII) LISTS – Continued**

0020 00

BII LIST

Table 2. Basic Issue Items List.

(1) ILLUS NUMBER	(2) NATIONAL STOCK NUMBER	(3) DESCRIPTION, CAGEC, AND PART NUMBER	(4) USABLE ON CODE	(5) U/M	(6) QTY REQ
1	4730-01-340-7594	ADAPTER, STRAIGHT, PIPE TO HOSE (1KPD5) 125-HBL-10-12	78B	EA	1
2	4730-00-908-3194	CLAMP, HOSE (96906) MS35842-11	78B		
3	6625-01-476-1432	COMMUNICATION ADAPTER II GROUP (11083) 171-4400 CONSISTING OF COMMUNICATION ADAPTER II, (11083) 171-4401 CABLE, SERIAL PC (11083) 196-0055 CABLE, DATA LINK (11083) 160-0133 CARRYING CASE (11083) 6V3072 COMMUNICATION ADAPTER II CD AND USER'S MANUAL (11083) NEHS0758	49M, 78B	EA	1
	8145-01-375-6285				
4	5120-01-013-1676	DRIVER/PULLER, GROUND ROD (97403) 13226E7741	78B	EA	1
5	4730-00-809-9703	ELBOW, PIPE TO HOSE (97403) 13230E6380-4	78B	EA	1
6		ELECTRONIC TECHNICIAN SOFTWARE LICENSE AND ONE-TIME ONLY SUBSCRIPTION (11083) NEXG5039	49M, 78B	EA	1
7	7030-01-488-3978	ELECTRONIC TECHNICIAN SOFTWARE (11083) JEBD3003	49M, 78B	EA	1
8	4210-00-361-6921	EXTINGUISHER, FIRE, CARBON DIOXIDE, 5 LB (54905) 322	78B	EA	2

**100 kW TACTICAL QUIET GENERATOR SET
COMPONENT OF END ITEM (COEI) AND BASIC ISSUE ITEMS (BII) LISTS – Continued**

0020 00

BII LIST – Continued

Table 2. Basic Issue Items List – Continued.

(1) ILLUS NUMBER	(2) NATIONAL STOCK NUMBER	(3) DESCRIPTION, CAGEC, AND PART NUMBER	(4) USABLE ON CODE	(5) U/M	(6) QTY REQ
9	5120-00-251-4489	HAMMER, HAND, ENGINEERS, DOUBLE FACE, 8 LB (58536) A-A-1293	78B	EA	1
10		HOSE ASSEMBLY, NONMETALLIC: FUEL AND OIL (97403) 13230E6381	78B	EA	1
11		HOSE, NONMETALLIC (30554) 88-20580-5	78B	AR	1
12		LAMINATE, PLASTIC (REFERENCE DATA) (93742) 0116-1912	49M, 78B	EA	1
13	4720-00-021-3320	LINE, FUEL, AUXILIARY (30554) 69-668	49M, 78B	EA	1
14	4710-00-185-6948	PIPE (97403) 13211E7543	78B	EA	1
15	4710-00-597-8731	PIPE, EXTENSION (97403) 13211E7542	78B	EA	1
16	5975-00-878-3791	RODS, GROUND (WITH ATTACHMENTS), SECTIONAL 9 FT (58536) AA55804-III-B	49M, 78B	EA	1
17		TECHNICAL MANUAL TM 9-2330-376-14&P, PIN 064498	78B	EA	1
18		TECHNICAL MANUAL TM 9-6115-729-10, PCN 182 074642 00	49M, 78B	EA	1
19		TECHNICAL MANUAL TM 9-6115-729-24, PCN 182 074643 00	49M, 78B	EA	1
20		TECHNICAL MANUAL TM 9-6115-729-24P, PCN 182 074644 00	49M, 78B	EA	1
21	6150-01-406-9533	PARALLELING CABLES (30554) 88-22209	49M, 78B	EA	1
22	5120-01-369-1646	WRENCH, LOAD TERMINAL (30544) 88-21148	49M, 78B	EA	1

100 kW TACTICAL QUIET GENERATOR SET
COMPONENT OF END ITEM (COEI) AND BASIC ISSUE ITEMS (BII) LISTS – Continued

0020 00

BII LIST – Continued

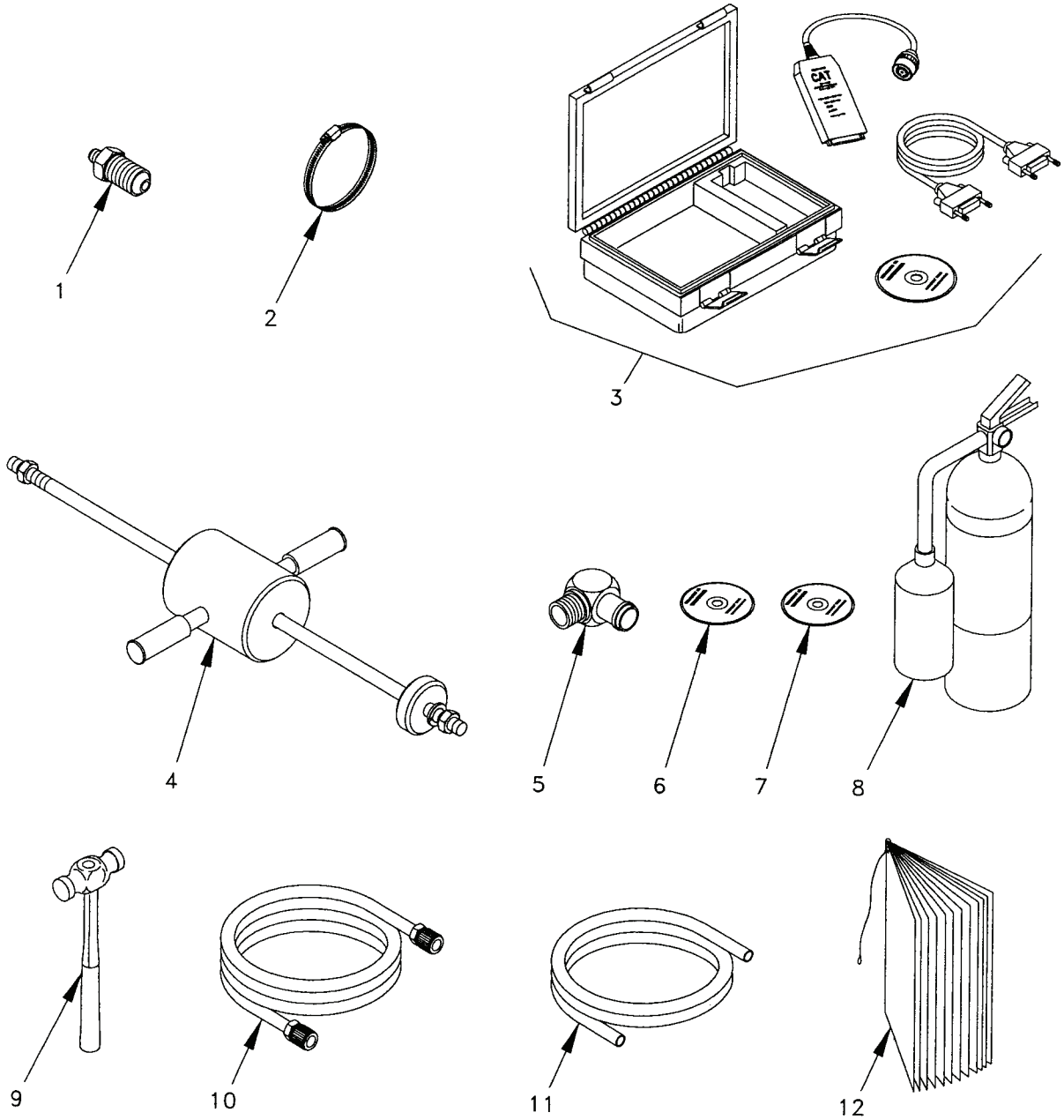

100KW-10-505-1A

100 kW TACTICAL QUIET GENERATOR SET
 COMPONENT OF END ITEM (COEI) AND BASIC ISSUE ITEMS (BII) LISTS – Continued

0020 00

BII LIST – Continued

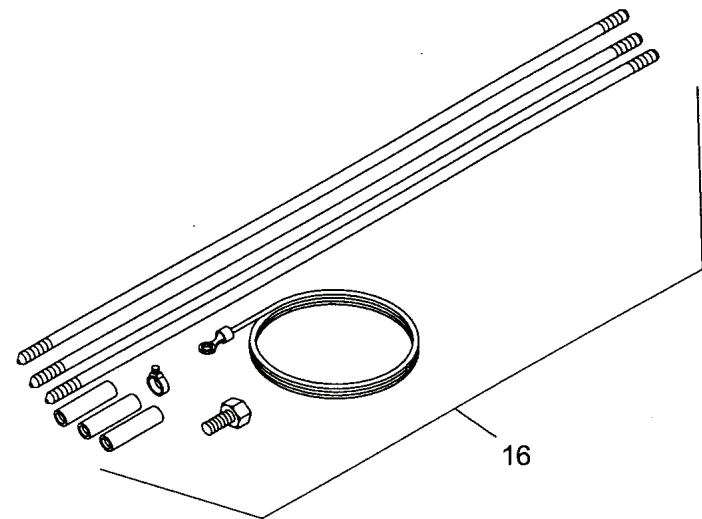
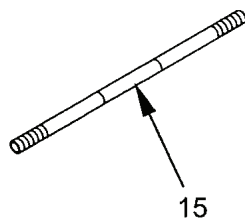
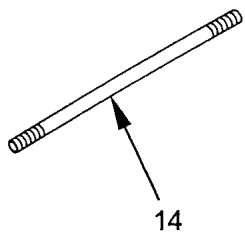
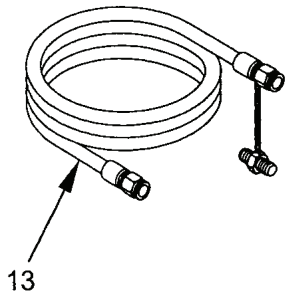

18

17

TM 9-2330-376-14&P

TECHNICAL MANUAL

OPERATOR'S, ORGANIZATIONAL, DIRECT SUPPORT
 AND GENERAL SUPPORT MAINTENANCE MANUAL
 (INCLUDING REPAIR PARTS AND SPECIAL TOOLS LISTS)
 FOR
 CHASSIS, TRAILER: 5-TON, 4-WHEEL, GEMSS
 XM879 (NSN 2330-01-170-4747)
 TRAILER, FLATBED: 5-TON, 4-WHEEL
 XM1061 (NSN 2330-01-297-3533)
 M1061A1 (NSN 2330-01-297-3533)
 TRAILER, GENERAL PURPOSE, FLATBED: 7-1/2-TON
 XM1073 (NSN 2330-01-287-8111)

Quantity	31
Disposition	31
Part	31
Labeling	31
Identification	31
Classification	31
Storage	31
Display	31
Operational	31
Performance	31
Availability	31
Repair Parts and Special Tools (See Part 1)	31

This manual supersedes TM 9-2330-376-14&P, dated 28 June 1985, including all changes.
 Approved for public release; distribution is unlimited.

HEADQUARTERS, DEPARTMENT OF THE ARMY MARCH 1992

ARMY TM 9-6115-729-10
 AIR FORCE TO 35C2-3-519-1
 NAVY AIR 15-50-26
 MARINE CORPS TM 07464C-10

TECHNICAL MANUAL

OPERATOR'S MANUAL
 FOR
 GENERATOR SET, SKID MOUNTED, TACTICAL QUIET
 100 kW, 50/60 Hz
 MEP-807A
 NSN 6115-01-296-1463 (EIC: XXX)
 GENERATOR SET, TRAILER MOUNTED, TACTICAL QUIET
 100 kW, 50/60 Hz
 PU-807A
 NSN 6115-01-471-7088 (EIC: XXX)

OFFICIAL USE ONLY - Approved for public release; distribution is unlimited.

HEADQUARTERS, DEPARTMENTS OF THE ARMY,
 AIR FORCE, NAVY, AND HEADQUARTERS U.S. MARINE CORPS
FORM 154225-02 - Published by permission of copyright owner, based on previous editions.

15 MARCH 2005
 POC: 142 87442 00

100KW-10-505-2C

100 kW TACTICAL QUIET GENERATOR SET
 COMPONENT OF END ITEM (COEI) AND BASIC ISSUE ITEMS (BII) LISTS – Continued

0020 00

BII LIST – Continued

ARMY TM 9-6115-729-24
 AIR FORCE TO 35C2-3-619-2
 NAVAIR 19-50-27
 MARINE CORPS TM 07464C-242

TECHNICAL MANUAL
 UNIT, DIRECT SUPPORT, AND GENERAL SUPPORT MAINTENANCE
 MANUAL
 FOR
 GENERATOR SET, SKID MOUNTED, TACTICAL QUIET
 100 kW, 50/60 Hz
 MEP-807A
 NSN 6115-01-296-1463 (EIC: KP1)
 GENERATOR SET, TRAILER MOUNTED, TACTICAL QUIET
 100 kW, 50/60 Hz
 PU-807A
 NSN 6115-01-471-7088 (EIC: KPB)

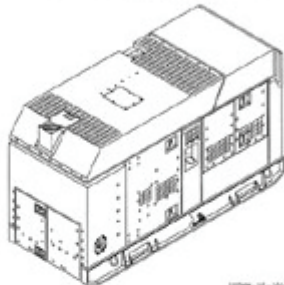

10000-10-101A

DISTRIBUTION STATEMENT A – Approved for public release; distribution is unlimited.

**HEADQUARTERS, DEPARTMENTS OF THE ARMY,
 AIR FORCE, NAVY, AND HEADQUARTERS U.S. MARINE CORPS**
ISSUE STATEMENT – Published by Direction of Commander, Naval Air Systems Command

DATE – TBD
 PCN 182 074643 00

19

20

ARMY TM 9-6115-729-24P
 AIR FORCE TO 35C2-3-619-2
 NAVAIR 19-50-30
 MARINE CORPS TM 07464C-24P/3

TECHNICAL MANUAL
 UNIT, DIRECT SUPPORT, AND GENERAL SUPPORT
 MAINTENANCE REPAIR PARTS AND SPECIAL TOOLS LIST
 FOR
 GENERATOR SET, SKID MOUNTED, TACTICAL QUIET
 100 kW, 50/60 Hz
 MEP-807A
 NSN 6115-01-296-1463 (EIC: KP1)
 GENERATOR SET, TRAILER MOUNTED, TACTICAL QUIET
 100 kW, 50/60 Hz
 PU-807A
 NSN 6115-01-471-7088 (EIC: KPB)

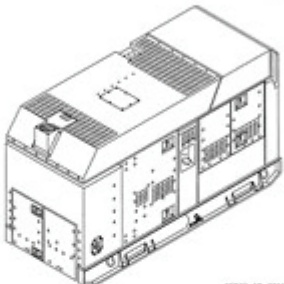

10000-10-101A

DISTRIBUTION STATEMENT A – Approved for public release; distribution is unlimited.

**HEADQUARTERS, DEPARTMENTS OF THE ARMY,
 AIR FORCE, NAVY, AND HEADQUARTERS U.S. MARINE CORPS**
ISSUE STATEMENT – Published by Direction of Commander, Naval Air Systems Command

DATE – TBD
 PCN 182 074644 00

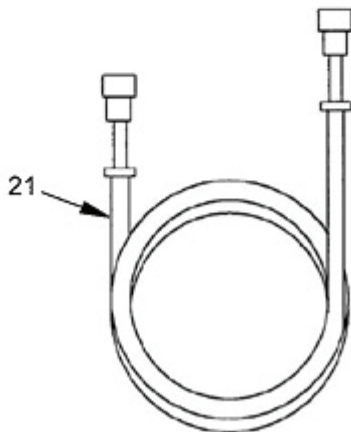

**100 kW TACTICAL QUIET GENERATOR SET
ADDITIONAL AUTHORIZED LIST (AAL)**

0021 00

INTRODUCTION

Scope

This work package lists additional items you are authorized for the support of the 100 kW Tactical Quiet Generator Set.

General

The AAL (Table 1) identifies items that do not have to accompany the 100 kW Tactical Quiet Generator Set and that do not have to be turned in with it. These items are all authorized to you by Common Table of Allowances (CTA), MTOE, Table of Distribution and Allowances (TDA), or Joint Table of Allowances (JTA).

AAL COLUMN DESCRIPTIONS (TABLE 1)

Column (1) – NATIONAL STOCK NUMBER. This column identifies the stock number of the item to be used for requisitioning purposes.

Column (2) – DESCRIPTION, PART NUMBER, AND CAGE. Identifies the Federal item name (in all capital letters) followed by a minimum description when needed. The last line below the description is the CAGE, in parentheses, and the part number.

Column (3) – USABLE ON CODE. When applicable, gives a code if the item you need is not the same for different models of equipment.

Column (4) – U/M. Indicates the unit of measure or count of the item as issued per the National Stock Number shown in column (1).

Column (5) – QTY RECM. Indicates the quantity recommended.

AAL

Table 1. Additional Authorized List.

(1) NATIONAL STOCK NUMBER	(2) DESCRIPTION, CAGEC, AND PART NUMBER	(3) USABLE ON CODE	(4) U/M	(5) QTY RECM
5975-00-878-3791	RODS, GROUND (WITH ATTACHMENTS), SECTIONAL 9 FT (58536) AA55804-III-B	49M, 78B	EA	1
5975-00-794-2523	COUPLINGS, (THREE IN SET)	49M, 78B	EA	1
5975-00-924-9927	DRIVE/HEAD STUD	49M, 78B	EA	1
6145-00-395-8799	WIRE, ELECTRICAL, NO. 6 AWG, 7 STRANDS, CLASS B, TEMPER, 6FT LONG ASTM B8	49M, 78B	EA	1
5999-00-186-3912	CLAMP	49M, 78B	EA	1
5940-00-271-9504	GROUND TERMINAL LUG	49M, 78B	EA	1
5310-01-477-1264	WASHER, FLAT (30554) 88-20564-15	49M, 78B	EA	1
5310-01-365-5788	NUT, SELF LOCKING HEXAGON, PREVAILING TORQUE (30554) 88-21930-2	49M, 78B	EA	1

**100 kW TACTICAL QUIET GENERATOR SET
ADDITIONAL AUTHORIZED LIST (AAL) – Continued**

0021 00

AAL – Continued

Table 1. Additional Authorized List. - Continued

(1) NATIONAL STOCK NUMBER	(2) DESCRIPTION, CAGEC, AND PART NUMBER	(3) USABLE ON CODE	(4) U/M	(5) QTY RECM
2540-01-519-5517	WINTERIZATION KIT (93742) 0116-1810	49M, 78B	EA	1
5120-01-013-1676	HAMMER, SLIDE (45225) P74-144	49M, 78B	EA	1
4210-00-361-6921	EXTINGUISHER, FIRE, CARBON DIOXIDE, 5 LB (54905) 322	78B	EA	1
5342-00-066-1235	ADAPTER, CONTAINER (97403) 13211E7541	78B	EA	1
4710-00-185-6948	PIPE (97403) 13211E7543	78B	EA	1
4710-00-597-8731	PIPE, EXTENSION (97403) 1311E7542	78B	EA	1
7240-00-222-3088	FUEL CAN	78B	EA	1
7240-00-177-6154	FLEXIBLE SPOUT	78B	EA	1

**100 kW TACTICAL QUIET GENERATOR SET
EXPENDABLE AND DURABLE ITEMS LIST**

0022 00

INTRODUCTION

This work package lists expendable and durable items that you will need to operate and maintain the 100 kW Tactical Quiet Generator Set. This list is for information only and is not authority to requisition the listed items. These items are authorized to you by CTA 50-970, Expendable/Durable Items (Except Medical, Class V Repair Parts, and Heraldic Items) or CTA 8-100, Army Medical Department Expendable/Durable Items.

EXPANDABLE AND DURABLE ITEMS LIST COLUMN DESCRIPTIONS (TABLE 1)

Column (1) – ITEM NUMBER. This column gives you a number assigned to the entry in the list, and the number is referenced in the narrative instructions to identify the item, e.g., “Use antifreeze (item 1, WP 0022 00).”

Column (2) – LEVEL. This column includes the lowest level of maintenance that requires the listed item (C = Operator/Crew).

Column (3) – NATIONAL STOCK NUMBER. This column identifies the stock number of the item to be used for requisitioning purposes.

Column (4) – ITEM NAME, DESCRIPTION, PART NUMBER, AND CAGE. This column provides the other information you need to identify the item.

Column (5) –U/M. This column provides the units of measure or count of an item, such as gallon, dozen, gross, etc.

**100 kW TACTICAL QUIET GENERATOR SET
EXPENDABLE AND DURABLE ITEMS LIST – Continued**

0022 00

EXPENDABLE AND DURABLE ITEMS LIST

Table 1. Expendable and Durable Items List.

(1) ITEM NUMBER	(2) LEVEL	(3) NATIONAL STOCK NUMBER	(4) ITEM NAME, DESCRIPTION, CAGEC, AND PART NUMBER	(5) U/M
1	C	6850-00-664-1403	Antifreeze, 1 gallon, (58536) A-A-52624	GL
2	C	7930-01-306-8369	Cleaning Compound, Simple Green, 1 gallon, (1Z575)	BX
3	C	9140-00-286-5288	Fuel Oil, Diesel , 1-D, 55 gallon, (58536) A-A-52557	DR
4	C	9140-00-286-5296	Fuel Oil, Diesel , 2-D, 55 gallon, (58536) A-A-52557	DR
5	C	6850-01-287-8067	Inhibitor, Corrosion, Liquid Cooling System, , 1 gallon, (81349) MIL-A-53009	GL
6	C	9150-01-402-4478	Lubricating Oil, Internal Combustion Engine, Arctic, OEA, (81349) MIL-L-46167	QT
7	C	9150-00-189-6727	Lubricating Oil, Internal Combustion Engine, OE/HDO-10, 1 quart, (81349) MIL-PRF-2104	QT
8	C	9150-00-183-7807	Lubricating Oil, Internal Combustion Engine, OE/HDO-10, 1 gallon, (81349) MIL-PRF-2104	GL
9	C	9150-00-186-6668	Lubricating Oil, Internal Combustion Engine, OE/HDO-10, 5 gallon, (81349) MIL-PRF-2104	CN
10	C	9150-00-186-6681	Lubricating Oil, Internal Combustion Engine, OE/HDO-30, 1 quart, (81349) MIL-PRF-2104	QT
11	C	9150-00-188-9858	Lubricating Oil, Internal Combustion Engine, OE/HDO-30, 5 gallon, (81349) MIL-PRF-2104	CN
12	C	9150-01-152-4117	Lubricating Oil, Internal Combustion Engine, OE/HDO-15/40, 1 quart, (81349) MIL-PRF-2104	QT
13	C	9150-01-213-3118	Lubricating Oil, Internal Combustion Engine, OE/HDO-15/40, 1 gallon, (81349) MIL-PRF-2104	GL
14	C	9150-01-152-4119	Lubricating Oil, Internal Combustion Engine, OE/HDO-15/40, 55 gallon, (81349) MIL-PRF-2104	CN
15	C	9150-00-405-2987	Lubricating Oil, Internal Combustion Engine, OE/HDO-40, 1 gallon, (81349) MIL-PRF-2104	GL
16	C	9130-00-273-2379	Turbine Fuel, Aviation, 55 gallon, (58536) MIL-PRF-5624, JP5	DR
17	C	9130-01-031-5816	Turbine Fuel, Aviation, (81349) MIL-T-83133, JP8	GL
18	C	7920-00-205-3571	Wiping Rag, Cotton and Cotton Synthetic, (81348) DDD-R-0030, Grade B	BX

**100 kW TACTICAL QUIET GENERATOR SET
WARRANTY INFORMATION**

0023 00

INTRODUCTION

This appendix provides information on the Warranty for generator set components. See Table One for list of warranted components.

NOTE.

Check the Insp Date on the end-item data plate on the generator set. If the Insp Date is prior to 09/06, the (12) month Warranty period shall begin on 08/31/06.

If the Insp Date on the data plate is 09/06 or after, the standard (12) month Warranty begins on the date stamped.

Warranty service may be obtained through the following methods:

1. a. (ARMY ONLY) Fill out the preferred warranty claim SF 368, Product Quality Deficiency Report, or fill out a warranty claim per DA PAM 738-750. The DA Form 2407, Maintenance Request, is also acceptable. Mail completed form to Commander, US Army, Communications-Electronics Life Cycle Management Command, ATTN: AMSEL-LC-CCS-G-GN, 1200 Nealis Avenue, Fort Monmouth, New Jersey 07703-5043. At a minimum, the end item NSN, serial number, and date of shipment to the government, and the defective component part number/CAGE must be included in the documentation.
 - b. (OTHER SERVICES) For reporting warranty claims, fill out and forward SF 368 or DA Form 2407 to US Army Communications-Electronics Life Cycle Management Command, ATTN: AMSEL-LC-CCS-G-GN, 1200 Nealis Avenue, Fort Monmouth, NJ 07703-5043.
2. Warranty service can be obtained by contacting the actual warranted component manufacturer listed in column 1. Each manufacturer will provide instructions on filing the claim.
3. Troubleshooting should be performed to the level of warranted component, but no further unless directed by the warranted component manufacturer. Troubleshooting to the failed part inside warranted components may invalidate the warranty.
4. There are some components with short warranty periods that may not be listed in Table 1. Warranty coverage may be available for these components. Submit warranty claims in accordance with DA PAM 738-750 to determine if the components are covered.
5. If you have difficulty with or questions about the warranty process, contact your local CECOM LAR or the CECOM Generator Branch, DSN 992-1313, (732) 532-1313.

MANUFACTURER WARRANTY INFORMATION

Column (1) – MANUFACTURER. This column gives you the name and address of the manufacturer of a component under warranty. Telephone numbers, fax numbers, and internet addresses are listed where available.

Column (2) – COMPONENT UNDER WARRANTY. This column describes the component under warranty with part number (PN) and vendor part number VPN where available.

Column (3) –WARRANTY PERIOD. This column lists the length of the warranty period.

**100 kW TACTICAL QUIET GENERATOR SET
WARRANTY INFORMATION – Continued**

0023 00

MANUFACTURER WARRANTY INFORMATION – Continued

Table 1. Manufacturer’s Warranties for 100 kW Generator Set.

(1) MANUFACTURER	(2) COMPONENT UNDER WARRANTY	(3) WARRANTY PERIOD
Caterpillar, Inc. Defense Products Engine Service Engineer PO Box 470 Mossville, IL 61552-0470 Phone: 309-578-4562 Fax: 309-578-3739 CAGE: 11083	Diesel Engine (PN: 0116-1110, VPN: 211-9442) <u>Digital Control System Components</u> GSC+P Controller (PN: 0116-1201-41, VPN: 198-9253) Alarm Module (PN: 0116-1201-34, VPN: 130-3324)	12 Months
Warranty repairs can also be obtained through any Caterpillar dealer. Nearest dealer can be located at www.cat.com	Digital Voltage Regulator (PN: 0116-1201-37, VPN: 155-3832) Load Sharing Module (PN: 0116-1201-39, VPN: 161-0797) Transformer (PN: 0116-1201-32, VPN: 118-0175) Transformer (PN: 0116-1201-40, VPN: 169-4701) Harness Assembly (PN: 0116-1201-43, VPN: 212-8737)	12 Months
Marathon Electric P.O. Box 8003 Wausau, WI 54402-8003 Phone: 715-675-8237	Generator (PN: 0116-1120, VPN: 431PSL6309)	12 months from date of startup or 18 months from date of shipment whichever period shall expire first.
Signal Transformer 500 Bayview Avenue Inwood, NY 11096-1792 Phone: 516-239-5777	Transformer 1250 VA (PN: 0116-1257, VPN: HP1-12)	12 Months
Derema Group 46 Acorn Drive Westbrook, CT 06498 Phone 860-399-5669	Switch, Battery Disconnect (PN: 0116-1298, VPN: 2304-A)	12 Months

**100 kW TACTICAL QUIET GENERATOR SET
WARRANTY INFORMATION – Continued**

0023 00

MANUFACTURER WARRANTY INFORMATION – Continued

Table 1. Manufacturer's Warranties for 100 KW Generator Set – Continued.

(1) MANUFACTURER	(2) COMPONENT UNDER WARRANTY	(3) WARRANTY PERIOD
Contact Industries P.O. Box 3086 25 Lex-Industrial Drive Lexington, OH 44904 Phone: 419-884-9788	Contactor, Load (PN: 0116-1266, VPN: CT400E-24E4S)	12 Months
Madison Company 27 Business Park Drive Branford, CT 06405 Phone: 203-488-4477	Fuel Level Switch (PN: 0116-1304, VPN: M3862)	12 Months
Technology Research Co 5250 140 th Avenue North Clearwater, FL 33760 Phone: 727-535-0572 Rwood@TRCI.net	Relay, Overload/Short Circuit (PN: 0116-1219, VPN: 19970)	12 Months
G & O Manufacturing Co. 100 Gando Drive New Haven, CT 60513 Phone: 601-366-1423	Radiator Assembly (PN: 0116-1400, VPN: X6642-00-50)	18 months from shipment or 12 months in service
Parker Hannifin Corporation Racor Division Phone: 209-575-7651 hbrizuela@parker.com	Filter, Crankcase Ventilation (PN: 0116-1607-01, VPN: CCV4500-08L)	12 Months
Donaldson Company, Inc. Minneapolis, MN 55440-1299 Phone: 800-374-1374 www.donaldson-filters.com	Muffler, Exhaust (PN: 0116-1500, VPN: WOM12-0743) Air Cleaner Assembly (PN: 0116-1600, VPN: FTG-11-0103)	36 Months 12 Months

GLOSSARY

TERM	DEFINITION
Bus	The common power conducting wires or bars to which all power sources within the power system are connected through their individual circuit breakers.
Dead Bus	A bus from which all the available power sources are disconnected.
De-energize	To remove voltage from a circuit or device in order to deactivate it.
Droop	Paralleling mode that allows slight fluctuations in frequency so that lagging generator set can match frequency of companion generator.
EMI	Electromagnetic interference is any electromagnetic disturbance that interrupts, obstructs or other wise degrades or limits the effective performance of electronics and electrical equipment as a result of spurious emissions and responses.
Energize	To apply voltage to a circuit or device in order to activate it.
Excitation voltage	DC voltage applied from the voltage regulator to the generator exciter field windings.
Generator overload condition	Load greater than the load for which the system or mechanism was intended. For TQGs, overload is defined as the condition when current in all three phases exceeds 100% of rated current or when current in a single phase exceeds 130% of rated current.
Ground fault circuit interrupter (GFCI)	A device intended for the protection of personnel that functions to de-energize a circuit or portion thereof within an established period of time when a current to ground exceeds some predetermined value that is less than that required to operate the overcurrent protection device of the supply circuit. The TQG convenience receptacle is protected by a GFCI.
Incoming generator	The generator that is being connected to the bus.
Isochronous	Paralleling mode that requires precise matching of frequency for companion generators.
kV	Kilovolt. One kilovolt equals 1000 volts.
KVAR	Kilovolt amperes reactive. Measure of reactive power.
KVARhr	Kilovolt amperes reactive hours. Measure of reactive power over time.
kW	Kilowatt. One kilowatt equals 1000 watts. Measure of real power.
Load bus	Common power conducting wires or bars to which all generator set loads are connected through their individual circuit breakers.
Overcurrent condition	Any current in excess of the rated current of equipment. The condition may result from overload, short circuit, or ground fault.
Paralleling	The procedure for synchronizing and connecting two or more generator sets to a common load bus.
Reverse power	Power flows from one generator set into another generator set when operating in parallel. For the TQGs, reverse shutdown power occurs when reverse power exceeds 17% of rated value.

GLOSSARY – Continued

TERM	DEFINITION
TQG control circuit	Primarily consists of 24 VDC circuitry, meters and controls for generator set starting, stopping, monitory, and fault annunciation.
Wet stacking	Buildup of unburned diesel fuel and carbon residues in the engine and exhaust system of diesel engines. Wet stacking can cause an oily, tar-like residue to exit from the exhaust pipe.

INDEX

Subject **WP Sequence No.-Page No.**

-A-

Abbreviations/Acronyms, List of	0001 00-3
AC Generator	
Characteristics	0002 00-1
Description	0002 00-3
Additional Authorization List (AAL).....	0021 00-1
AAL Column Descriptions (Table 1).....	0021 00-1
Table 1. Additional Authorization List.....	0021 00-1
Air Cleaner Assembly	
Characteristics	0002 00-1
Description	0002 00-1
Alternator	
Characteristics	0002 00-1
Description	0002 00-1
Auxiliary Equipment, Operating	0006 00-37

-B-

Basic Issue Items List (BII).....	0020 00-1
BII List Descriptions (Table 2).....	0020 00-5
Table 2. Basic Issue Item List	0020 00-5
Batteries	
Characteristics	0002 00-1
Description	0002 00-4

-C-

Components of End Item (COEI).....	0020 00-1
COEI List Descriptions (Table 1).....	0020 00-2
Table 1. Components of End Item List.....	0020 00-2
Common Tools and Test Equipment	0004 00-1
Connecting Auxiliary Fuel Hose	0006 00-8
Consolidated Index of Army Publications and Blank Forms	0001 00-1
Control Box Assembly Maintenance.....	0013 00-1
Repair	0013 00-1
Replace Control Panel Lights On Electronic Modular Control Panel (EMCP)	0013 00-1
Reset GROUND FAULT CIRCUIT INTERRUPTER Circuit Breaker.....	0013 00-3
Controls and Indicators (See Description and Use of Operator Controls and Indicators)	

INDEX – Continued

Subject

WP Sequence No.-Page No.

-C- Continued

Control Panel Assembly (EMCP)	
PMCS, Operator	0012 00-8
After	0012 00-15
Before	0012 00-8
During	0012 00-13
Convenience Receptacle, Use of	0006 00-37
Convenience Receptacles	
Characteristics	0002 00-1
Description	0002 00-4
Cooling System	
PMCS, Operator	0012 00-6
After	0012 00-15
Before	0012 00-6
During	0012 00-12
Corrosion Prevention and Control (CPC).....	0001 00-2

-D-

Dead Crank Switch	
Characteristics	0002 00-1
Description	0002 00-4
Decals and Instruction Plates	
Front	0006 00-29
Left Side	0006 00-31
Rear	0006 00-34
Right Side	0006 00-24
Destruction of Army Materiel to Prevent Enemy Use.....	0001 00-2
Description and Use of Operator Controls and Indicators	
Alarm Module	0005 00-10
Table 3. Alarm Module Controls and Indicators.....	0005 00-10
Battery Disconnect Switch	0005 00-15
Table 8. Battery Disconnect Switch Controls.....	0005 00-15
Dead Crank Switch.....	0005 00-13
Table 6. Dead Crank Switch Control.....	0005 00-13
Digital Voltage Regulator.....	0005 00-11
Table 4. Digital Voltage Regulator Controls and Indicators	0005 00-11
Electronic Modular Control Panel.....	0005 00-1
Table 1. Tactical Quiet Generator Electronic Modular Control Panel Controls and Indicators	0005 00-1
Fuel-Fired Heater Control Panel (Issued to Selected Units Only).....	0005 00-18
Table 11. Fuel-Fired Heater Control Panel (Winterization Kit) Controls and Indicators	0005 00-18
Generator Set Control.....	0005 00-4
Table 2. Generator Set Control Controls and Indicators	0005 00-4

INDEX – Continued

Subject

WP Sequence No.-Page No.

-D- Continued

Description and Use of Operator Controls and Indicators - Continued

Output Load Terminal Board TB2	0005 00-17
Table 10. Output Load Terminal Board TB2 Connections	0005 00-17
Paralleling Receptacles Panel	0005 00-14
Table 7. Paralleling Receptacles Panel Controls and Indicators	0005 00-14
Reconnection Board TB1	0005 00-16
Table 9. Reconnection Board TB1	0005 00-16
Resistor Assembly A7	0005 00-12
Table 5. Resistor Assembly A7 Controls	0005 00-12

-E-

Electronic Modular Control Panel	
Characteristics	0002 00-1
Description	0002 00-4
Emergency Stopping.....	0006 00-14
Engine	
Characteristics	0002 00-1
Description	0002 00-1
Engine Air Cleaner Maintenance.....	0014 00-1
Inspection	0014 00-1
Service	0014 00-2
Engine Compartment	
PMCS, Operator	0012 00-5
After	0012 00-14
Before	0012 00-5
During	0012 00-10
Engine Control Module	
Characteristics	0002 00-1
Description	0002 00-7
Engine Cooling System Maintenance.....	0015 00-1
Inspection	0015 00-1
Service	0015 00-2
Engine Fuel System Maintenance.....	0016 00-1
Inspection	0016 00-2
Fuel Filter/Water Separator	0016 00-2
Fuel Tank.....	0016 00-2
Service	0016 00-3
Fuel Filter/Water Separator Service	0016 00-4
Fuel Tank Service.....	0016 00-3
Table 1. Diesel Fuel.....	0016 00-4

INDEX – Continued

Subject

WP Sequence No.-Page No.

-E- Continued

Engine Lubrication System Maintenance	0017 00-1
Inspection	0017 00-1
Service	0017 00-1
Table 1. Engine Oil.....	0017 00-2
Equipment Characteristics, Capabilities, and Features	0002 00-1
Equipment Data	0002 00-9
Table 1. 100 kW TQG Equipment Data	0002 00-9
Equipment Deficiency Reporting	0001 00-2
Equipment Description and Data.....	0002 00-1
Expendable and Durable Items List.....	0022 00-1
Expendable and Durable Items List Column Descriptions (Table 1).....	0022 00-1
Table 1. Expendable and Durable Items List.....	0022 00-2

-F-

Fuel-Fired Heater	
Characteristics	0003 00-8
Description	0002 00-4
Operation	0007 00-2
Fuel Tank	
Characteristics	0002 00-1
Description	0002 00-7

-G, H-

General Information	0001 00-1
Generator, AC (See AC Generator)	
Generator Housing Installation	
Characteristics	0002 00-1
Description	0002 00-8
Generator Set	
PMCS, Operator	0012 00-4
Before.....	0012 00-4
Glossary.....	Glossary-1
Ground Rod, Installation	0006 00-2

INDEX – Continued

Subject

WP Sequence No.-Page No.

-I, J, K-

Initial Adjustments Before Use and Self-Test	0006 00-9
Initial Adjustments	0006 00-9
Self-Test	0006 00-9
Inspections	
Coolant Level	0015 00-1
Engine Air Cleaner	0014 00-1
Fuel Filter/Water Separator	0016 00-2
Fuel Level	0016 00-2
Oil Level	0017 00-1

-L-

List of Abbreviations/Acronyms	0001 00-3
Load Board	
Characteristics	0002 00-1
Description	0002 00-3
Load Cables, Installation	0006 00-6
Table 1. Load Terminal and AC Reconnection Board	0006 00-7
Location and Description of Major Components	0002 00-1
AC Generator	0002 00-3
Air Cleaner Assembly	0002 00-1
Alternator	0002 00-1
Batteries	0002 00-4
Convenience Receptacles	0002 00-4
Dead Crank Switch	0002 00-4
Electronic Modular Control Panel	0002 00-4
Engine	0002 00-1
Engine Control Module	0002 00-7
Fuel Tank	0002 00-7
Generator Housing Installation	0002 00-8
Load Board	0002 00-3
Main Contactor	0002 00-3
Muffler	0002 00-1
NATO Slave Receptacle	0002 00-4
Paralleling Receptacles	0002 00-4
Radiator	0002 00-1
Reconnection Board	0002 00-3
Skid Base	0002 00-7
Starter	0002 00-3
Trailer-Mounted Configuration (PU-807A)	0002 00-8
Turbocharger	0002 00-1
Water Pump	0002 00-1
Winterization Kit (Issued to Selected Units Only)	0002 00-4

INDEX – Continued

Subject

WP Sequence No.-Page No.

-M-

Main Contactor	
Characteristics	0002 00-1
Description	0002 00-3
Maintenance Forms, Records, and Reports	0001 00-1
Malfunction/Symptom Index, Introduction	0008 00-1
Malfunction/Symptom Index	0009 00-1
Muffler	
Characteristics	0002 00-1
Description	0002 00-1

-N-

NATO Slave Receptacle	
Characteristics	0002 00-1
Description	0002 00-4
Nomenclature Cross-Reference List	0001 00-3

-O-

Operator Controls and Indicators (See Description and Use of Operator Controls and Indicators)	
Operating Procedures	0006 00-10
Starting	0006 00-11
Stopping Procedure	0006 00-14
Operation Under Usual Conditions	0006 00-1
Assembly and Preparation for Use	0006 00-1
Decals and Instruction Plates	0006 00-24
Emergency Stopping	0006 00-14
Initial Adjustments Before Use and Self-Test	0006 00-9
NATO Slave Receptacle Start Operation	0006 00-10
Operating Auxiliary Equipment	0006 00-37
Operating Procedures	0006 00-10
Parallel Unit Operation (Load Sharing)	0006 00-15
Preparation for Movement	0006 00-38
Shelter Requirements	0006 00-1
Siting Requirements	0006 00-1
Operation Under Unusual Conditions	0007 00-1
Operation at High Altitudes	0007 00-6
Operation in Extreme Cold Weather Below -25°F (-32°C)	0007 00-1
Operation in Extreme Heat Above 120°F (49°C)	0007 00-3
Operation in Dusty or Sandy Conditions	0007 00-4

-O- Continued

INDEX – Continued

Subject

WP Sequence No.-Page No.

Operation Under Unusual Conditions - Continued

Operation in Salt Water Areas.....	0007 00-5
Operation of Winterization Kit.....	0007 00-2
Operation Under Rainy or Humid Conditions.....	0007 00-5
Operation Using Battle Short Switch	0007 00-6
Operation While Contaminated (NBC)	0007 00-6

-P, Q-

Parallel Unit Operation (Load Sharing).....	0006 00-15
Operation in Auto Mode.....	0006 00-18
Operation in Permissive Mode	0006 00-21
Operation in Semi Auto Mode.....	0006 00-19
Pre-Operation	0006 00-15
Removal from Parallel Operation	0006 00-23

Paralleling Receptacles

Characteristics	0002 00-1
Description	0002 00-4

PMCS, Including Lubrication Instructions.....	0012 00-1
Fluid Leakage	0012 00-2
Introduction	0012 00-1
Inspection	0012 00-2
PMCS Column Descriptions (Table 1).....	0012 00-3
Table 1. Preventive Maintenance Checks and Services.	0012 00-4
After	0012 00-14
Before.....	0012 00-4
During	0012 00-12

Preliminary Checks and Adjustment of Equipment.....	0011 00-1
---	-----------

Preparation for Movement.....	0006 00-38
-------------------------------	------------

Preparation for Storage or Shipment	0018 00-1
Marking	0018 00-1
Packing	0018 00-1
Preservation	0018 00-1
Special Instructions for Administrative Storage.....	0018 00-1
Use of Corrosion-Preventive Compounds, Moisture Barriers, and Desiccant Materials	0018 00-1

-R-

Radiator

Characteristics	0002 00-1
Description	0002 00-1

INDEX – Continued

Subject

WP Sequence No.-Page No.

-R- Continued

Reconnection Board	
Characteristics	0002 00-1
Description	0002 00-3
References	0019 00-1
Commercial Manuals.....	0019 00-2
Department of Defense (DOD) Standards.....	0019 00-2
Field Manuals	0019 00-1
Forms.....	0019 00-1
Military Standards and Specifications.....	0019 00-2
Miscellaneous Publications	0019 00-1
Pamphlets	0019 00-2
Technical Bulletins.....	0019 00-2
Technical Manuals.....	0019 00-2
Removal from Parallel Operation	0006 00-23
Repair Parts.....	0004 00-1
Reporting Equipment Improvement Recommendations (EIR).....	0001 00-2

-S-

Safety, Care, and Handling	0001 00-5
Scope, General Information.....	0001 00-1
Self-Test.....	0006 00-9
Service	
Air Cleaner	0014 00-2
Cooling System	0015 00-2
Fuel Filter/Water Separator	0016 00-4
Fuel Tank.....	0016 00-3
Lubrication System.....	0017 00-1
Service Upon Receipt	0011 00-1
Preliminary Checks and Adjustment of Equipment	0011 00-1
Skid Base	
Characteristics	0002 00-1
Description	0002 00-7
Special Tools, TMDE, and Support Equipment	0004 00-1
Starter	
Characteristics	0002 00-1
Description	0002 00-3
Supporting Data for Repair Parts, Special Tools, TMDE, and Support Equipment.....	0004 00-1

INDEX – Continued

<u>Subject</u>	<u>WP Sequence No.-Page No.</u>
-T, U, V-	
Theory of Operation	0003 00-1
AC Power Output	0003 00-7
Air Intake and Exhaust System With Turbocharger	0003 00-6
Auxiliary Fuel Pump	0003 00-3
Engine Cooling System	0003 00-4
Engine Starting System	0003 00-1
Fuel System	0003 00-2
Fuel-Fired Heater System (Issued to Selected Units Only)	0003 00-8
Lubrication System	0003 00-5
Trailer Installation (PU-807A)	
PMCS, Operator	0012 00-9
Before	0002 00-9
Trailer-Mounted Configuration (PU-807A)	
Characteristics	0002 00-1
Description	0002 00-8
Troubleshooting	0010 00-1
Introduction	0008 00-2
Malfunction/Symptom Index	0009 00-1
Troubleshooting Procedures	0010 00-3
Table 1. Operator Troubleshooting	0010 00-3
Turbocharger	
Characteristics	0002 00-1
Description	0002 00-1
-W-	
Warranty Information (Also see WP 0001 00-3)	0023 00-1
Manufacturer Warranty Information	0023 00-1
Table 1. Manufacturer’s Warranties for 100 kW Generator Set	0023 00-2
Water Pump	
Characteristics	0002 00-1
Description	0002 00-1
Winterization Kit Operation	0007 00-2
Winterization Kit	
Characteristics	0002 00-1
Description	0002 00-4
Winterization Kit	
PMCS, Operator	0012 00-10
Before	0012 00-10

By Order of the Secretary of the Army:

Official:

SANDRA R. RILEY
*Administrative Assistant to the
Secretary of the Army*

0604502

PETER J. SCHOOMAKER
*General, United States Army
Chief of Staff*

By Order of the Secretary of the Air Force:

Official:

GEORGE T. BABBITT
*General, United States Air Force
Commander, AFMC*

JOHN P. JUMPER
*General, United States Air Force
Chief of Staff*

By Order of the Secretary of the Navy:

WALTER H. CANTRELL
*Rear Admiral, United States Navy
Commander, Space and Naval Warfare
Systems Command*

By Order of the Secretary of the Marine Corps:

RANDALL P. SHOCKEY
*Director, Program Support
Marine Corps Systems Command*

DISTRIBUTION:

To be distributed in accordance with the initial distribution number (IDN) 256886 requirements for TM 9-6115-729-10.



THEN ... JOT DOWN THE INFO ABOUT IT ON THIS FORM. CAREFULLY TEAR IT OUT. FOLD IT AND DROP IT IN THE MAIL.

SOMETHING WRONG WITH THIS PUBLICATION

FROM: (PRINT YOUR UNIT'S COMPLETE
Commander
Stateside Army Depot
ATTN: AMSTA-US
Stateside, N.J. 07703-5007

DATE SENT
10 July 1975

PUBLICATION TM 11-5840-340-12	PUBLICATION DATE 23 Jan 74	PUBLICATION Radar Set AN/PRC-
----------------------------------	-------------------------------	----------------------------------

BE EXACT PIN-POINT WHERE IT				IN THIS SPACE TELL WHAT IS WRONG AND WHAT SHOULD BE DONE ABOUT IT:
PAGE NO	PARA GRAPH	FIGURE NO	TABLE NO	
2-25	2-28			<p>Recommend that the installation antenna alignment procedure be changed throughout to specify a 20 IFF antenna lag rather than 10.</p> <p>REASON: Experience has shown that with only a 10 lag, the antenna servo system is too sensitive to wind gusting excess of 25 knots, and has a tendency to rapidly accelerate and decelerate as it hunts, causing strain to the drive train. Hunting is minimized by adjusting the lag to 20 degradation of operation.</p>
3-10	3-3		3-1	<p>Item 5, Functional column. Change 2 dB" to 3 dB .</p> <p>REASON: The adjustment procedure for the TRANS POWER FAULT indicator calls for a 3 dB (500 watts) adjustment to light the TRANS POWER FAULT indicator.</p>
5-6	5-8			<p>Add new step f.1 to read, "Replace cover plate removed in step e.1 above."</p> <p>REASON: To replace the cover plate.</p>
		FO-3		<p>Zone C 3. On J1-2, change +24 VDC" to +5 VDC".</p> <p>REASON: This is the output line of the 5 VDC power supply. +24 VDC is the input voltage.</p>

PRINTED NAME, GRADE OR TITLE AND TELEPHONE SSG I. M. DeSpirito 999-1776	SIGNATURE
--	---------------

FILL IN YOUR
UNIT'S ADDRESS

FOLD BACK

DEPARTMENT OF THE ARMY



OFFICIAL BUSINESS

PLEASE
AFFIX
STAMP
POSTAGE
REQUIRED

TEAR ALONG DOTTED LINE

Commander
U.S. Army Communications and Electronics Life Cycle Management Command
(C-E LCMC) and Fort Monmouth
ATTN: AMSEL-LC-LEO-E-ED
Fort Monmouth, New Jersey 07703-5006

RECOMMENDED CHANGES TO EQUIPMENT TECHNICAL PUBLICATIONS

SOMETHING WRONG WITH THIS PUBLICATION



THEN ... JOT DOWN THE INFO ABOUT IT ON THIS FORM. CAREFULLY TEAR IT OUT. FOLD IT AND DROP IT IN THE MAIL.

FROM: (PRINT YOUR UNIT'S COMPLETE ADDRESS)

DATE SENT

PUBLICATION NUMBER

PUBLICATION DATE

PUBLICATION TITLE

BE EXACT PIN-POINT WHERE IT IS

PAGE NO	PARA-GRAPH	FIGURE NO	TABLE NO
---------	------------	-----------	----------

IN THIS SPACE TELL WHAT IS WRONG AND WHAT SHOULD BE DONE ABOUT IT:

TEAR ALONG DOTTED LINE

PRINTED NAME, GRADE OR TITLE AND TELEPHONE NUMBER

SIGN HERE

FILL IN YOUR
UNIT'S ADDRESS

FOLD BACK

DEPARTMENT OF THE ARMY

OFFICIAL BUSINESS

PLEASE
AFFIX
STAMP
POSTAGE
REQUIRED

TEAR ALONG DOTTED LINE

Commander
U.S. Army Communications and Electronics Life Cycle Management Command
(C-E LCMC) and Fort Monmouth
ATTN: AMSEL-LC-LEO-E-ED
Fort Monmouth, New Jersey 07703-5006

RECOMMENDED CHANGES TO EQUIPMENT TECHNICAL PUBLICATIONS

SOMETHING WRONG WITH THIS PUBLICATION



THEN ... JOT DOWN THE INFO ABOUT IT ON THIS FORM. CAREFULLY TEAR IT OUT. FOLD IT AND DROP IT IN THE MAIL.

FROM: (PRINT YOUR UNIT'S COMPLETE ADDRESS)

DATE SENT

PUBLICATION NUMBER

PUBLICATION DATE

PUBLICATION TITLE

BE EXACT PIN-POINT WHERE IT IS

PAGE NO

PARA-GRAPH

FIGURE NO

TABLE NO

IN THIS SPACE TELL WHAT IS WRONG AND WHAT SHOULD BE DONE ABOUT IT:

TEAR ALONG DOTTED LINE

PRINTED NAME, GRADE OR TITLE AND TELEPHONE NUMBER

SIGN HERE

FILL IN YOUR
UNIT'S ADDRESS

FOLD BACK

DEPARTMENT OF THE ARMY

OFFICIAL BUSINESS

PLEASE
AFFIX
STAMP
POSTAGE
REQUIRED

TEAR ALONG DOTTED LINE

Commander
U.S. Army Communications and Electronics Life Cycle Management Command
(C-E LCMC) and Fort Monmouth
ATTN: AMSEL-LC-LEO-E-ED
Fort Monmouth, New Jersey 07703-5006

RECOMMENDED CHANGES TO EQUIPMENT TECHNICAL PUBLICATIONS

SOMETHING WRONG WITH THIS PUBLICATION



THEN ... JOT DOWN THE INFO ABOUT IT ON THIS FORM. CAREFULLY TEAR IT OUT. FOLD IT AND DROP IT IN THE MAIL.

FROM: (PRINT YOUR UNIT'S COMPLETE ADDRESS)

DATE SENT

PUBLICATION NUMBER

PUBLICATION DATE

PUBLICATION TITLE

BE EXACT PIN-POINT WHERE IT IS

PAGE NO	PARA-GRAPH	FIGURE NO	TABLE NO
---------	------------	-----------	----------

IN THIS SPACE TELL WHAT IS WRONG AND WHAT SHOULD BE DONE ABOUT IT:

TEAR ALONG DOTTED LINE

PRINTED NAME, GRADE OR TITLE AND TELEPHONE NUMBER

SIGN HERE

FILL IN YOUR
UNIT'S ADDRESS

FOLD BACK

DEPARTMENT OF THE ARMY



OFFICIAL BUSINESS

PLEASE
AFFIX
STAMP
POSTAGE
REQUIRED

TEAR ALONG DOTTED LINE

Commander
U.S. Army Communications and Electronics Life Cycle Management Command
(C-E LCMC) and Fort Monmouth
ATTN: AMSEL-LC-LEO-E-ED
Fort Monmouth, New Jersey 07703-5006

PIN: 083042-000